

CANON REPAIR MANUAL

CANON BOOSTER T FINDER
(REF. NO. 5-60091)

CANON INC. JAPAN

CANON GENERAL

CANON BOOSTER T FINDER
(REF. NO. 5-60091)

CANON INC. JAPAN

CANON BOOSTER T FINDER

1. GENERAL

The Canon Booster T Finder is an electronic, extremely sensitivity exposure meter-timer prism finder combination. It is designed especially for low-illumination measurements installed on the Canon F-1. It is capability of exposures up to 60 seconds. It incorporates automatic changeover of metering from the camera body to Booster T Finder when the illumination level falls below main meter minimums. It has a prism built in which replaces the eyelevel prism.

2. SPECIFICATIONS

2.1 Metering

1. Light sensitive elements: 2 CdS cells
2. Metering method: Stopped-down average metering Zero method
3. Metering range: Between 1/2 and 15 sec at ASA 100 FD 55mm F 1.2
4. Changeover of light measurement range: Automatic by turning the shutter speed dial, changeover from F-1 meter to Booster T Finder meter is effected.
5. Film speed: (ASA only) ASA 25 to 12800 scale with equal interval 25 .. 50 .. 100 .. etc.
6. Exposure time (Shutter timer scale) From 60 to 3 sec, the exposure time is by an electronic system slow timer with the shutter speed of the camer (F-1) set to B (bulb). Any shutter speed between 3 and 60 sec. is possible. The indicator lamp flashes 1 flash/sec. during long exposure. The shutter mechanism of the camera (F-1) functions normally between 1 and 1/60 sec.
7. Meter: High sensitivity pivot meter
8. Meter window: This Finder is provided with the meter window to allow exposure alignment from outside in the zero method system, and by turning on the main switch

- and closing the eyepiece shutter, the lamp comes on and illuminates the meter scale.
9. Lenses which permit metering: Because of stopped-down average metering, all Lenses (R, FL, and FD) are usable.
- 2.2 Finder: Same type as F1 Eyelevel finder.
 1. Eyelevel system with pentaprism: Equipped with Eye cup, Eyesight correction lens are available.
 2. Finder information: Only when the shutter speed is between 1/4 and 1/60 sec at ASA 100, the finder information appears illuminated at the right side of the finder.
 3. Finder magnification: 0.77 (FD 50mm F 1.4)
 4. Size of field: 97% of actual film face.
 - 2.3 Power supply: Normally, one silver oxide battery No. 544, 6V is used. For the external power supply, connection to the battery case is possible by 6V2B cord.
 1. Power switch: Provided
 2. Battery checker: Equipped. If the needle swings to the blue zone of the meter window at "C" of the power switch, it means that the battery is usable.
Over 4.8V
 - 2.4 Shutter release lock: Provided. Located at the side of shutter release button.
 - 2.5 Assembling of Eyepiece shutter: The eyepiece shutter is connected to the meter switch to prevent the meter from being affected by light entering through the finder, and the booster meter will not operate until the eyepiece shutter is closed.
 - 2.6 Installation on camera body: This Finder is installed sliding it on the pentaprism mounting position of the camera body, in the same

manner as the Eyelevel Finder. When the shutter speed dial is turned, the Finder mechanism interlocks with the camera. In this case, the shutter speed dial of the camera must be set between B and 1/30.

2.7 Override knob: The shutter speed dial of the finder will not turn beyond the 3 sec position unless the override knob is pushed to cut connection to the shutter dial of the camera.

- 2.8 Safety device:
1. Unless the Eyepiece shutter is closed, booster metering is impossible.
 2. Lighting of the illumination lamp in the finder can be observed from outside.
 3. Override knob

2.9 Dimensions: 72 long x 93.7 wide x 53mm high

Weight: 340g

3. Related parts

- 3.1 Case
- 3.2 Silver Oxide battery No. 544
- 3.3 Battery case
- 3.4 Finder dust cover
- 3.5 6V2B cord

3. EXPLANATION OF SPECIFICATIONS OF THIS FINDER

3.1 Timer mechanism

In the Canon Booster I, the shutter speed is set by locking the diaphragm release button of the camera, and zeroing the meter needle by setting the shutter scale. On the Booster T Finder, at shutter speeds between 3 and 60 sec, timed exposure are made automatically by means of the electronic timer built in the Finder. (The aperture can also be changed to zero the meter.)

3.2 Exposure meter mechanism

This Finder is provided with its own CdS and exposure meter mechanism independent of F-1 body, as shown in Fig. 5. The CdS are located at both sides of the Eyepiece Lens and this finder employs stopped-down metering system.

When the object brightness is within the metering range of the Booster, the contact switching lever is pushed by the ear of EV cam and the lamp contacts "b" and "c" are connected, lighting lamp 1.

Where F-1 exposure meter is in use, the contacts "a" and "b" are connected, lighting lamp 2.

3.3 Eyepiece shutter

Since the CdS meter of the Finder is near the Eyepiece Lens, it may be affected seriously by light entering through the finder.

Since the Booster T finder is designed to measure very low level illumination, any stray light would have a large effect on the meter reading; therefore the booster meter will not operate unless the Eyepiece shutter is closed, even if the main switch is on.

3.4 Count mechanism

When the film is being exposed, lamp 1 flickers at a rate of one Flicker every second. This, as illustrated in Fig. 1, makes the lamp flicker by the switching circuit through the multi-vibrator oscillation.

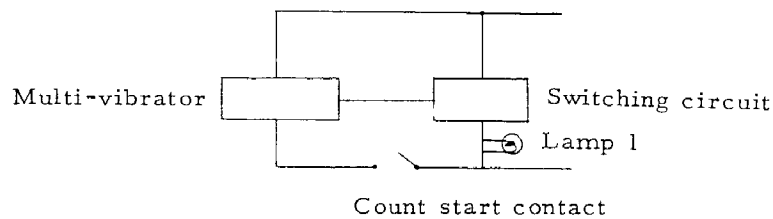

Fig. 1

3.5 Response speed

As the amount of light reaching a CdS decreases, the response time until the CdS reaches the correct reading increases. In other words, it takes a long time until the meter needle stabilizes and shows the correct exposure.

In the Booster I, it took much time since the CdS of FT body also served as that of the Booster but in Booster T Finder, the response speed has been doubled because of the use of photo-resistors made of both CdS and CdSe.

3.6 Power supply

1) EVEREADY NO. 544 Silver Oxide Battery 6V

As this battery is small and yet can supply the 6V required for booster operation, it can be incorporated into the booster. However, approx. 25mA is consumed by this Booster T Finder whereas the battery rated capacity is under 10mA. Therefore, it has a shorter life than the mercury battery used in the camera. Turn it off when not in use.

It is preferable to avoid using the battery at low temperature under 0° C.

Life of battery: 3 hours at 20° C (Continuous operation)
 2 hours at 5° C

When using this Finder for a long time or under low temperature, the external battery is usable. For using the external battery, take out No. 544 silver battery after detaching the battery cover of the Finder, connect one end of cord A with the connector "a" to the silver battery and the other end to the battery case. Then, Nicd or UM3 dry cell can be used. See Fig. 7.

3.7 Others

1. External indication of lamp lighting Fig. 8.

When the brightness of the object is within the metering range of the camera, the lamp which illuminates the meter indication window inside the Finder comes on, so the camera meter needles can be seen. So that there is always an external indication of which meter is in use, a small lamp window is provided at the left side of the booster. This lamp and

and the booster lamp also serve as a reminder that the main switch is on.

2. Usable accessories

- (1) Eye cup
- (2) Eyesight correction lenses
- (3) Magnifier
- (4) Angle finder
- (5) Battery case and Canon cord 6V2B

4. CAUTIONS FOR USE

- 4.1 When the shutter speed dial is set to any position between 3 and 60 sec, the shutter release button of Booster T Finder will lock down and hold the camera shutter button down even if the shutter is not charged, and counting will start. Therefore, it seems as if the shutter were released.

Also, when the camera is operated with the switch off, the shutter button will lock down and the shutter will open. This condition occurs automatically because of the timer mechanism and if the shutter speed dial is turned to 1 sec. the button is unlocked to return its original position.
- 4.2 Whenever installing this Booster on F-1, the shutter speed dial of the camera must be set to any position between B and 1/30.
- 4.3 Prior to installing the Booster, the film speed of the camera should be set.
- 4.4 Whenever metering within the metering range of the Booster, stop down Lens by operating the metering lever and then take reading. (Allow time for the meter to stabilize.)
- 4.5 For long exposures over 3 sec, release the connection between the shutter speed dial of the Booster and that of the camera by operating the override knob.
- 4.6 This Finder mechanism is so constructed that metering within the metering range of the Booster cannot be carried out unless the Eyepiece shutter is closed.

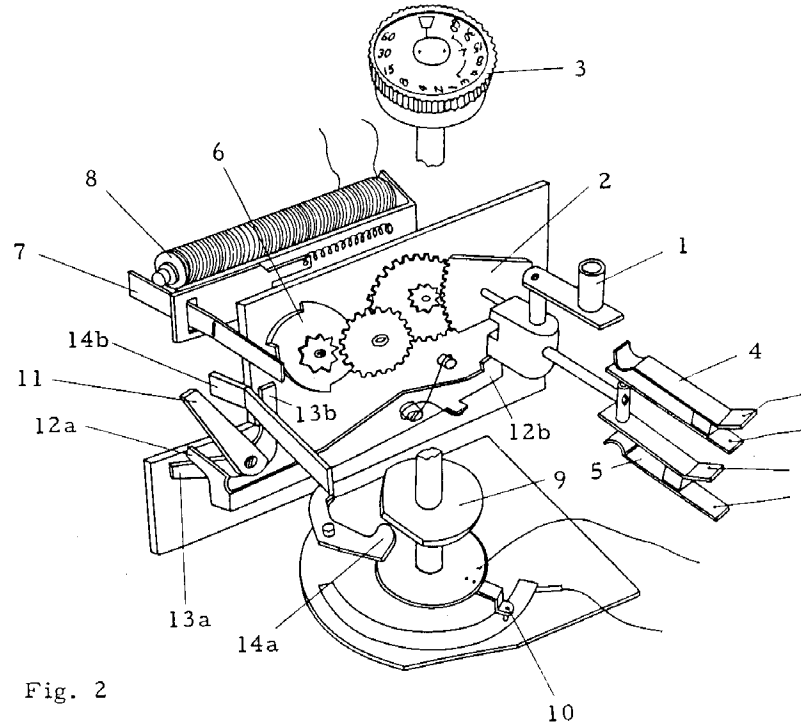

Fig. 2

- 1. Shutter release button 2. Gear A 3. Shutter Speed dial
- 4. Contact "a" (Charging of capacitor starts.)
- 5. Contact "b" (Timer counting starts) 6. Stopper 7. Lever E
- 8. Magnet 9. Cam 10. Timer contact 11. Lever A
- 12. Lever B 13. Lever C 14. Lever D

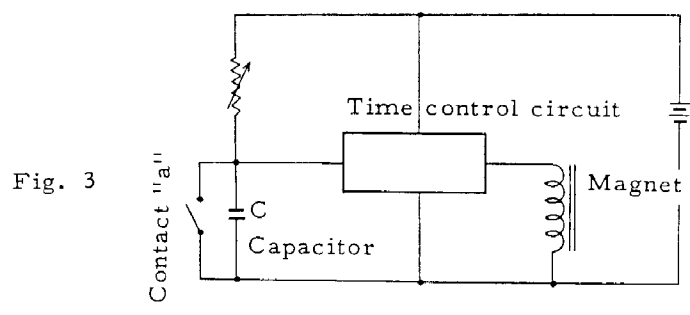

Fig. 3

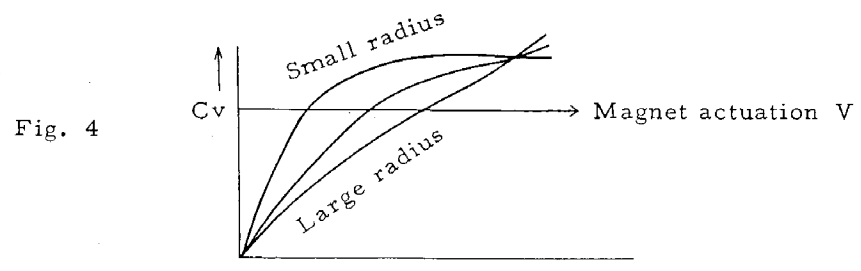

Fig. 4

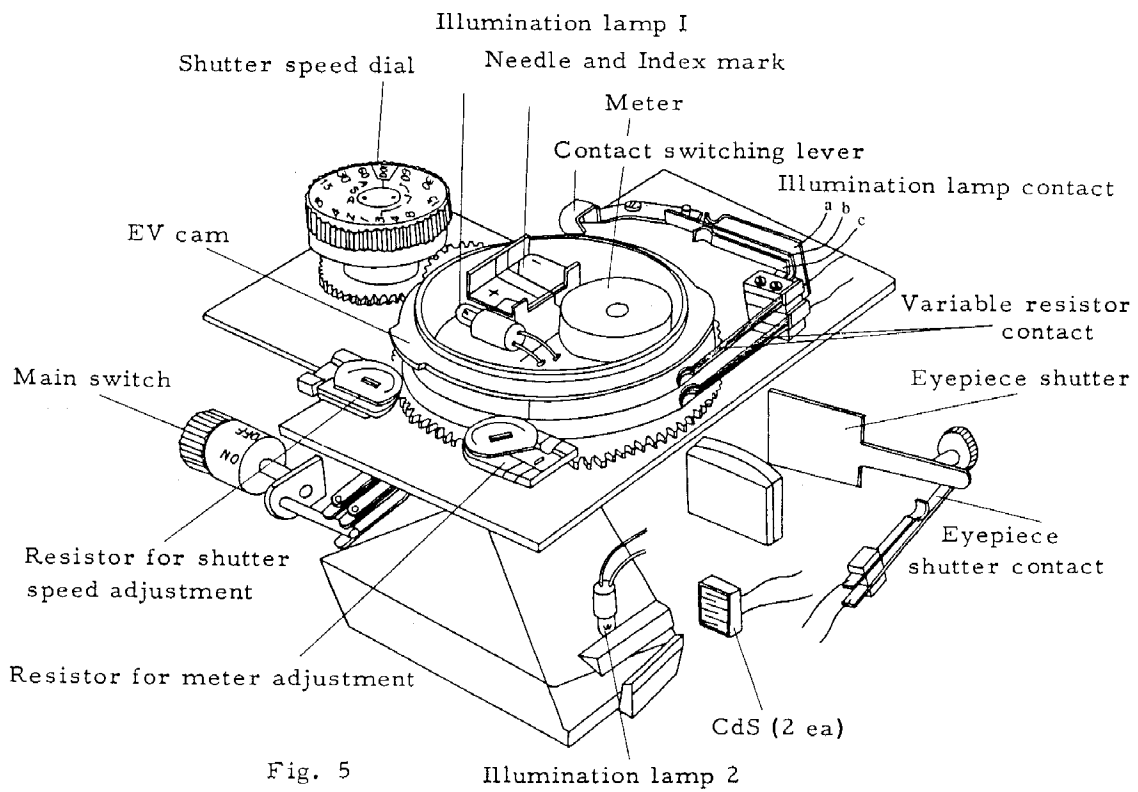

Fig. 5

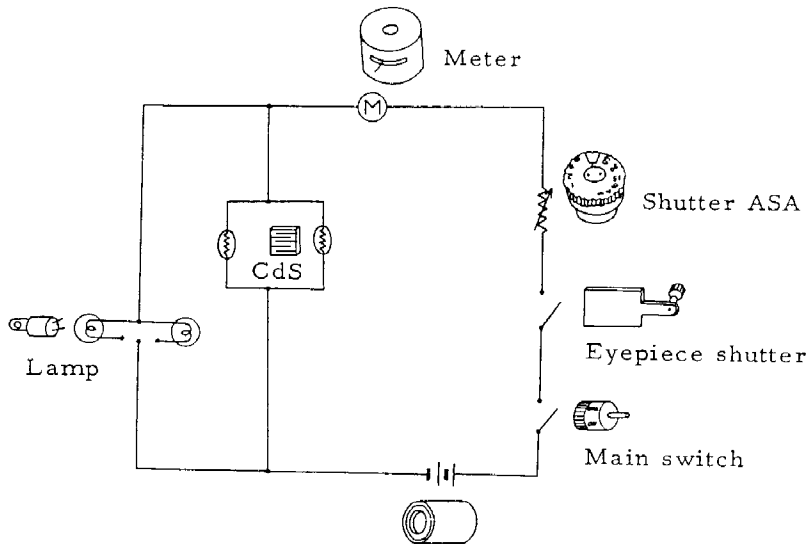

Fig. 6

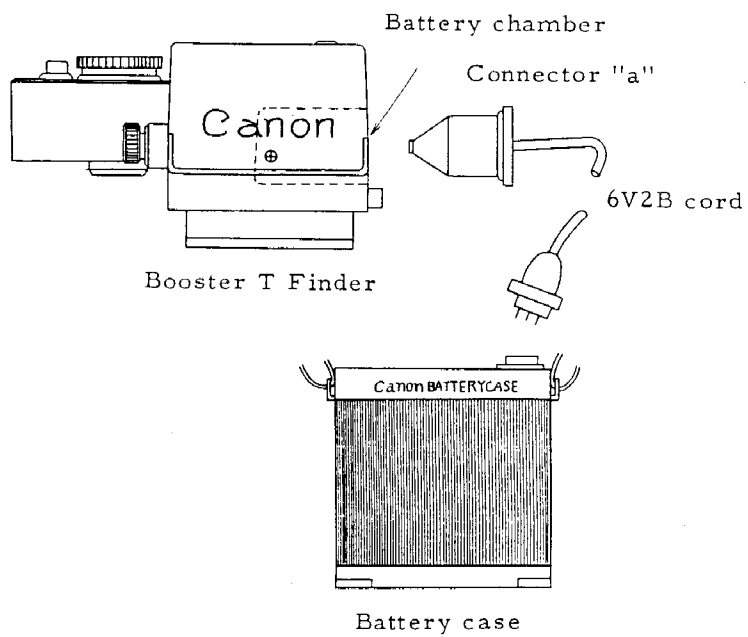

Fig. 7

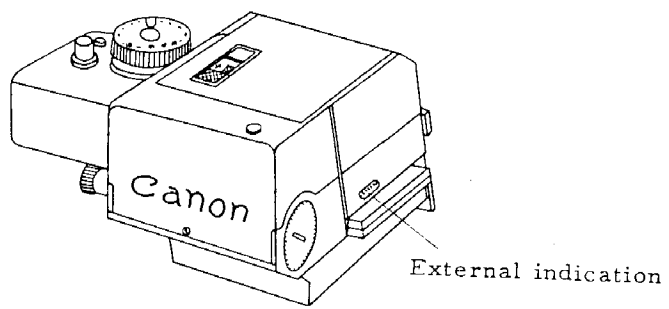

Fig. 8

CANON REPAIR MANUAL

CANON BOOSTER T FINDER
(REF. NO. 5-60091)

CANON INC. JAPAN

CONTENTS

	PAGE
SPEED DIAL スピードダイヤル	1
EYEPIECE アイピース	1
CdS UNIT CdSユニット	2
CONTACT 接片	2
PENTAPRISM ペンタプリズム	3
GOVERNOR UNIT ガバナーユニット	4
SHUTTER RELEASE シャッターレリーズ	4
ELECTRIC PARTS UNIT プリント板ユニット	5
WIRING DIAGRAM 回路図	6
SCHEMATIC DIAGRAM 配線図	7

EXPLODED VIEW
of
CANON BOOSTER T FINDER

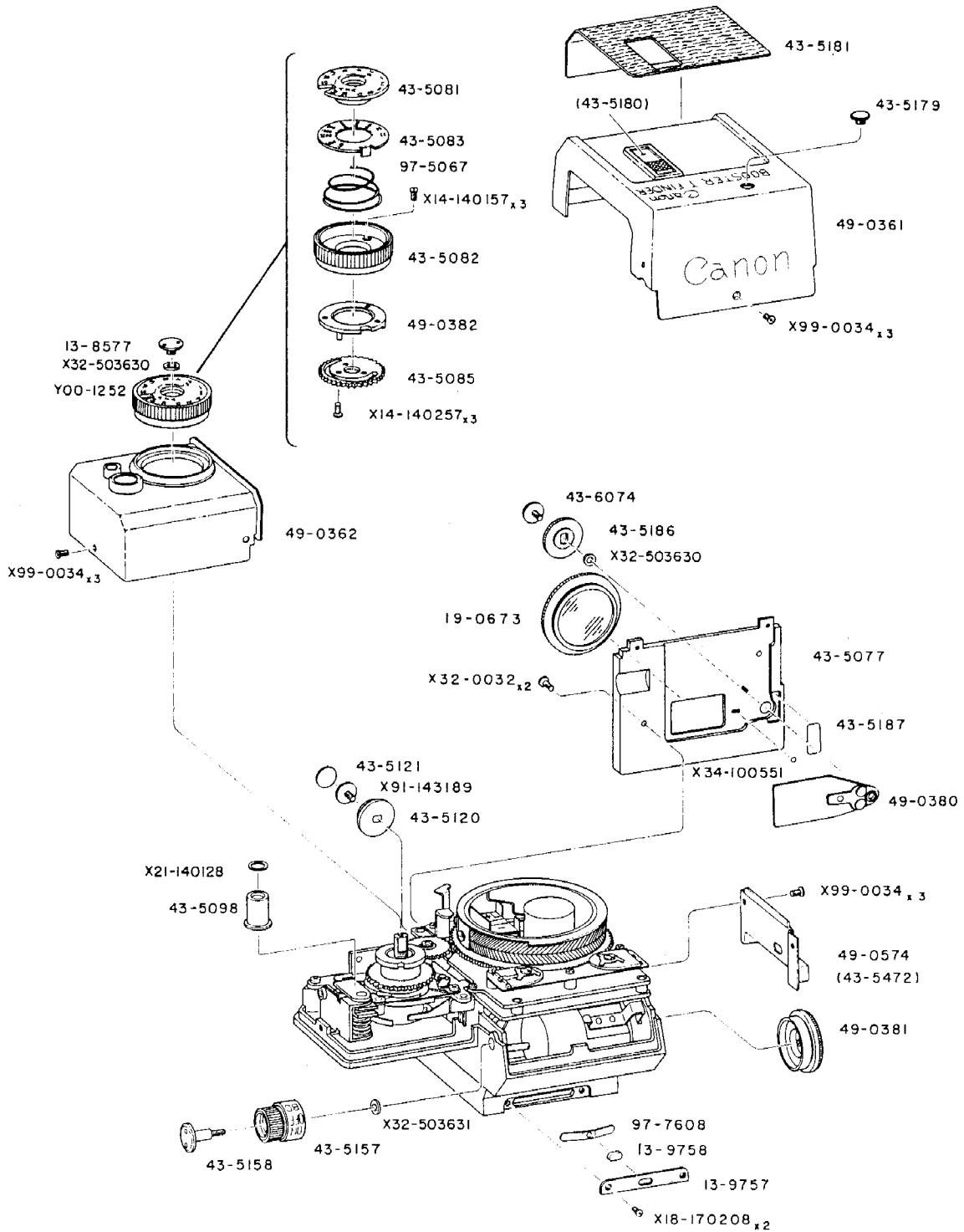

PARTS LIST

SPEED DIAL & EYEPIECE

スピード ダイヤル アイピース

部 品 名 称	CLASS	PARTS NO.	QTY.	DESCRIPTION
シャッタースピードダイヤル	C	Y00-1252	1	Shutter Speed Dial
カニメビス	C	13-8577	1	Pin Face Screw
マスク	D	13-9752	1	Mask
押え板	D	13-9757	1	Plate
セットピン	D	13-9758	1	Set Pin
視度調整レンズ	B	19-0673	1	Ocular
裏カバー	D	43-5077	1	Back Cover
シャッターダイヤル	C	43-5081	1	Shutter Speed Dial
シャッターつまみ	C	43-5082	1	Knurled Knob
ASAつまみ	D	43-5083	1	Film Speed Dial
感度割出し板	D	43-5085	1	Film Speed Setting Disk
シャッター	D	43-5098	1	Shutter Button
つまみ	D	43-5120	1	Knob
レザー	B	43-5121	1	Leather
メインスイッチつまみ	D	43-5157	1	Switch Knob
カニメビス	C	43-5158	1	Pin Face Screw
盲ぶた	C	43-5179	1	Cap
レザー	B	43-5181	1	Leather
メーター窓	D	43-5180	1	Meter Window
アイピースシャッターつまみ	D	43-5186	1	Eyeiece Knob
板	B	43-5187	1	Plate
ランプ窓	C	43-5472	1	Lamp Window
カニメビス	C	43-6074	1	Pin Face Screw
上部カバー	C	49-0361	1	Top Cover
横カバー	C	49-0362	1	Side Cover
アイピースシャッターバネ	C	49-0380	1	Aperture Leaf
バッテリーカバー	C	49-0381	1	Battery Cover
カップリング	D	49-0382	1	Coupling
横カバー	D	49-0574	1	Side Cover Left
コイルスプリング	D	97-5067	1	Coil Spring
板バネ	D	97-7608	1	Plate Spring
皿ビス		X14-140157	3	Screw
皿ビス		X14-140257	3	Screw
十字皿ビス		X18-170208	2	Screw
ワッシャー		X32-503630	N	Washer
		X32-503631		
スチールボール		X34-100551	1	Steel Ball
平ビス		X91-143189	1	Screw
ワッシャー		X98-060396	N	Washer
丸皿ビス		X99-0032	2	Screw
丸皿ビス		X99-0034	9	Screw

EXPLODED VIEW
of
CANON BOOSTER T FINDER

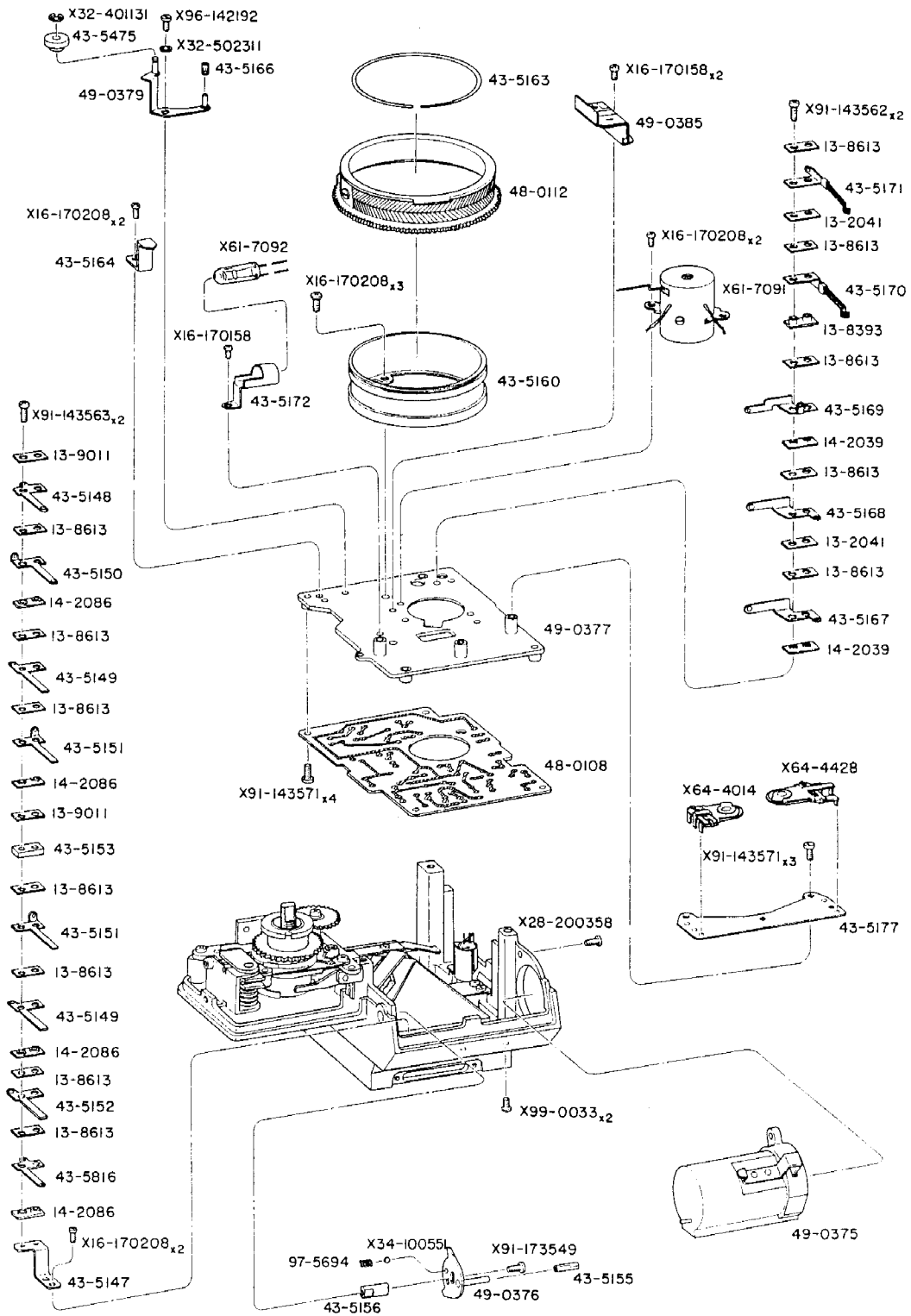

SCALE 1-2.0

© CANON INC.

PARTS LIST

CdS Unit & Contact

CdS ユニット 接片

部 品 名 称	CLASS	PARTS NO.	QTY.	DESCRIPTION
絶縁板	D	13-2041	4	Insulator
絶縁板	D	13-8393	4	Insulator
絶縁板	D	13-8613	12	Insulator
絶縁板	D	13-9011	2	Insulator
絶縁板	D	14-2039	1	Insulator
絶縁板	D	14-2086	2	Insulator
接片地	D	43-5147	1	Contact Base
接片	D	43-5148	1	Contact
接片	D	43-5149	1	Contact
接片	D	43-5150	1	Contact
接片	D	43-5151	1	Contact
接片	D	43-5152	1	Contact
ビニールチューブ	D	43-5153	1	Vinyl Tube
ビニールチューブ	D	43-5155	1	Vinyl Tube
スイッチつまみ軸	D	43-5156	1	Switch Knob Shaft
メータ室	D	43-5160	1	Meter House
割ワッシャー	D	43-5163	1	Snap Washer
カムストッパー	D	43-5164	1	Cam Stopper
ビニールチューブ	D	43-5166	1	Vinyl Tube
接片	D	43-5167	1	Contact
接片	D	43-5168	1	Contact
接片	D	43-5169	1	Contact
ブラシ	D	43-5170	1	Resistor Wiper
ブラシ	D	43-5171	1	Resistor Wiper
ランプホルダー	C	43-5172	1	Lamp Holder
プリント板	C	43-5177	1	Printed Circuit Board
カラ	D	43-5475	1	Collar
接片	D	43-5816	1	Contact
プリント板ユニット	C	48-0108	1	Electric Parts Unit
CdS ユニット	C	48-0112	1	CdS Unit
電池ボックス	C	49-0375	1	Battery Box
切換リング	D	49-0376	1	Switch Ring
中板	D	49-0377	1	Mechanism Plate
切換スイッチレバー	D	49-0379	1	Switch Lever
指標	D	49-0385	1	Index Plate
クリックバネ	D	97-5694	1	Click Spring
十字ナベビス		X16-170158	7	Screw
十字ナベビス		X16-170208	7	Screw
十字皿ビス		X28-200358	1	Screw
緊定ワッシャー		X32-401131		Retaining Washer
ワッシャー		X32-502311	N	Washer
ワッシャー		X32-503631	1	Washer
スチールボール	C	X35-100551	1	Steel Ball
メータ	C	X61-7091	1	Meter
ランプ	D	X61-7092	2	Lamp
抵抗	D	X64-4014	1	Resistor
抵抗	D	X64-4428	1	Resistor
平ビス	S	X91-143562	2	Screw
平ビス	S	X91-143571	3	Screw
平ビス	S	X91-173549	1	Screw
段ビス	S	X96-142192	1	Screw
丸皿ビス	S	X99-0033	2	Screw

EXPLODED VIEW
of
CANON BOOSTER T FINDER

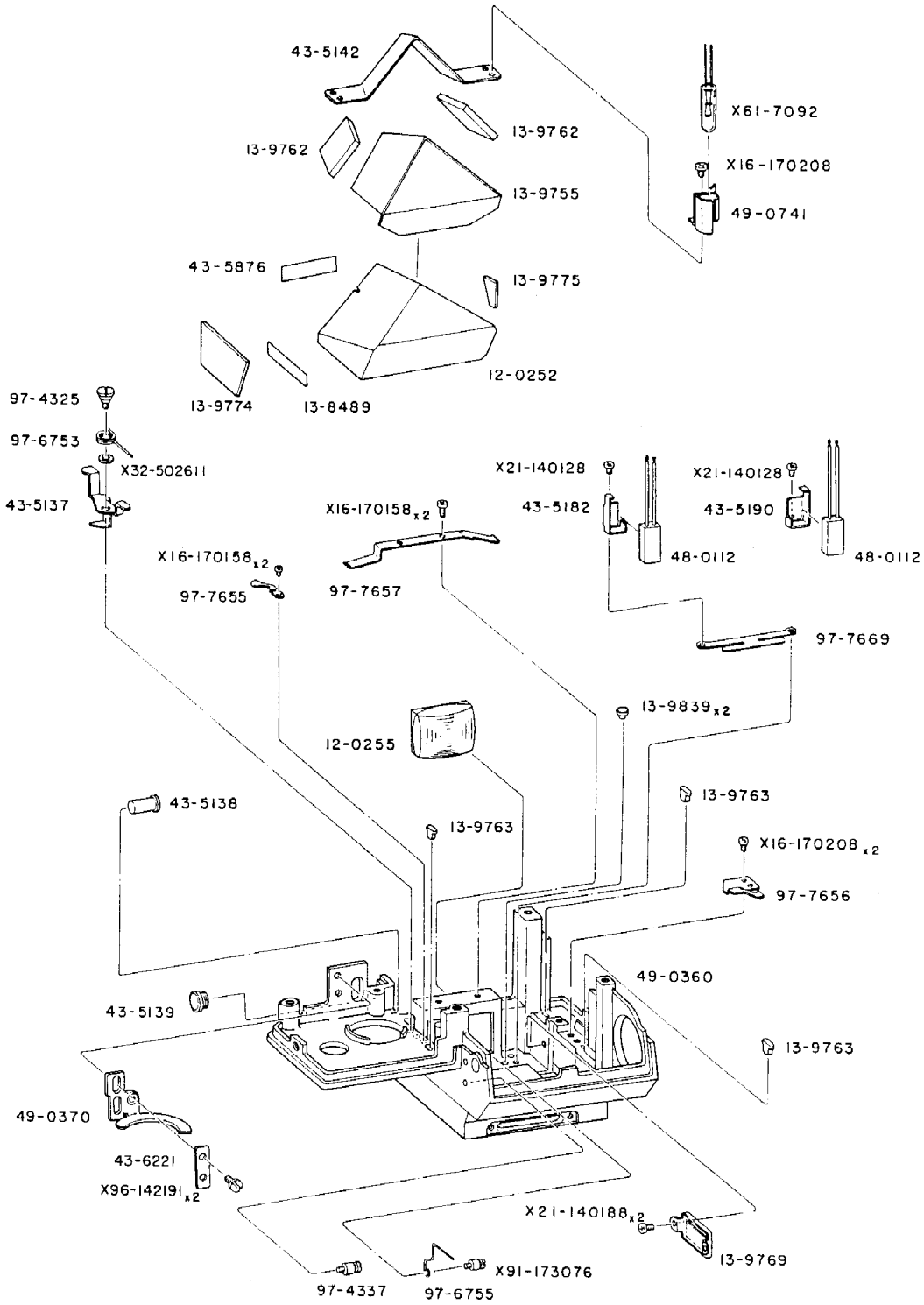

SCALE 1-2.0

© CANON INC.

PARTS LIST

PENTAPRISM

ペンタプリズム

部 品 名 称	CLASS	PARTS NO.	QTY.	DESCRIPTION
接 眼 レ ン ズ	C	12-0255	1	Eyepiece Lens
ス ベ ー サ ー	D	13-8489	N	Spacer
ブ リ ズ ム 押 え	D	13-9755	1	Pentaprism Support
遮 光 板	D	13-9762	2	Light Shield
ガ タ 止 め ビ ン	D	13-9763	4	Pin
マ ス ク	D	13-9769	1	Mask
ス ベ ー サ ー	D	13-9774	1	Spacer
ス ベ ー サ ー	D	13-9775	1	Spacer
コンデンサーレンズ押えピン	D	13-9839	2	Pin
ロ ッ ク 爪	D	43-5137	1	Lock Claw
ロ ッ ク 開 除 釦	D	43-5138	1	Lock Release Button
ロ ッ ク カ ラ ー	D	43-5139	1	Lock Release Collar
ペ ン タ 押 え	D	43-5142	1	Pentaprism Holder
C d S 取 付 台	B	43-5182	1	CdS Holder
C d S 取 付 台	B	43-5190	1	CdS Holder
ペ ン タ マ ス ク	D	43-5876	1	Pentaprism Mask
ワ ッ シ ャ ー	D	43-6221	1	Washer
C d S ユ ニ ッ ト	D	48-0112	1	CdS Unit
本 体	D	49-0360	1	Base Body
カップリング開除レバー	D	49-0370	1	Coupling Cancellation Lever
ラ ン プ ホ ル ダ ー	D	49-0741	1	Lamp Holder
ペ ン タ プ リ ズ ム	C	52-0252	1	Pentaprism
段 ビ ス	D	97-4325	1	Screw
スイッチレバーストッパー	D	97-4337	1	Switch Lever Stopper
バ ネ	D	97-6753	1	Spring
バ ネ	D	97-6755	1	Spring
板 バ ネ	D	97-7669	1	Plate Spring
板 バ ネ	D	97-7655	1	Plate Spring
板 バ ネ	D	97-7656	1	Plate Spring
板 バ ネ	D	97-7657	1	Plate Spring
十 字 ナ ベ ビ ス		X16-170158	2	Screw
十 字 ナ ベ ビ ス		X16-170208	3	Screw
平 ビ ス		X21-140128	2	Screw
平 ビ ス		X21-140188	2	Screw
ワ ッ シ ャ ー		X32-502611	2	Washer
ラ ン プ		X61-7092	1	Lamp
平 ビ ス		X91-173076	1	Screw
段 ビ ス		X96-142191	2	Screw

EXPLODED VIEW
of
CANON BOOSTER T FINDER

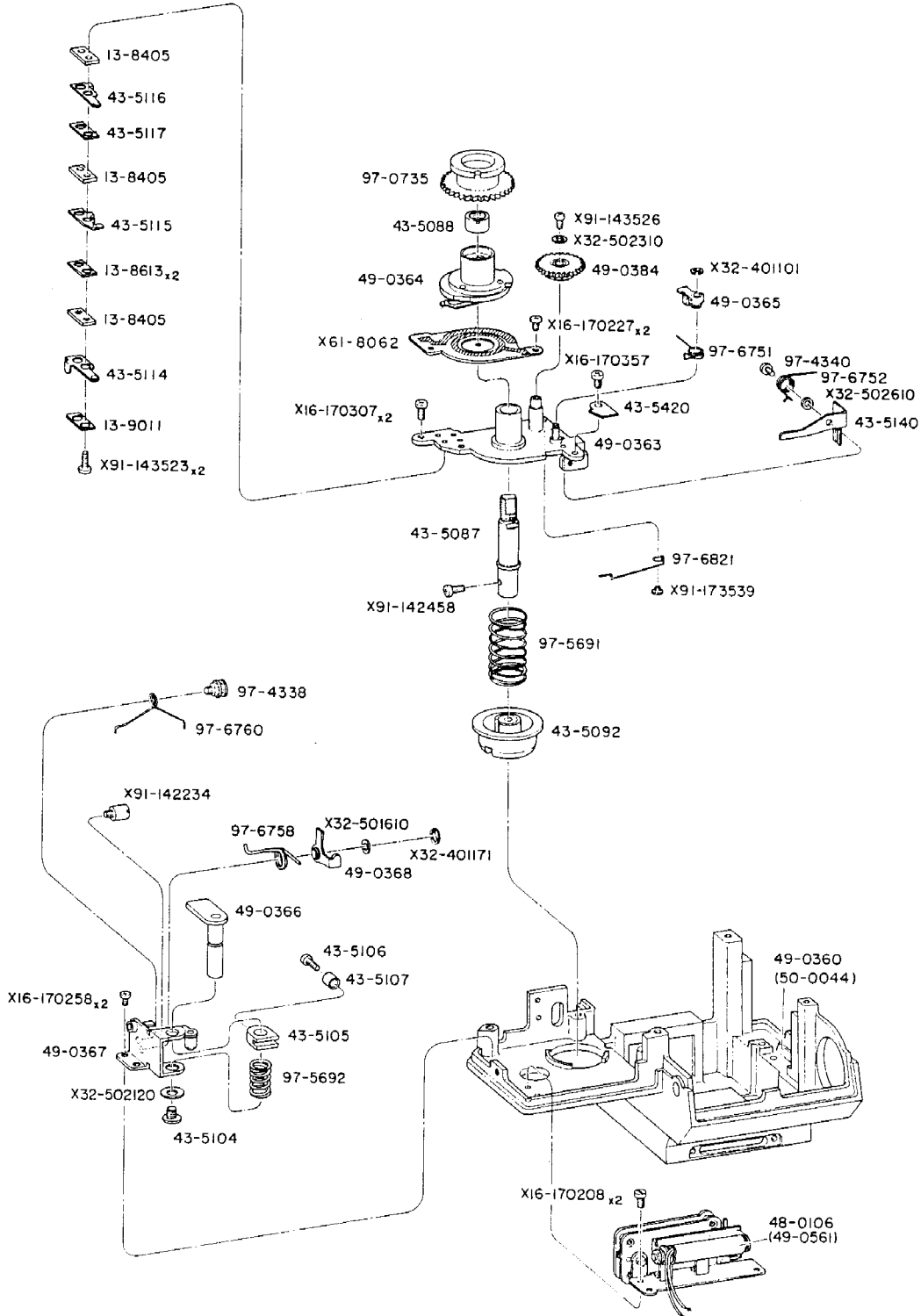

SCALE 1-2.0

© CANON INC.

PARTS LIST

GOVERNOR & SHUTTER RELEASE

カバナー シャッター レリーズ

部 品 名 称	CLASS	PARTS NO.	QTY.	DESCRIPTION
絶 縁 板	D	13-8405	4	Insulator
絶 縁 板	D	13-8613	13	Insulator
絶 縁 板	D	13-9011	1	Insulator
シャッターダイヤル軸	D	43-5087	1	Shutter Dial Shaft
カップリング	D	43-5088	1	Coupling
カップリング	D	43-5092	1	Coupling
レリーズ軸	D	43-5104	1	Release Shaft
スイッチコネクタ	D	43-5105	1	Switching Connector
ビス	D	43-5106	1	Screw
ビニールチューブ	D	43-5107	1	Vinyl Tube
ランプ接片	D	43-5114	1	Lamp Contact
接片	D	43-5115	1	Contact
接片	D	43-5116	1	Contact
絶 縁 板	D	43-5117	1	Insulator
ロック解除レバー	D	43-5140	1	Clutch Release Lever
ラグ	D	43-5420	1	Lug
ガバナーユニット	D	48-0106	1	Governor Unit
本体	D	49-0360	1	Base Body
シャッター構板	D	49-0363	1	Shutter Base Plate
シャッターダイヤルストッパー	D	49-0364	1	Shutter Dial Stopper
レリーズタイムレバー	D	49-0365	1	Release Time Lever
シャッターレリーズ軸	D	49-0366	1	Shutter Release Shaft
シャッターレリーズ受	D	49-0367	1	Shutter Release Holder
スイッチレバーストッパー	D	49-0368	1	Switch Lever Stopper
ギヤ	D	49-0384	1	Gear
マグネット	C	49-0561	1	Magnet
照明用プリズム	D	50-0044	1	Lamp Prism
ギヤ	D	97-0735	1	Gear
スイッチレバース	D	97-4338	2	Switch Lever Screw
ビス	D	97-4340	1	Screw
コイルスプリング	D	97-5691	1	Coil Spring
コイルスプリング	D	97-5692	1	Coil Spring
バネ	D	97-6751	1	Spring
バネ	D	97-6752	1	Spring
バネ	D	97-6758	1	Spring
バネ	D	97-6760	1	Spring
バネ	D	97-6821	1	Spring
十字ナベビス		X16-170208		Screw
十字ナベビス		X16-170227	2	Screw
十字ナベビス		X16-170258	5	Screw
十字ナベビス		X16-170357	1	Screw
緊定ワッシャー		X32-401101	1	Retaining Washer
緊定ワッシャー		X32-401171	2	Retaining Washer
ワッシャー		X32-501610	2	Washer
ワッシャー		X32-502120	N	Washer
ワッシャー		X32-502310	N	Washer
ワッシャー		X32-502610	N	Washer
プリント板		X61-8062	1	Printed Circuit Board
平ビス		X91-142234	1	Screw
平ビス		X91-142458	1	Screw
平ビス		X91-143523	2	Screw
平ビス		X91-143526	1	Screw
平ビス		X91-143564	4	Screw
平ビス		X91-173539	1	Screw

CANON BOOSTER T FINDER

ELECTRONICS PARTS UNIT

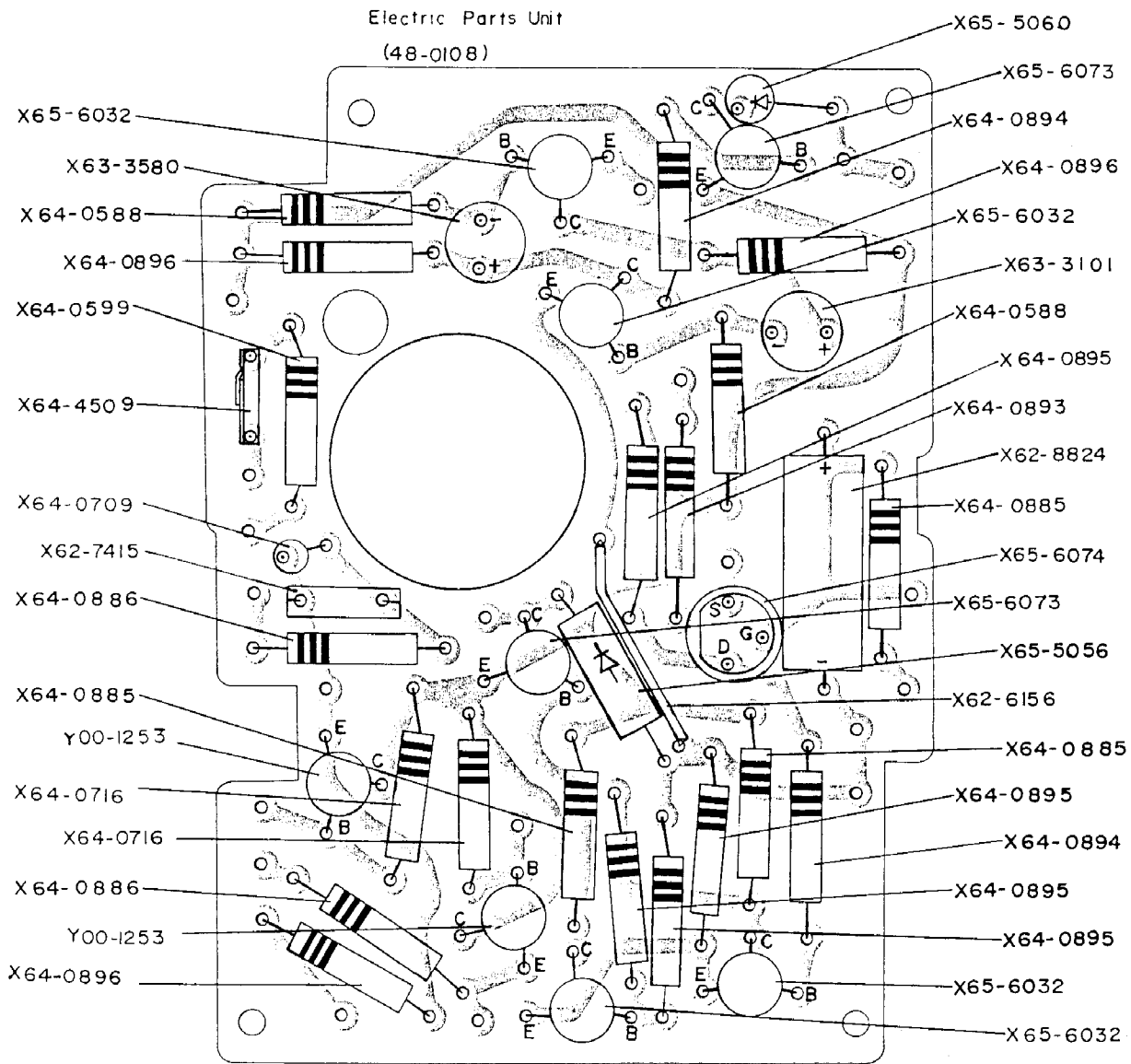

PARTS LIST

ELECTRONICS PARTS UNIT

電気部品ユニット

部 品 名 称	CLASS	PARTS NO.	QTY.	DESCRIPTION	REMARKS
トランジスタユニット	C	Y00-1253	2	Transistor Unit	2SC476
プリント板ユニット	D	48-0108	1	Electric Parts Unit	
プリント基板		X61-6952	1	Printed Circuit Board	
コンデンサ	D	X62-8824	1	Capacitor	
コンデンサ	D	X63-3101	1	Capacitor	
コンデンサ	D	X63-3580	1	Capacitor	
抵抗	抗	X64-0498	1	Resistor	33K Ω
抵抗	抗	X64-0588	2	Resistor	1K Ω
抵抗	抗	X64-0599	1	Resistor	330K Ω
抵抗	抗	X64-0716	1	Resistor	
抵抗	抗	X64-0885	3	Resistor	1K Ω
抵抗	抗	X64-0886	2	Resistor	4.7K Ω
抵抗	抗	X64-0893	1	Resistor	470 Ω
抵抗	抗	X64-0894	2	Resistor	2.2K Ω
抵抗	抗	X64-0895	3	Resistor	3.3K Ω
抵抗	抗	X64-0896	2	Resistor	6.8K Ω
抵抗	抗	X64-0897	1	Resistor	68K Ω
抵抗	抗	X64-4014	1	Resistor	1K Ω
抵抗	抗	X64-4428	1	Resistor	10K Ω
ダイオード	C	X65-5056	11	Diode	1S188
ダイオード	C	X65-5060	1	Diode	1S1212
トランジスタ	C	X65-6032	4	Transistor	2SC183
トランジスタ	C	X65-6073	2	Transistor	2SA542
トランジスタ	C	X65-6074	1	F. E. T. Transistor	2SK17

CANON BOOSTER T FINDER

WIRING DIAGRAM

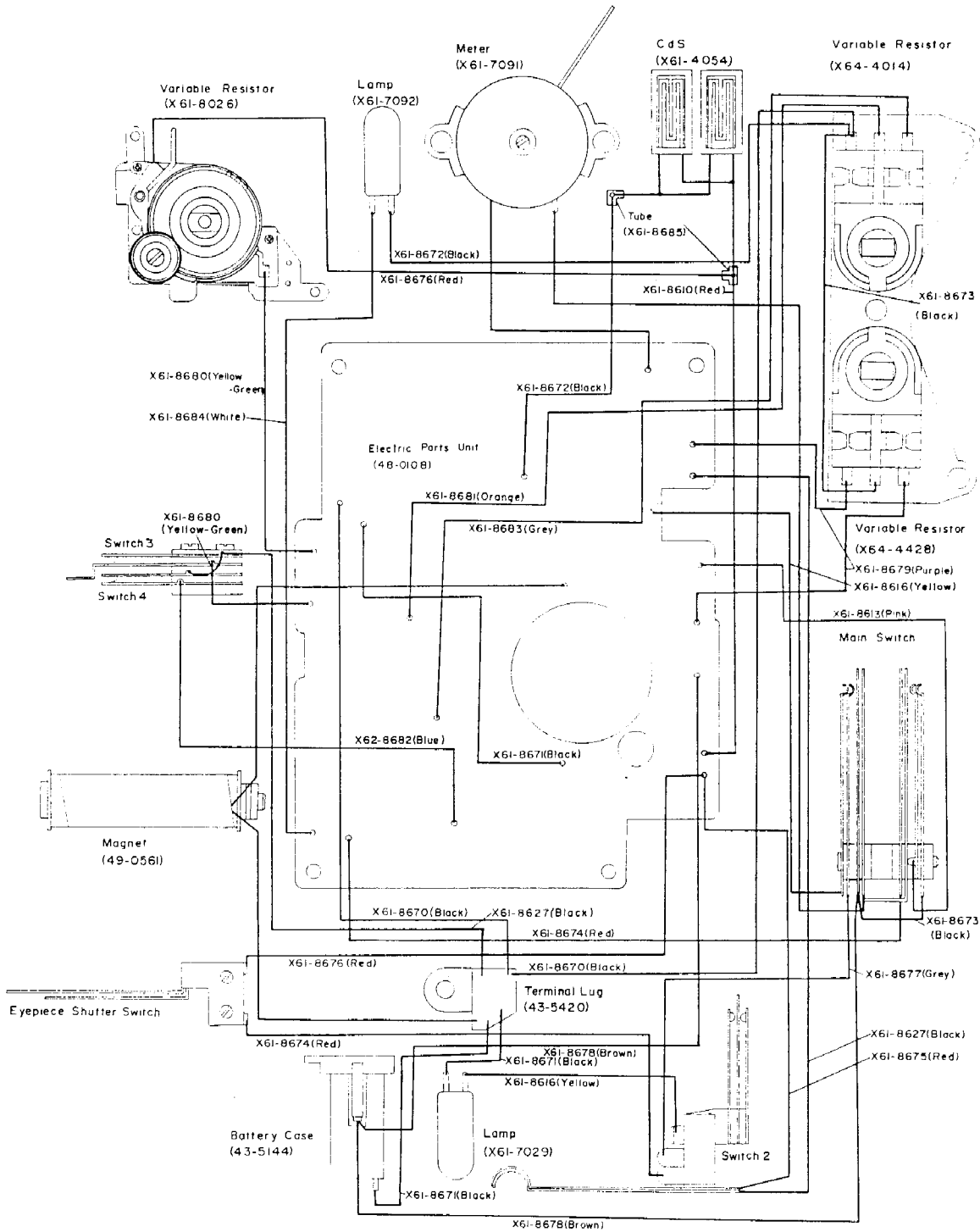

SCALE 1-2.0

© CANON INC.

PARTS LIST

WIRING DIAGRAM

配線図

部品名称	CLASS	PARTS NO.	QTY.	DESCRIPTION	REMARKS
リ - フ 線 (赤)	D	X61-8610	1	Lead (Red)	
リ - フ 線 (桃色)	D	X61-8613	1	Lead (Pink)	
リ - フ 線 (黄)	D	X61-8616	2	Lead (Yellow)	
リ - フ 線 (黒)	D	X61-8627	2	Lead (Black)	
リ - フ 線 (黒)	D	X61-8670	2	Lead (Black)	
リ - フ 線 (黒)	D	X61-8671	3	Lead (Black)	
リ - フ 線 (黒)	D	X61-8672	2	Lead (Black)	
リ - フ 線 (黒)	D	X61-8673	2	Lead (Black)	
リ - フ 線 (赤)	D	X61-8674	2	Lead (Red)	
リ - フ 線 (赤)	D	X61-8675	1	Lead (Red)	
リ - フ 線 (赤)	D	X61-8676	2	Lead (Red)	
リ - フ 線 (茶)	D	X61-8677	1	Lead (Brown)	
リ - フ 線 (茶)	D	X61-8678	2	Lead (Brown)	
リ - フ 線 (紫)	D	X61-8679	2	Lead (Purple)	
リ - フ 線 (黄緑)	D	X61-8680	2	Lead (Yellow Green)	
リ - フ 線 (橙)	D	X61-8681	1	Lead (Orange)	
リ - フ 線 (青)	D	X61-8682	1	Lead (Blue)	
リ - フ 線 (灰)	D	X61-8683	1	Lead (Grey)	
リ - フ 線 (白)	D	X61-8684	1	Lead (White)	
ビニールチューブ	D	X61-8685	2	Vinyl Tube	

CANON BOOSTER T FINDER

SCHEMATIC DIAGRAM

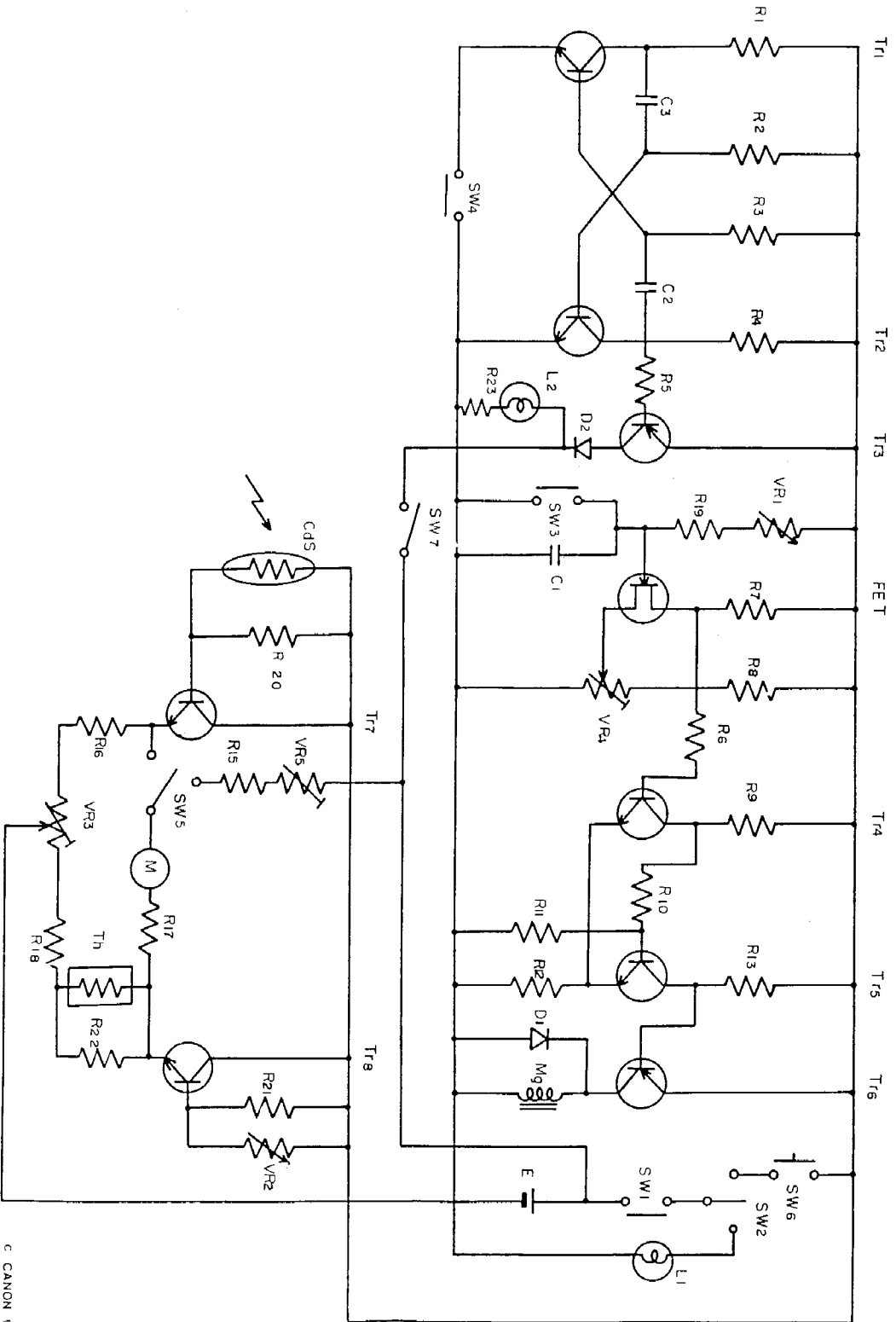

NO SCALE

© CANON INC

PARTS LIST

SCHEMATIC DIAGRAM

部 品 名 称	CLASS	SYMBOL	PARTS NO.	QTY.	DESCRIPTION	REMARKS
トランジスタユニット	C		Y00-1253	2	Transistor Unit	2SC476
メインスイッチ		SW ₁			Main Switch	
カメラファースタースイッチ		SW ₂			Meter Changeover Switch	
カウント開始スイッチ		SW ₃			Count Switch	
ランプスイッチ		SW ₄			Lamp Flashing Switch	
チェッカースイッチ		SW ₅			Battery Checker Switch	
アイピースシャッタースイッチ		SW ₆			Eyepiece Shutter Switch	
チェッカーランプスイッチ		SW ₇			Checker Lamp Switch	
マグネット		Mg		1	Magnet	0.08 x 4000t
Cd	S	CdS		2	CdS Cell	Rflux 15KΩ
メータ		M		1	Meter	
電池		E		1	Battery	No.544 (6V)
ランプ		L ₁		1	Lamp	6V 10mA
ランプ		L ₂		2	Lamp	6V 10mA
サーミスタ		Th		1	Thermistor	35D 26
プリント板ユニット	D		48-0108	1	Electric Parts Unit	
プリント基板	D		X61-6952	1	Printed Circuit Board	
コンデンサ	D	C1	X62-8824	1	Capacitor	SCR68PF
コンデンサ	D	C2	X63-3101	1	Capacitor	6.3V 1μ
コンデンサ	D	C3	X63-3580	1	Capacitor	6.3V 10μ
抵抗	D	R11	X64-0498	1	Resistor	33KΩ
抵抗	D	R2	X64-0588	1	Resistor	100KΩ
抵抗	D	R3	X64-0588	2	Resistor	100KΩ
抵抗	D	R15	X64-0599	1	Resistor	330KΩ
抵抗	D	R20	X64-0716	1	Resistor	1MΩ
抵抗	D	R21	X64-0716	1	Resistor	1MΩ
抵抗	D	R9	X64-0885	1	Resistor	1KΩ
抵抗	D	R13	X64-0885	1	Resistor	1KΩ
抵抗	D	R16	X64-0886	1	Resistor	4.7KΩ
抵抗	D	R8	X64-0893	1	Resistor	470Ω
抵抗	D	R5	X64-0894	1	Resistor	2.2KΩ
抵抗	D	R6	X64-0894	1	Resistor	2.2KΩ
抵抗	D	R7	X64-0895	1	Resistor	3.3KΩ
抵抗	D	R10	X64-0895	1	Resistor	3.3KΩ
抵抗	D	R12	X64-0895	1	Resistor	3.3KΩ
抵抗	D	R1	X64-0896	1	Resistor	6.8KΩ
抵抗	D	R4	X64-0896	1	Resistor	6.8KΩ
抵抗	D	RV4	X64-4014	1	Resistor	1KΩ
抵抗	D	RV3	X64-4428	1	Resistor	10KΩ
ダイオード	C	D1	X65-5056	1	Diode	1S188
ダイオード	C	D2	X65-5060	1	Diode	1S1212
トランジスタ	C	Tr1	X65-6032	1	Transistor	2SC183
トランジスタ	C	Tr2	X65-6032	1	Transistor	2SC183
トランジスタ	C	Tr4	X65-6032	1	Transistor	2SC183
トランジスタ	C	Tr5	X65-6032	1	Transistor	2SC183
トランジスタ	C	Tr3	X65-6073	1	Transistor	2SA542
トランジスタ	C	Tr6	X65-6073	1	Transistor	2SA542
トランジスタ	C	F.E.T.	X65-6074	1	F.E.T. Transistor	2SK17

INDEX OF PARTS NUMBERS

PARTS NO.	PAGE	PARTS NO.	PAGE	PARTS NO.	PAGE	PARTS NO.	PAGE
Y00-1252	1	43-5139	3	49-0365	4	X16-170258	4
Y00-1253	5	43-5140	4	49-0366	4	X16-170307	4
		43-5142	3	49-0367	4	X16-170357	4
12-0252	3	43-5147	2	49-0368	4		
12-0255	3	43-5148	2	49-0370	3	X18-170208	1
		43-5149	2	49-0375	2		
13-2041	2	43-5150	2	49-0376	2	X19-143571	2
13-8095	2	43-5151	2	49-0377	2		
13-8393	4	43-5152	2	49-0379	2	X21-140128	3
13-8405	4	43-5153	2	49-0380	1	X21-140188	3
13-8489	3	43-5155	2	49-0381	1		
13-8577	1	43-5156	2	49-0382	1	X28-200358	2
13-8613	2, 4	43-5157	1	49-0384	4		
13-9011	2, 4	43-5158	1	49-0385	2	X32-401101	4
13-9755	3	43-5160	2	49-0561	4	X32-401131	2
13-9757	1	43-5163	2	49-0574	1	X32-401171	4
13-9762	3	43-5164	2	49-0741	3	X32-501610	4
13-9763	3	43-5166	2			X32-502311	1
13-9769	3	43-5167	2	97-0735	4	X32-502310	4
13-9774	3	43-5168	2	97-4325	3	X32-502611	3
13-9775	3	43-5169	2	97-4337	3	X32-503630	2
13-9778	1	43-5170	2	97-4338	4	X32-502120	4
13-9839	2	43-5171	2	97-4340	4	X32-503631	2
		43-5172	2	97-5691	4		
14-2039	2	43-5177	2	97-5692	4	X34-100551	12
14-2086	2	43-5179	1	97-5694	2		
		43-5180	1	97-6751	4	X61-4110	7
19-0673	1	43-5181	1	97-6752	4	X61-6952	5
		43-5182	3	97-6753	3	X61-7091	2
43-5077	1	43-5186	1	97-6755	3	X61-7092	23
43-5081	1	43-5187	1	97-6756	3	X61-8026	4
43-5082	1	43-5190	3	97-6757	3	X61-8062	4
43-5083	1	43-5420	2	97-6758	4	X61-8610	5
43-5085	1	43-5472	1	97-6760	4	X61-8613	5
43-5087	4	43-5475	2	97-6821	4	X61-8616	5
43-5088	4	43-5816	2	97-7608	1	X61-8627	6
43-5092	4	43-5876	3	97-7609	3	X61-8670	5
43-5098	1	43-6074	1	97-7655	3	X61-8671	5
43-5104	4	43-6221	3	97-7656	3	X61-8672	5
43-5105	4			97-7657	3	X61-8673	5
43-5106	4	48-0106	4	97-7669	3	X61-8674	5
43-5107	4	48-0108	2			X61-8675	5
43-5114	4	48-0112	2, 3	X14-140157	1	X61-8676	5
43-5115	4			X14-140257	2	X61-8677	5
43-5116	4	49-0360	3, 4			X61-8678	5
43-5120	1	49-0361	1	X16-143563	2	X61-8679	5
43-5121	1	49-0362	1	X16-170158	2, 3	X61-8680	5
43-5137	3	49-0363	4	X16-170208	2, 3, 4	X61-8681	5
43-5138	3	49-0364	4	X16-170227	4	X61-8682	5

PARTS NO.	PAGE	PARTS NO.	PAGE	PARTS NO.	PAGE	PARTS NO.	PAGE
X61-8683	5	X99-0032	1				
X61-8684	5	X99-0033	2				
X61-8685	5	X99-0034	1				
X62-4110	5						
X62-6598							
X62-8824	6						
X63-3101	6						
X63-3580	6						
X64-0498	6						
X64-0588	6						
X64-0599	6						
X64-0716	6						
X64-0885	6						
X64-0886	5						
X64-0893	6						
X64-0894	6						
X64-0985	6						
X64-0986	6						
X64-0987	6						
X64-4014	6						
X64-4428	6						
X65-5056	6						
X65-5060							
X65-6032	6						
X65-6072	6						
X65-6073	6						
X65-6074	6						
X91-142234	4						
X91-142458	4						
X91-143571							
X91-143189	1						
X91-143523	4						
X91-143562	2						
X91-143563	2						
X91-143564	4						
X91-143526	4						
X91-173076	3						
X91-173549	2						
X91-173539	4						
X96-142191	3						
X96-142192	2						
X98-060396	1						

CANON REPAIR GUIDE

CANON BOOSTER T FINDER
(REF. NO. 5-60091)

CANON INC. JAPAN

CONTENTS

	Page
General	1
1. Disassembly	2
1.1 External Parts	2
1.2 Printed Circuit Board	3
1.3 Optical Parts	4
1.3.1 Disassembly	4
1.3.2 Assembly	5
2. Adjustment	6
2.1 Lock Claw	6
2.2 Mounting Position of Clutch	6
2.3 Variable Resistor and Shutter Speed Dial Position	6
2.4 Regular Position of Shutter Release Button	7
2.5 Locking Position of Shutter Release Button	7
2.6 Count Switch and Lamp Flashing Switch	8
2.7 Release Sequence	8
3. Replacement and Adjustment of CdS and Variable Resistor	8
3.1 Removal of CdS and Variable Resistor (Omitted)	8
3.2 Assembly	8
3.3 Adjustment of Meter Accuracy	9
3.4 Adjustment Timer	10
3.5 Adjustment of Checker	11
3.6 Lamp Selector Switch	11
4. Troubleshooting Chart	12

GENERAL

The Canon Booster T Finder when installed on the Canon F-1 measures the light and controls exposure time at low illumination levels (ASA 100 EV -3 to EV +2.)
The light measuring mode: Stopped-down averaging system.

With the Booster T finder mounted, shutter speeds from 1/60sec to several seconds (60 sec., ASA 25) are usable. The camera automatically chooses the correct meter (Booster T or Camera) for the chosen shutter speed.

The gamma and characteristics of the CdS cells and Variable Resistor (VR 2) are strictly selected and form a matched set. Therefore, they must be replaced as a set.

Meter Accuracy

The accuracy of the Booster T Finder is measured by setting a certain brightness on the light source and with FD Lens 50 mm 1:1.4 and 1% transmission filter and the subject Booster T mounted on an F1 body. Due to the extreme sensitivity of the Booster T finder, it must be tested in a dark room.

The Booster meter will not function unless the eyepiece shutter is closed.

The Pentaprism can be replaced without disturbing the electrical parts.

1. Disassembly

1.1 External Parts

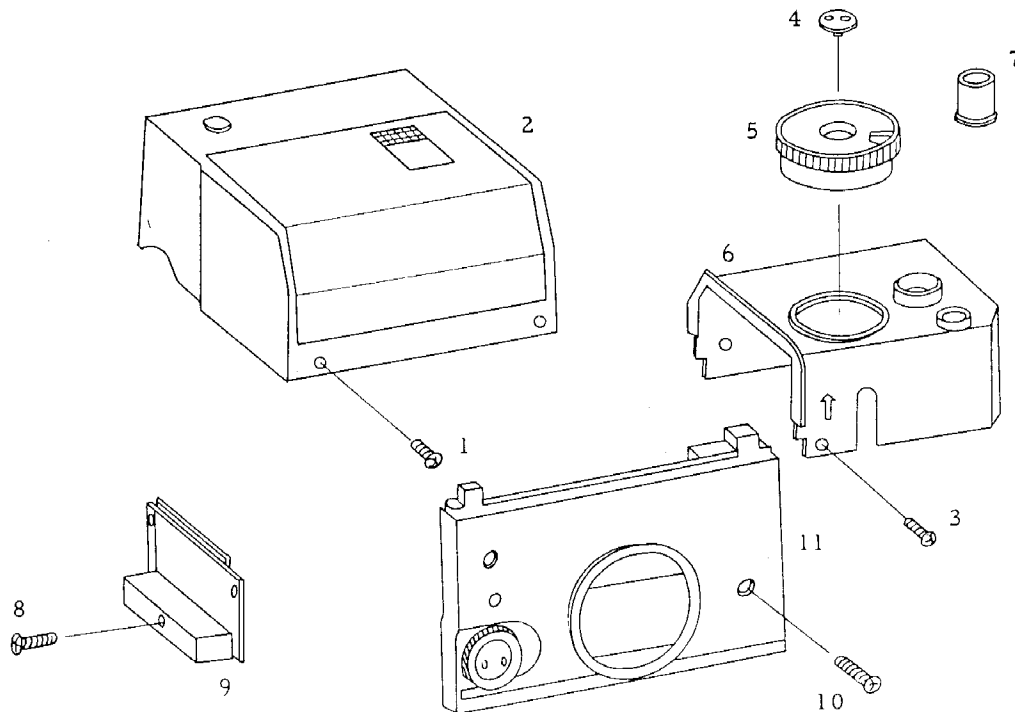

Remove each part in the following sequence.

Removal of Top Cover (2)

(1) Screw
99-0034 x 3

(2) Top Cover
49-0361

Removal of Side
Cover Right (6)

(3) Screw
X99-0034 x 3

(4) Pin Face Screw
13-9489

(5) Shutter Speed Dial
Y00-1252

(6) Side Cover Right
49-0362

(7) Shutter Button
43-5098

Removal of Side
Cover Left (9)

(8) Screw
X99-0034 x 3

(9) Side Cover Left
49-0547

Removal of Back
Cover (11)

(10) Screw

(11) Back Cover
43-5077

1.2 Printed Circuit Board

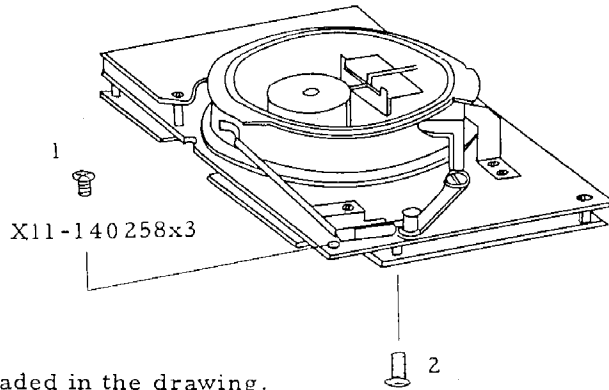

1. Remove the leads that are shaded in the drawing.

(Note) Some connections are covered by vinyl sleeving but it is omitted from the drawing for clarity. Remove the earth lead also.

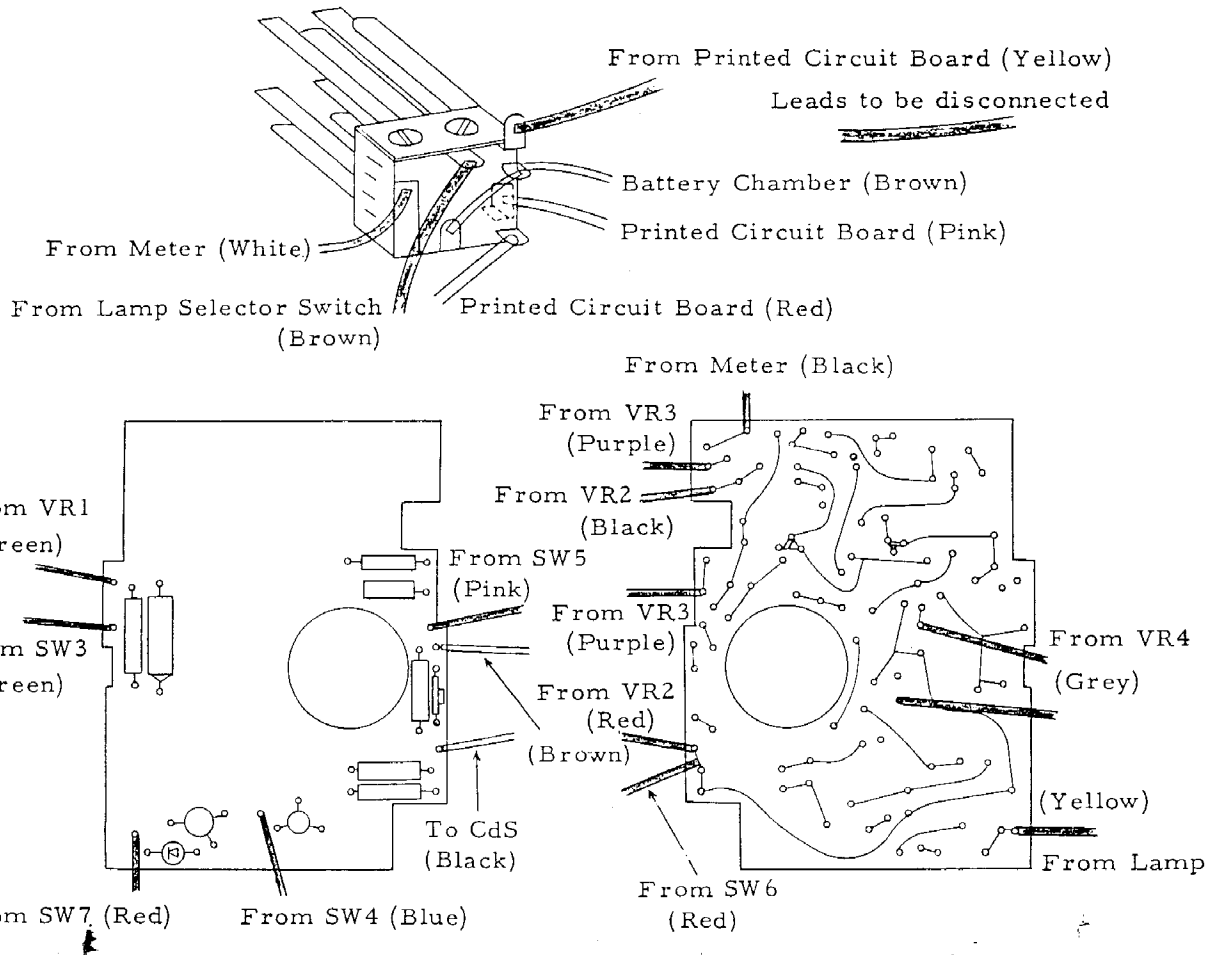

1.3 Optical Parts

1. Disassembly

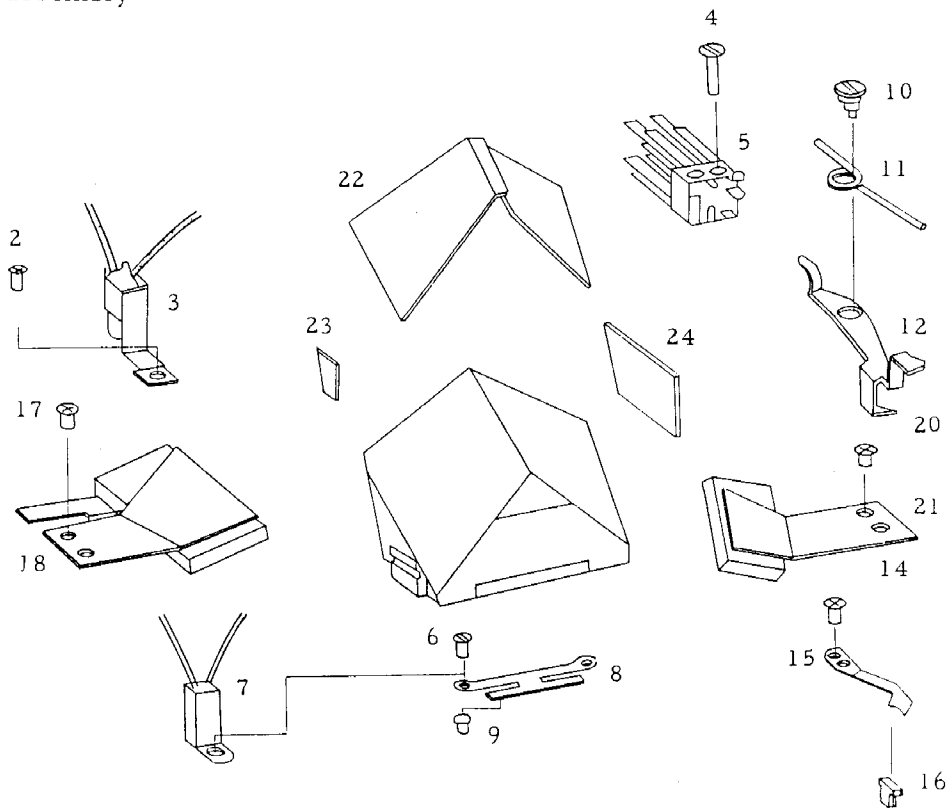

Remove each part in the following sequence.

Removal of Main Switch Unit (5)

(1) Disconnection of Eyepiece Shutter Switch Leads.

(2) Screw
X16-170158

(3) Lamp
X61-7092

(4) Screw
X91-143564 x 2

(5) Main Switch Unit

Removal of CdS (7)

(6) Screw
X21-140128 x 2

(7) CdS x 2

(8) Spring
97-7654

(9) Set Pin
13-9389

Removal of Lock Claw (12)

(10) Screw
97-4325

(11) Spring
97-6753

(12) Lock Claw
43-5137

(13) Lock Release Button
43-5138

	(14) $\frac{\text{Screw}}{\text{X16-170158}}$	(15) $\frac{\text{Spring}}{97-7655}$
	(16) $\frac{\text{Pin}}{13-9763}$	
Removal of Pentaprism (25)	(17) $\frac{\text{Screw}}{\text{X16-170208}} \times 2$	(18) $\frac{\text{Pentaprism Holder(Right)}}{43-5141}$
	(20) $\frac{\text{Screw}}{\text{X16-170208}} \times 2$	(21) $\frac{\text{Pentaprism Holder(Left)}}{43-5142}$
	(22) $\frac{\text{Protective Cover}}{13-9755}$	(23) $\frac{\text{Spacer(R)}}{13-9774}$
	(24) $\frac{\text{Spacer(L)}}{13-9775}$	(25) $\frac{\text{Pentaprism}}{12-0252}$

2. Assembly

- 1) Put Polyester tape on the Pentaprism where the removed prism had tape.
- 2) Install 0.4mm spacer at the left side of the pentaprism.
See Fig. below.
- 3) Eliminate pentaprism play by installing spacer (13-9775) at the right side while pushing the pentaprism forward.
- 4) Installing Pentaprism Protective Cover and Pentaprism Holder (43-5142), mount Pentaprism Holder (13-9755)
- 5) Mount Lock Claw, Main Switch Unit and Lamp.
- 6) Solder Eyepiece Shutter Switch.
- 7) Meter Base Plate.

Spacer
(13-9775)

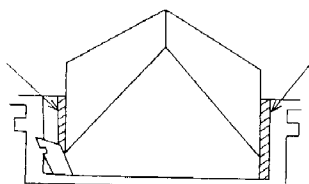

Spacer
(13-9774)

(Note) When detaching the Pentaprism from or mounting on the Base Plate, bring the pentaprism near the right side or the small Finder Information prism may be damaged.

(Note) When the Booster is installed on the camera, set to ASA 100, 1/30sec., and the booster turned on; the entire information window must be visible.

2. Adjustment

2.1 Booster Lock Claw Position

1. Checking:

The booster should be installed securely on F-1 by this claw, and the entire viewfinder must be visible.

2. Adjustment

Adjust the claw position by the opening of Lock Claw (43-5137) and Screw (97-4325).

2.2 Clutch Mounting Position

1. Checking:

When the clutch engages the F1 Shutter Speed Dial, the booster Shutter Speed Dial must turn smoothly.

2. Adjustment

Obtain the proper mounting position by moving Shutter Base Plate (49-0363).

(Reference) Limit:

$14.3 \pm 0.1\text{mm}$ from Booster rail side face.

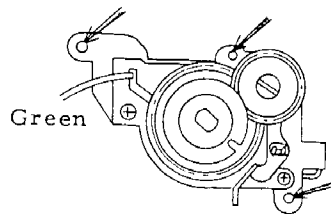

Fig. 1

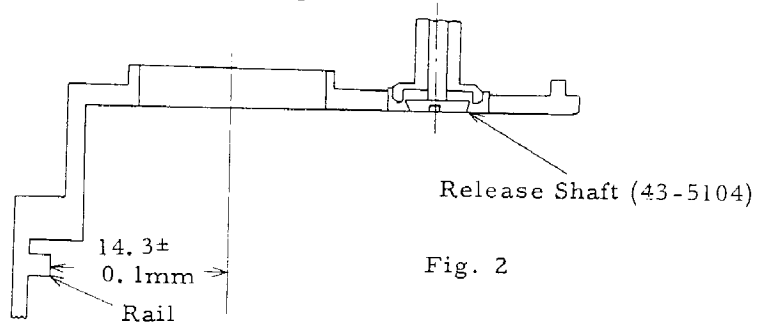

Fig. 2

2.3 Variable Resistor and Shutter Speed Dial Position

1. Detach Idler Gear (49-0384).

2. Set the variable resistor (VR-2) to EV-3. (Fully CCW against the stopper)

3. Setting the shutter speed dial to ASA25, 60 sec, mount it on shutter Speed Dial Shaft.

4. Assemble the idler gear so that both VR1 and VR2 touch the their stoppers.

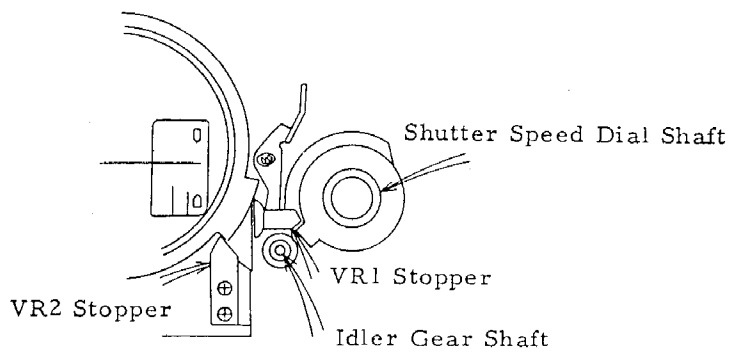

Fig. 3

2.4 Normal Position of Release Button

1. Checking:

When mounting the booster on F-1, there should be a clearance of 0.6 to 1.0mm between the lower face of the release button and the camera shutter button.

2. Adjustment

Adjust the release button position by putting washers on the Release Shaft (43-5104).

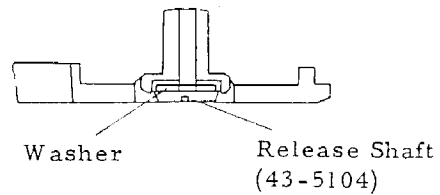

2.5 Locked Position of Shutter Release Button

When releasing the camera shutter setting the shutter speed dial to "B", the shutter release button must lock before 1st Curtain moves, and besides, it must be locked at a position deep enough that the 2nd curtain is clamped.

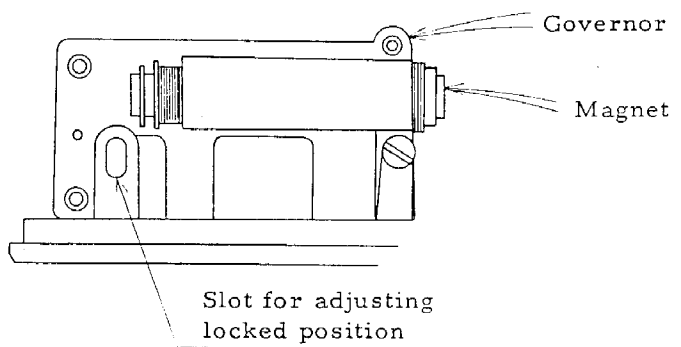

Fig. 4

2.6 Count Switch and Lamp Flashing Switch

1.

The switch should turn on before the 1st curtain moves and turn off just as the 2nd curtain starts.

2. Adjustment

Adjust the switch by turning the eccentric screw of the shutter button unit.

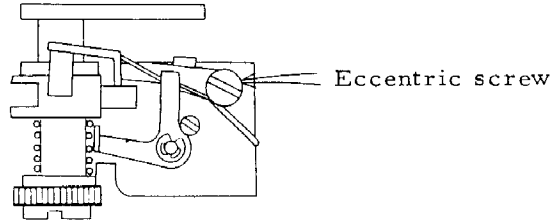
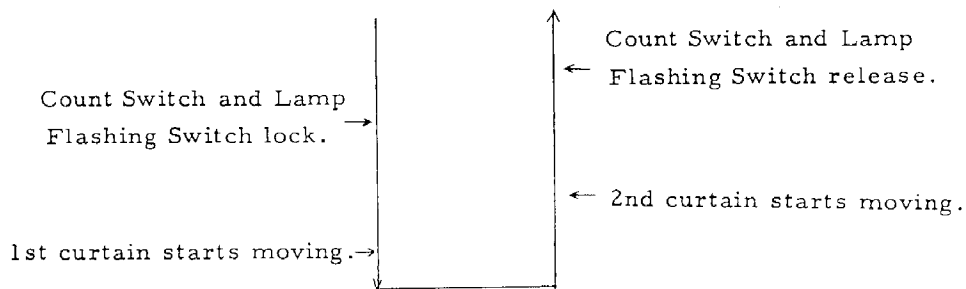

Fig. 5

2.7 Release Sequence



3. Replacement and Adjustment of CdS and Variable Resistor

3.1 Removal of CdS and Variable Resistor (Omitted.)

3.2 Assembly

1. Adjust the position of Shutter Speed Dial and the variable resistor.
2. Set the shutter speed dial to ASA25, 8 sec.
3. Disconnect the lead of the resistor wiper terminal.
4. Set the resistance value across the resistor wiper terminals to that of CdS EV0. (Data will be attached to the new parts.)
5. Solder the resistor wiper terminal.

Note: The CdS's and VR must be changed as a unit.

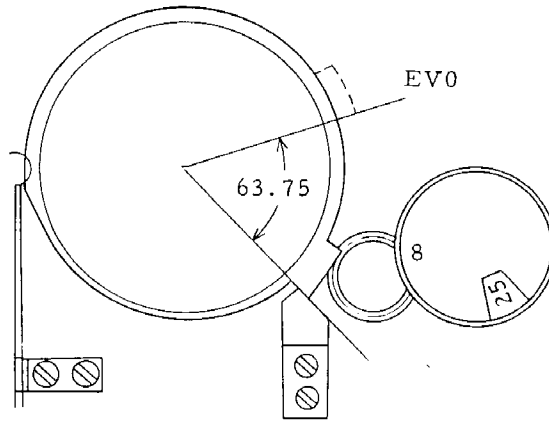
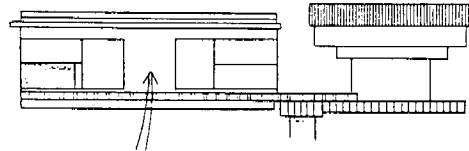

Fig. 6

3.3 Adjustment of Meter Accuracy

1. Completely assemble the booster.
2. Remove the Top Cover Cap (43-5179).
3. Adjust the meter index with the variable resistor (VR-3, 10K Ω) so that the meter needle points to the center of the index mark.
4. Where it is impossible to adjust it with VR-3, make adjustment by changing the position of the large variable resistor (VR-2) ring.
5. Part to be adjusted
 - 1) How to turn variable resistor



Loosen this set screw.

Fig. 7

2) Meter accuracy

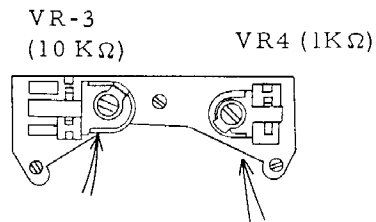

Check point when using 1% ND filter in F-1 with FD Lens
 50mm 1:1.4 is; EV 0, ASA25, 4 sec, F5.6, 439.0cd/m².
 With Standard CANON 1% Filter ND=1.46%, B=300.7 cd/m².

Fig. 8

(Note) 1. When transmission of the ND filter is not exactly 1%, calculate the brightness from the following formula;

$$B(\text{cd/m}^2) = \frac{K}{T} \frac{A^2}{S} \times \frac{1}{t}$$

A: FNo.
S: ASA
K: 14

T: Exposure time

t: Transmission factor of the ND filter (in decimal, not %)

(Note) 2. Since the CdS meter is very sensitive to any light, the light source, camera, and booster must be isolated from outside light. A dark room is the best place to perform this adjustment.

(Note) 3. Because the responding time of CdS meter is slow, wait 10 to 20 sec after adjustment before checking needle position.

Layout of EE accuracy measuring instruments

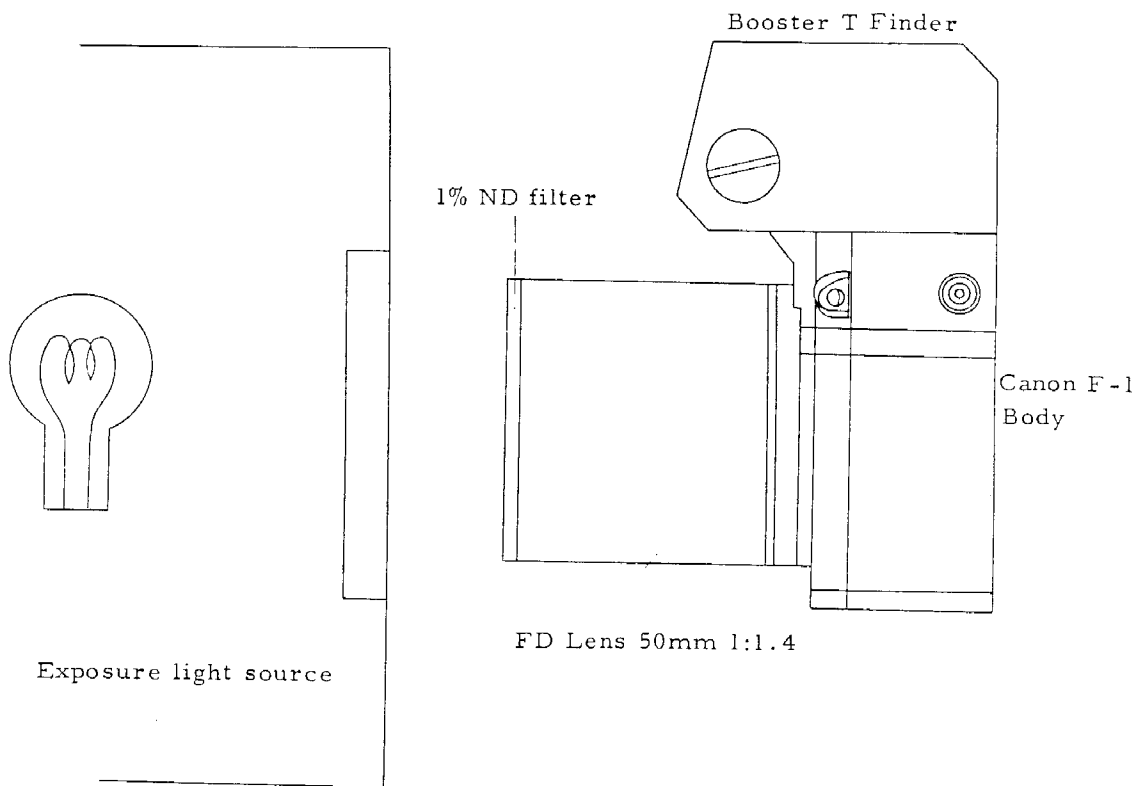

3.4 Timer

Check the timer function by using any desired watch.

Adjustment

Adjust the timer with the variable resistor VR4. See Fig. 8.

Lower Limit	2.1 sec	2.8	5.9	11.5	21	42
Timer Setting	3 sec	4 sec	8 sec	15 sec	30 sec	60 sec
Upper Limit	3.9 sec	5.2	10.4	19.5	39	84

Note: These time limits are equal to $\pm 0.3EV$

3.5 Checker

Checker needle:

Out of blue zone at 4.5V

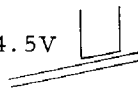

In blue zone at 4.8V



Fig. 9

Adjustment

Make adjustment with VR5.

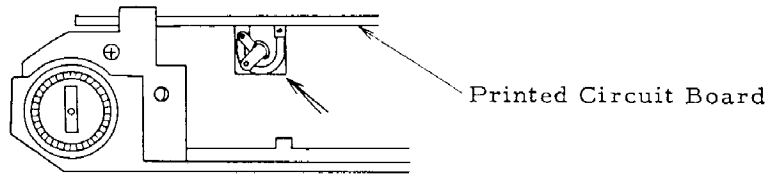
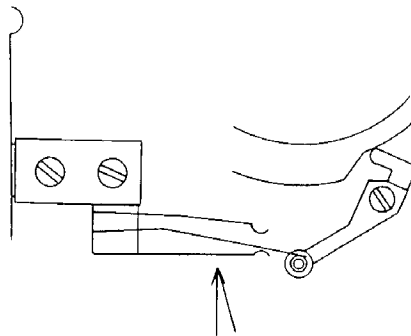

Fig. 10

3.6 Lamp Selector Switch

The lamp on the top of the booster indicates the booster meter is operating and the one on the side indicates the camera meter is on. They should never be on at the same time.

Set at ASA25, the lamps must switch over between 1 and 3 sec on the scale of the Shutter Speed Dial.



Make adjustment by bending the contact.

Fig. 11

4. Troubleshooting Chart

<u>Trouble</u>	<u>Cause/Checkpoint</u>	<u>Remedy</u>
When an electrical trouble occurs, first clean the contacts and check soldering.		
1. Release button will not lock	1.1 Governor unit lock position	Adjust (See Fig. 4)
	1.2 If current is flowing through the magnet 1. VR4 misadjusted 2. Sw3 not making good contact	Clean and adjust the contacts
2. Button will not unlock	2.1 If Magnet is working	Adjust 43-5140 (Clutch release lever)
	2.2 If magnet is not working, check 1. Magnet coil 2. VR1 soldering 3. Tr4, 5, and 6	Replace magnet Replace the defective Transistor
3. Lamp (L 1)	3.1 Lamp (L 1) does not light, check 1. Battery 2. Soldering of Battery contact leads 3. Sw1	3. Clean and adjust the switch contacts
	3.2 Lamp (L1 - Camera meter On) lights but L2 (Booster meter On) does not. 1. L2 lead soldering 2. L2 filament 3. SW2	3. Clean and adjust 3. SW2
	3.3 L2 does not light in B.C. (Battery Check)	Clean and adjust SW7
	3.4 L2 does not flash during long exposure 1. SW4 2. Tr1, 2 or 3, Check by putting a resistor (about 1K) across Tr2 E-C	1. Clean and adjust SW4 2. If the light flashes Tr1 or 2 is bad, If not Tr3 is bad.

CANON SERVICE TOOLS LIST

CANON BOOSTER T FINDER
(REF. NO. 5-60091)

TEST EQUIPMENT

<u>Use</u>	<u>Names of Test Equipment</u>
Exposure Meter	<ol style="list-style-type: none"> 1. Inspection Device for Canon Meter-1 2. Standard Checker-2 (CdS) 3. 1% ND Filter 55mm

SPECIAL SCREW DRIVERS

USE

T0630-13-8154-3



Tightening
Shutter Dial
(Common to FT)

T0630-13-8627-3



Tightening
Eyepiece Shutter
Dial
(Common to FT)

T06A-33-1408-2

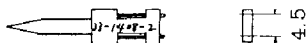

Tightening
Main Switch
(Common to Zoom 8)