

CANON T50 SERVICE MANUAL

CONTENTS

	Page	Address
Preparations	ii	A-5
I. Disassembly/Assembly	1	A-7
1. Covers	1	A-7
2. Upper Cover Parts	3	A-9
3. Main Flexible PC Board Removal	5	A-11
4. Viewfinder Parts	9	B-1
5. Back Cover Removal	11	B-3
6. Front Panel Removal	13	B-5
7. Front Panel Parts	15	B-7
8. Winding and Rewind	21	B-13
9. Upper Winding Baseplate Parts	25	C-3
10. Lower Winding Baseplate Parts	28	C-6
11. Shutter Unit Removal	31	C-9
II. Adjustments	34	C-12
1. Frame Counter	34	C-12
2. Shutter	37	D-1
3. Automatic Exposure (AE)	38	D-2
4. SW4-1, SW4-2	39	D-3
5. Rewind Switch (SW12)	41	D-5
6. Post IC Replacement Adjustments	42	D-6
III. Lubricants, Adhesives, etc.	46	D-10
1. External Parts	46	D-10
2. Body	48	D-12
3. Front Panel	54	E-4

1. Preparations

This model has a first frame positioning circuit which automatically sets the shutter speed to 1/1000 second until the frame counter reaches "1". This prevents long slow shutter speeds during loading. When testing the camera with back cover open the frame counter return lever must be depressed so the frame counter advances to "1".

2. Since the T50 is largely made of plastic, care must be taken to avoid exposing it to solvents or grease.
3. Self-tapping screws are used; when replacing parts such as the body, be careful to avoid looseness and stripping of threads due to overtightening.
4. Plastic gears are used; when doing work which involves soldering, be careful to protect them and other parts from solder drops.
5. After completing repairs, be sure to clean the spool rubber.
6. Be careful to avoid touching the shutter curtains.
7. Note that the following adjustments are covered in the Disassembly/Assembly section of this manual.
 - A. Perforation adjustment ... Take-up and rewind, page 23.
 - B. Spool torque adjustment ... Take-up and rewind, page 24.
 - C. AE unit, mirror mechanism adjustment ... Front panel components, page 16

I. DISASSEMBLY/ASSEMBLY

I-1 COVERS

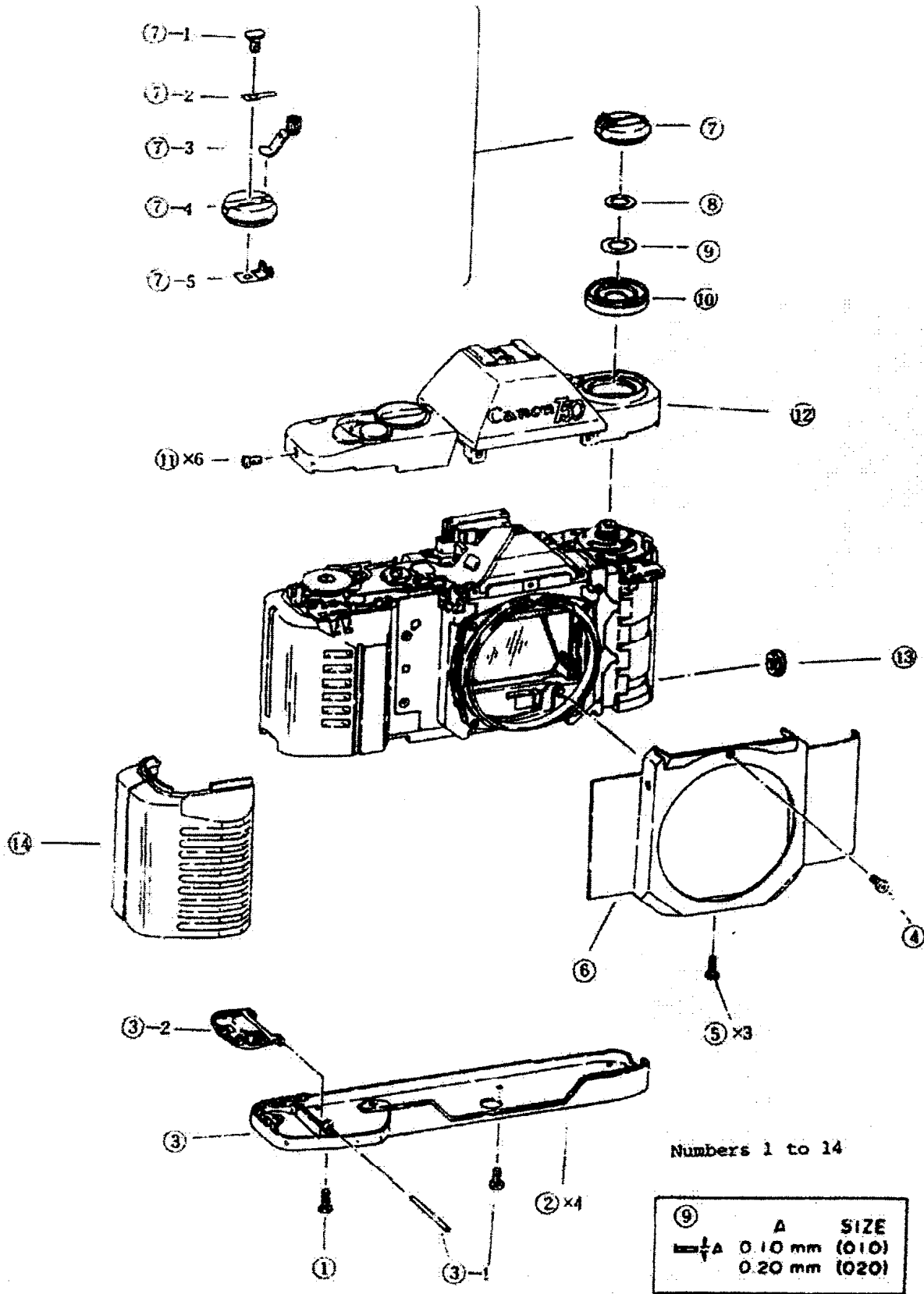

I. DISASSEMBLY/ASSEMBLY

I-1 COVERS

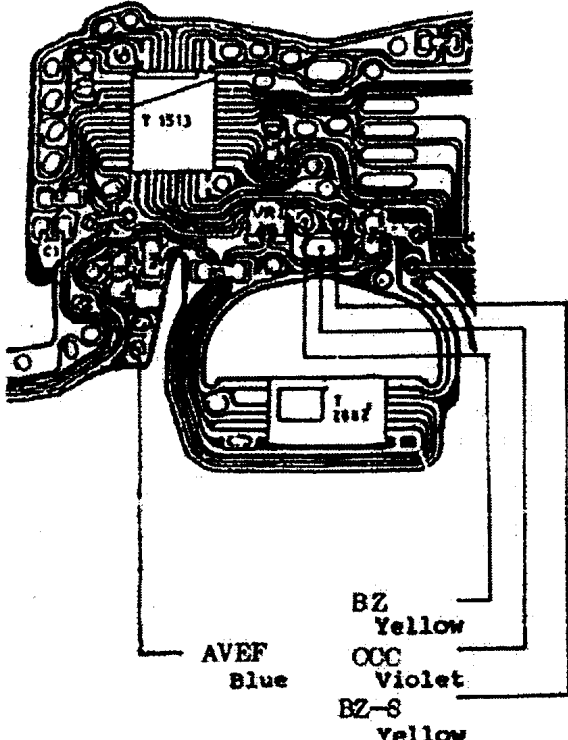
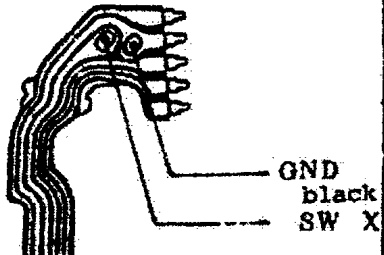
Disassembly Notes	Assembly Notes
<p>Note: Be careful to avoid damaging the six upper cover lead lines.</p>  <p>Fig. 1</p>  <p>Fig. 2</p>	<ol style="list-style-type: none"> 1. A short screw must be used as apron screw (4); longer ones will damage the pentaprism, and therefore must not be used. 2. A long screw is used as bottom cover screw (1). 3. Ensure that thrust play in the ASA film speed dial is no more than 0.1 mm. This can be adjusted with washer (9). 4. When positioning the lead lines in the cover, it is convenient to rotate the cover to either the right or left. 5. There is no need to remove the grip rubber, either during disassembly or assembly.

Note: Numbers in parentheses in the text correspond to circled numbers on the facing page. Disassemble in normal order and reassemble in reverse order.

I. DISASSEMBLY/ASSEMBLY
 I-2 UPPER COVER PARTS

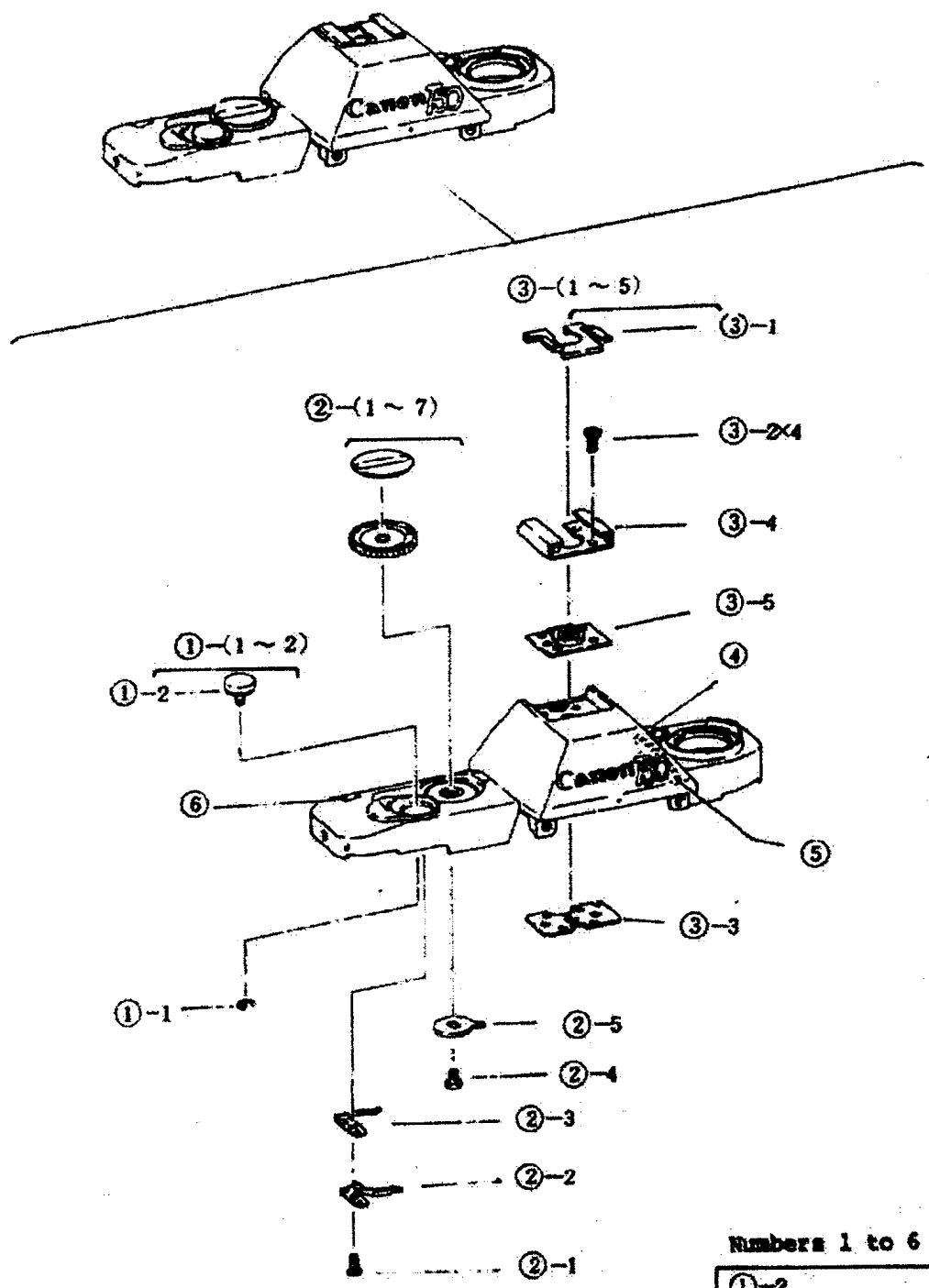

Numbers 1 to 6

①-2	A	SIZE
	1.2 mm (012)	
	1.4 mm (014)	
	1.6 mm (016)	

5

I. DISASSEMBLY/ASSEMBLY

I-2 UPPER COVER PARTS

Disassembly Notes

1. Part (4) is a pressure fitted part.
2. Part numbers (2)-6, 2-7, (5) and (6) are fastened to each other with adhesive.

Assembly Notes

1. Button (1)-2 should project above the shutter button seat by 0.3 ± 0.2 mm (as viewed when the button is in the up position).
2. Alignment of the index mark of selector dial (2)-7 should be true whether the dial is rotated to a setting from the left or right.
3. The "click" torque required for parts (2)-2 and (2)-3 should be as follows (as measured at the start of movement):

L ↔ P - 300 ± 100 gr/cm
P ↔ S

L ↔ BC - 200 ± 70 gr/cm
4. Thrust play of selector dial (2)-6 should be less than 0.3 mm.
5. Part (5) should be affixed using G103.

Note: Numbers in parentheses in the text correspond to circled numbers on the facing page. Disassemble in normal order and reassemble in reverse order.

I. DISASSEMBLY/ASSEMBLY

I-3 MAIN FLEXIBLE PC BOARD REMOVAL

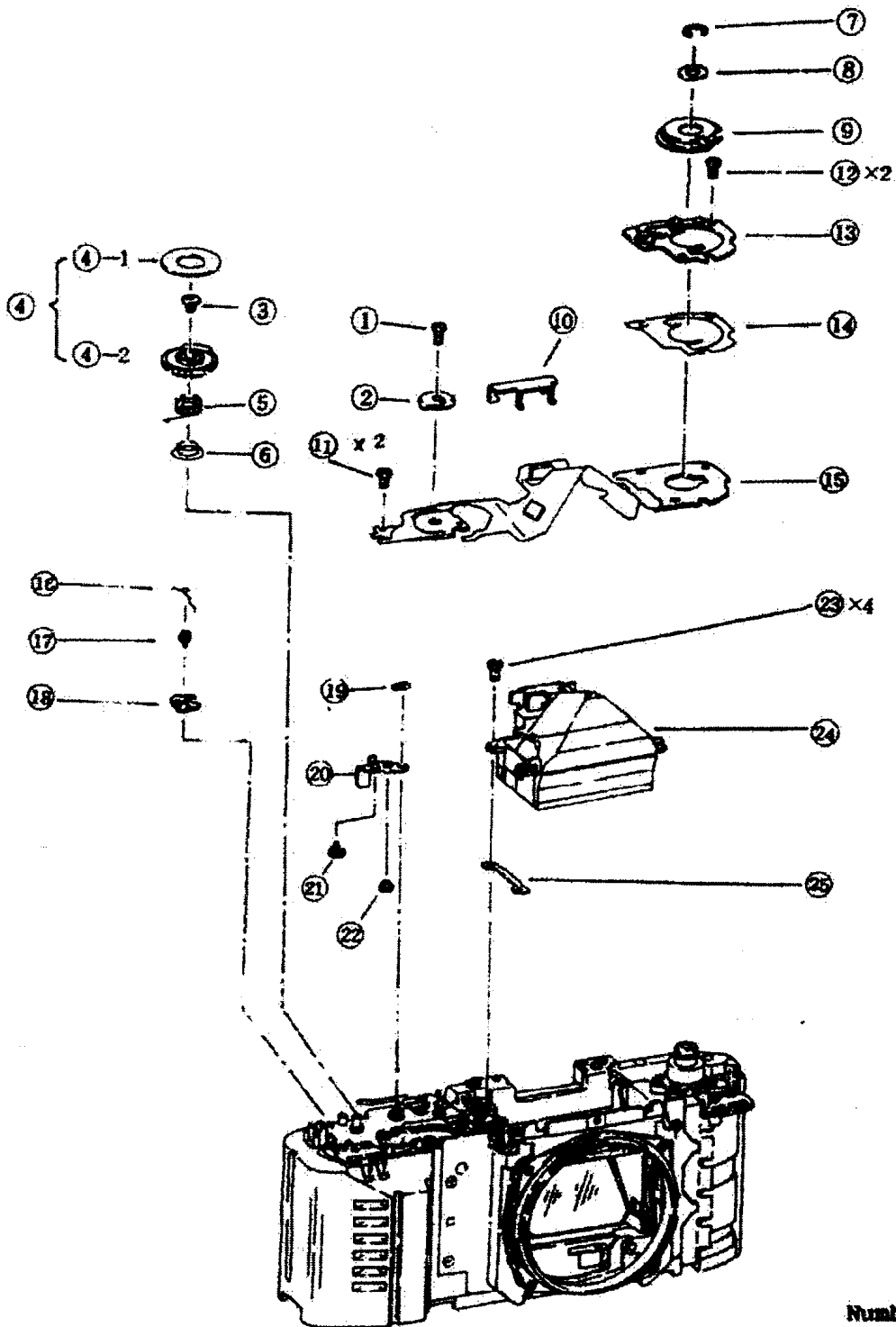

Numbers 1 to 27

$\frac{\text{A}}{\text{A}}$	A	SIZE
$\frac{0.05}{\text{A}}$	0.05 mm	(005)
$\frac{0.10}{\text{A}}$	0.10 mm	(010)
$\frac{0.20}{\text{A}}$	0.20 mm	(020)

I. DISASSEMBLY/ASSEMBLY

I-3 MAIN FLEXIBLE PC BOARD REMOVAL

Notes Concerning Disassembly

1. Part numbers (16) to (25) in the figure are not related to this section.
2. When unsoldering the lead lines, be careful to prevent drops of solder from falling inside the body.
3. Be sure to remove the protective pentaprism cover before unsoldering the flexible PC board.

Notes Concerning Assembly

1. When installing the flexible PC board, confirm that its GND is properly soldered and that the screw above the front panel stiffener is properly tightened.
2. Be sure that the shutter flexible PC board is properly soldered.
3. Be sure that the selector dial is set to the program position after assembly has been completed (battery installation with it set to the battery check position will result in battery wear).



Fig. 3

Note: Numbers in parentheses in the text correspond to circled numbers on the facing page. Disassemble in normal order and reassemble in reverse order.

I. DISASSEMBLY/ASSEMBLY

I-3 MAIN FLEXIBLE PC BOARD REMOVAL

Lead lines

- ① ~ ⑥ — Lower surface board
- ⑦ ~ ⑩ — LED board
- ⑪ ~ ⑯ — AE unit
- ⑰ ⑱ — Battery compartment
- ⑲ — CNT board

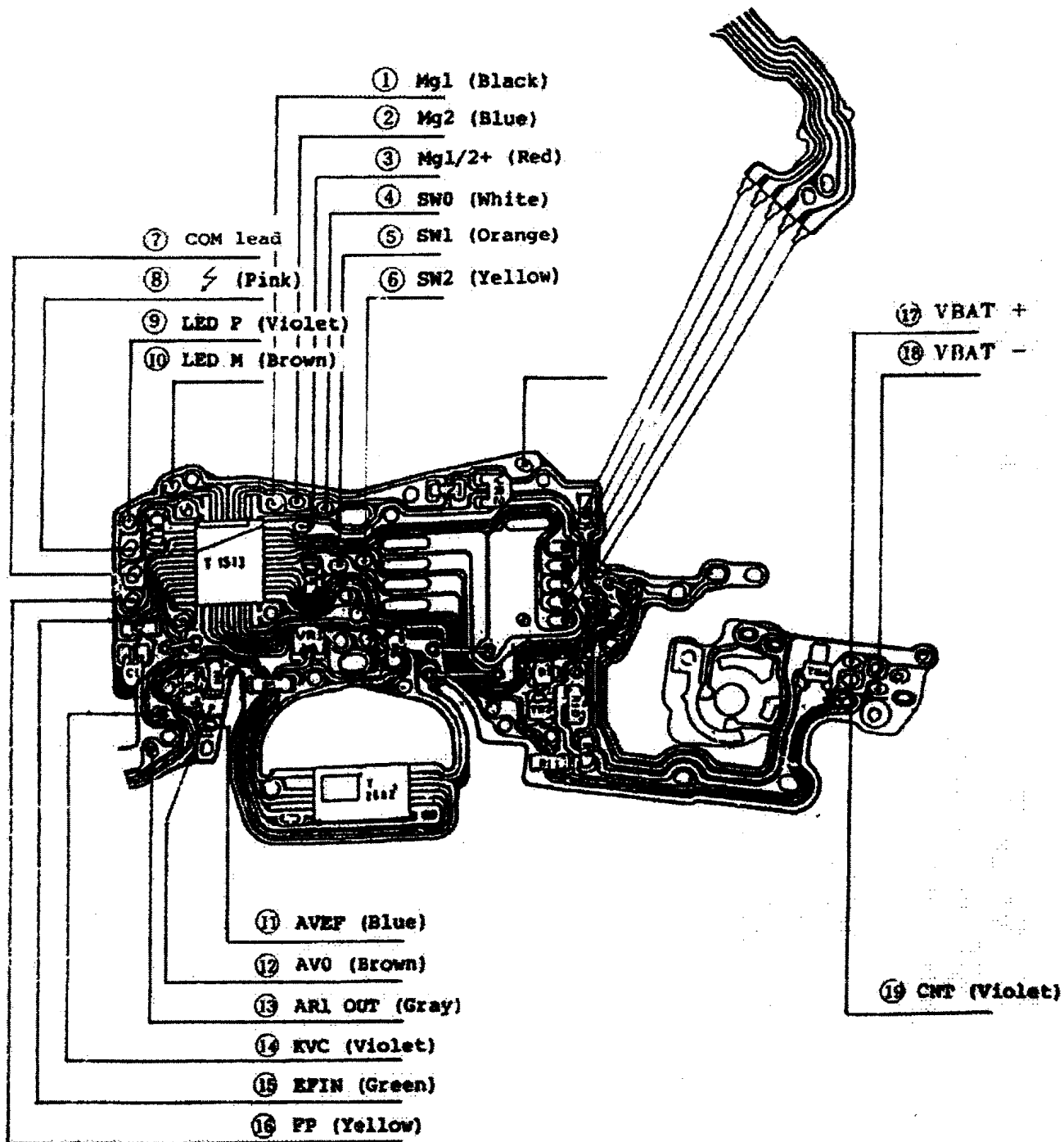

Fig. 4

I. DISASSEMBLY/ASSEMBLY

I-3 MAIN FLEXIBLE PC BOARD REMOVAL

Disassembly Note

Main Flexible PC Board Removal

o See page 7 concerning removal of leads.

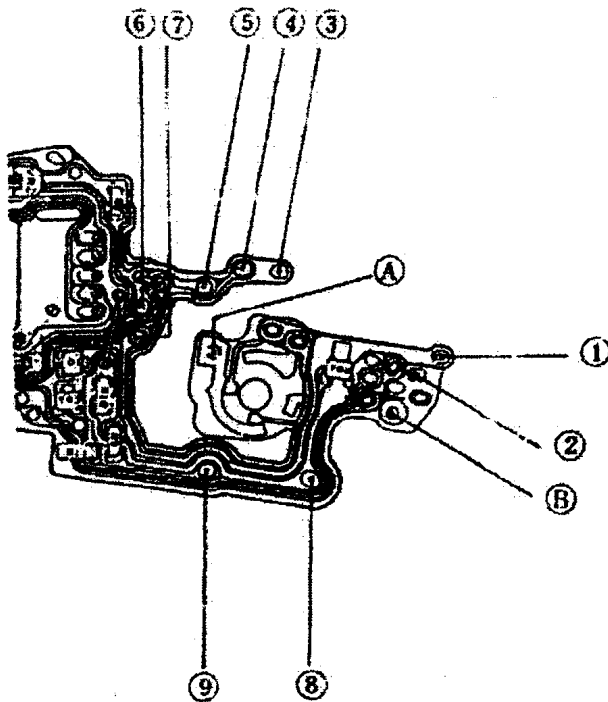

Fig. 5

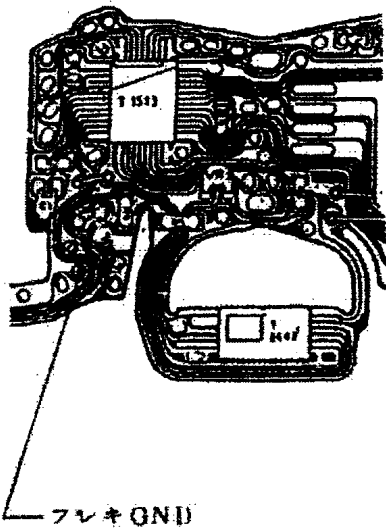

Fig. 6

Before unsoldering the main flexible PC board, unsolder the shutter flexible PC board.

A - Selector board GND screw.

B - Main flexible PC board GND screw.

- (1) Motor (+)
- (2) Motor (-)
- (3) SW0
- (4) SW1
- (5) SW2
- (6) SW4-1
- (7) SW4-2
- (8,9) SWR

Notes:

o Leads (1) to (9) are soldered to through holes in the flexible PC board; when unsoldering them, be careful to avoid damaging the board.

o The shutter flexible PC board is soldered into holes in the main flexible PC board; be careful to avoid damaging this PC board.

o The GND point for the flexible PC board (Figure 6) is a through hole; be careful to avoid damaging the board when soldering or unsoldering this joint. Be sure to unsolder this connection when removing the front plate.

o During assembly, be sure that all joints are properly soldered and that the ground screw is securely fastened.

Note: Numbers in parentheses in the text correspond to circled numbers on the facing page. Disassemble in normal order and reassemble in reverse order.

I. DISASSEMBLY/ASSEMBLY
I-4 VIEWFINDER PARTS

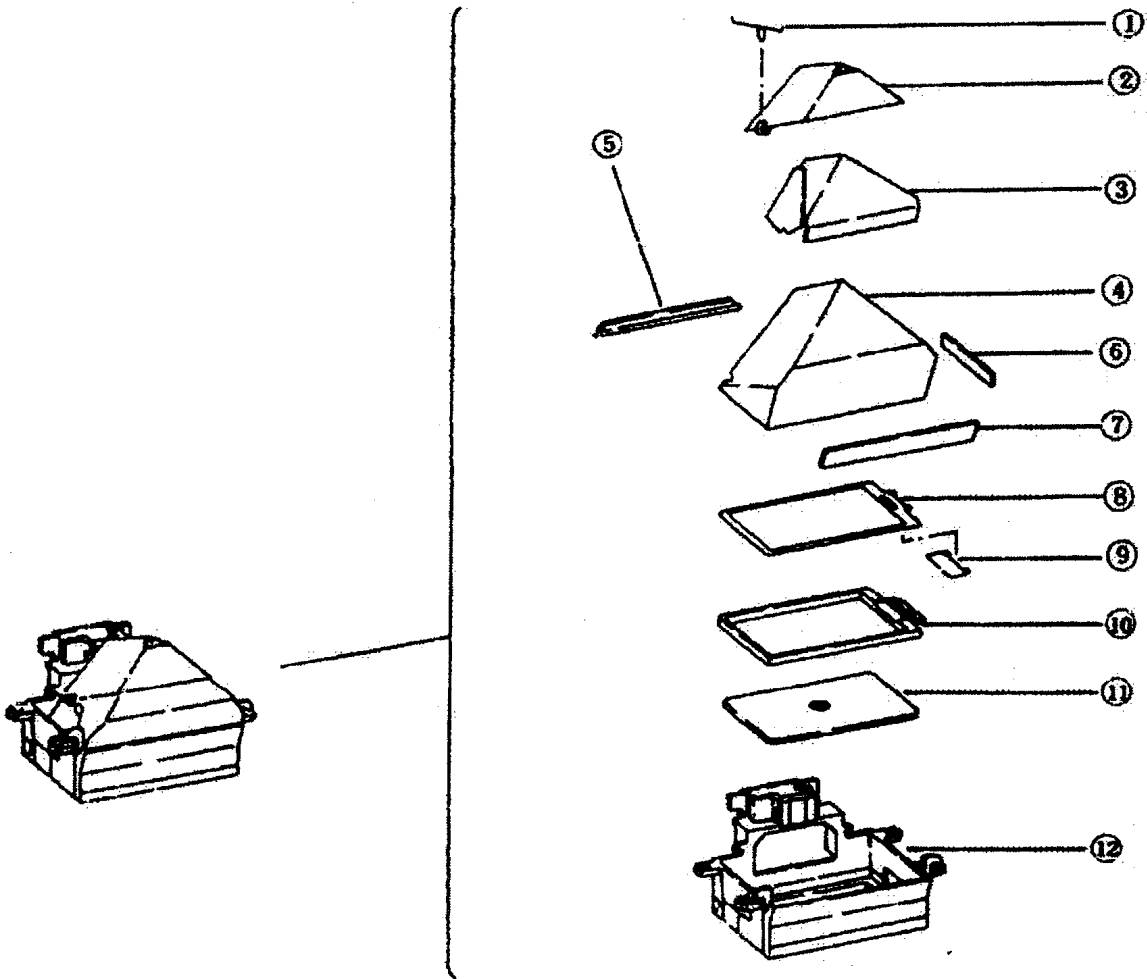

Numbers 1 to 12

I. DISASSEMBLY/ASSEMBLY

I-4 VIEW FINDER PARTS

Disassembly Notes

1. Be careful to avoid dropping the focusing washer (see part numbers (23)-(25) in the disassembly drawing on page 6).
2. When removing the viewfinder unit after removing only the front panel unit, be careful to avoid damaging the flexible PC board when unsoldering the SPC part of the main flexible PC board and the ground connection of the front plate.

Assembly Notes

1. Be careful to avoid scratching either surface of the focusing screen.
2. When installing the indicator panel, be careful to avoid touching the indicators.
3. After installing the pentaprism, be sure to affix tape for keeping out dust.

Adjustment Dimensions

Part number (25) on page 6 is used for adjusting the focus of the focusing screen.

Note: Numbers in parentheses in the text correspond to circled numbers on the facing page. Disassemble in normal order and reassemble in reverse order.

I. DISASSEMBLY/ASSEMBLY
I-5 BACK COVER REMOVAL

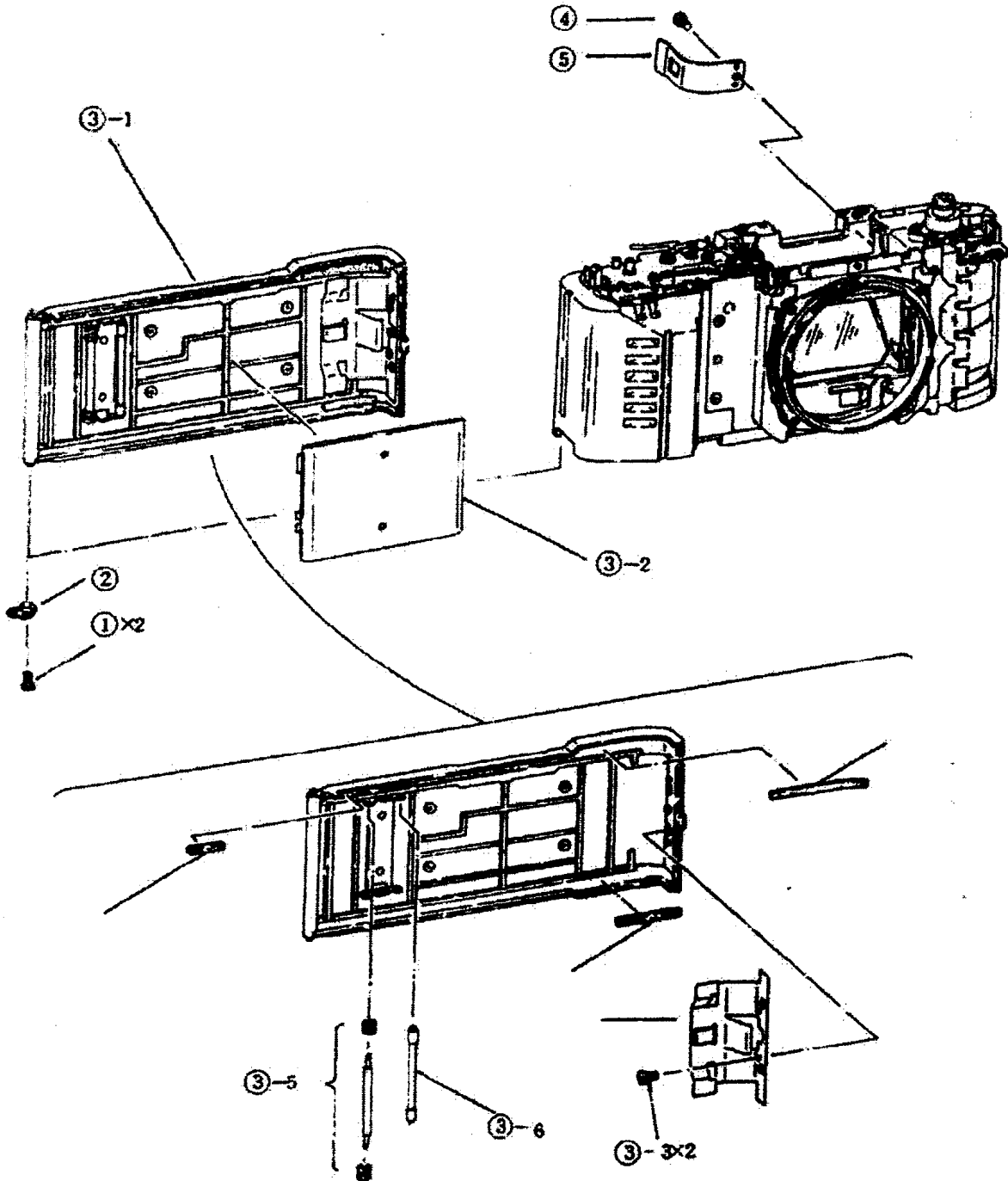

Numbers 1 to 5

I. DISASSEMBLY/ASSEMBLY

Back Cover Parts

Back Cover Removal.

Disassembly Notes

1. Only the bottom cover need be removed in order to replace the back cover.
-

Assembly and Adjustment Notes

1. Since the back cover is made of plastic, be sure that the self-tapping screws (3)-3 holding the cartridge retainer (3) are securely seated when replacing the back cover.
2. A small quantity of PL-015 should be applied to the back cover hinge.

Note: Numbers in parentheses in the text correspond to circled numbers on the facing page. Disassemble in normal order and reassemble in reverse order.

I. DISASSEMBLY/ASSEMBLY
 I-6 FRONT PANEL REMOVAL

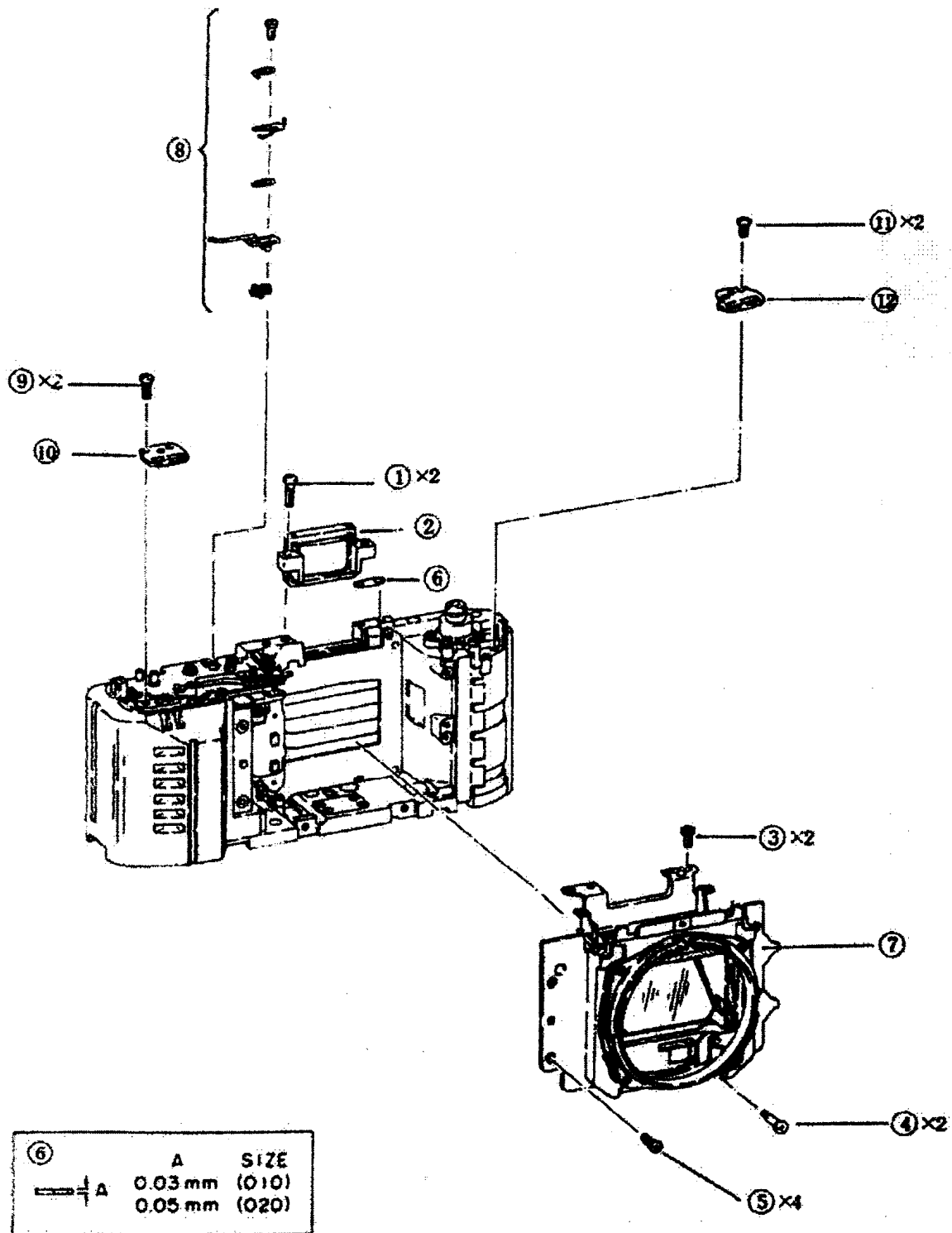

Numbers 1 to 12

Front Panel

Disassembly Note

Front panel removal

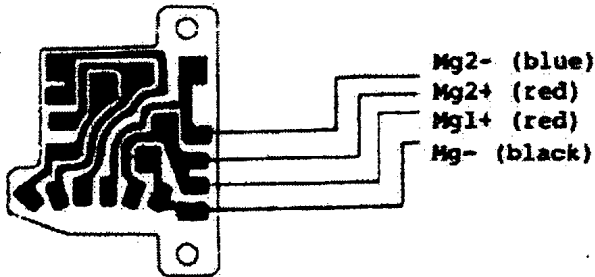

Fig. 6

After removing the four leads indicated in Figure 6, disassemble according to the procedure shown on page 14.

Assembly Note

Front Panel Installation

- o Install the front plate with the shutter open and the mirror up.
- o After installing the front panel, replace washer (6) with one selected to provide a clearance of no more than 0.03 mm between the front panel reinforcing panel and the body.

Front Panel Reinforcement

In order to increase the flange to focal plane precision, a new design is used for the mirror box. In addition to the screws in the front panel, four screws are installed vertically at the rear of the mirror box (Two of the four also serve to hold the eyepiece lens in place).

Note: Numbers in parentheses in the text correspond to circled numbers on the facing page. Disassemble in normal order and reassemble in reverse order.

I. DISASSEMBLY/ASSEMBLY

1-7 FRONT PANEL PARTS

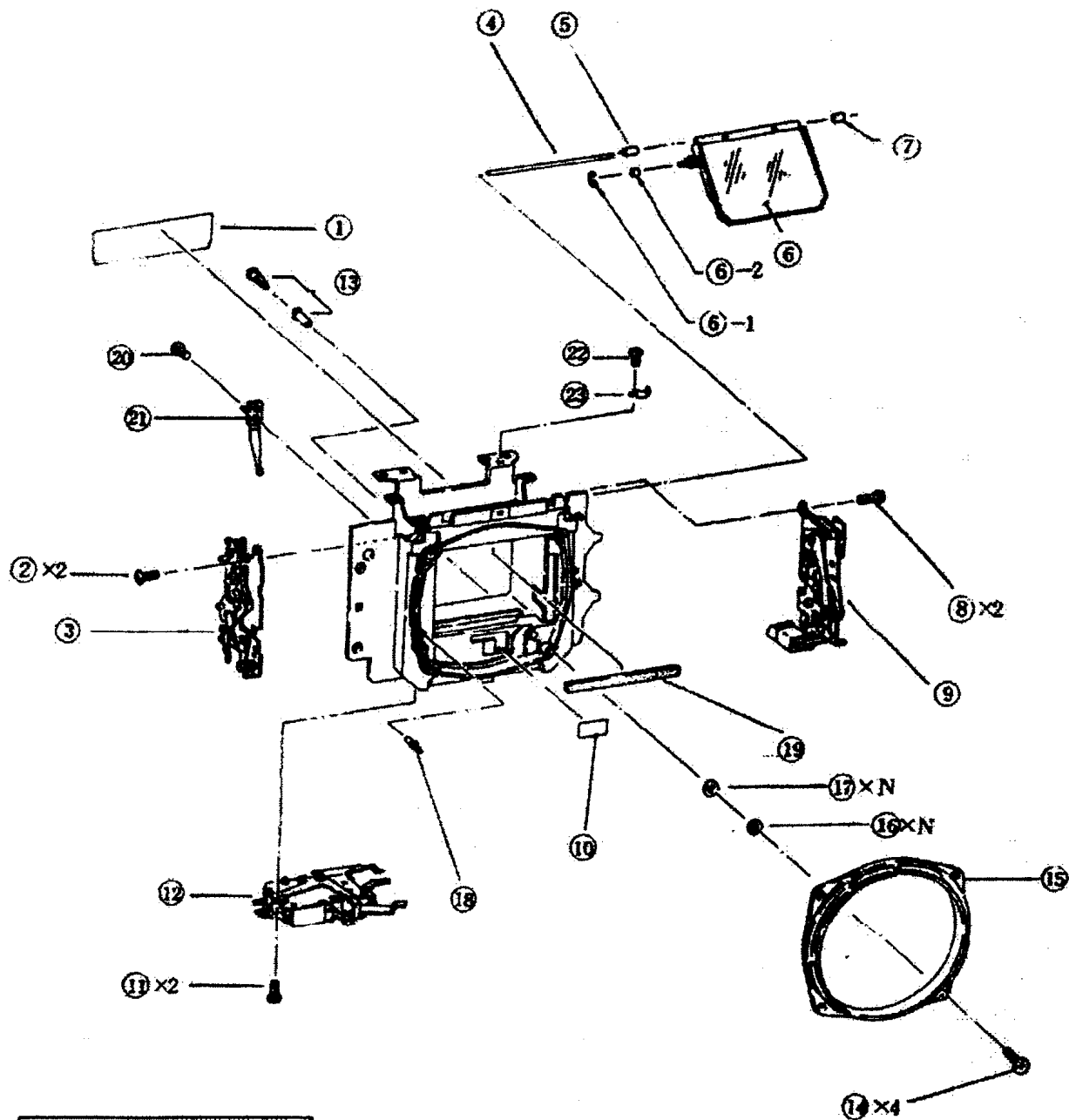

⑦	A	SIZE
	2.6 mm	(010)
	2.7 mm	(020)
	2.8 mm	(030)

Numbers 1 to 23

⑥-2	A	SIZE
	2.3 mm	(050)
	2.4 mm	(060)
	2.5 mm	(070)
	2.6 mm	(080)

⑮	A	SIZE
	14-2308-000	5.5mm - Standard
	CAI-1113-000	5.2mm
		Special service port (0.3mm under standard)

I. DISASSEMBLY/ASSEMBLY

I-7 FRONT PANEL PARTS

1. AE Unit Adjustment

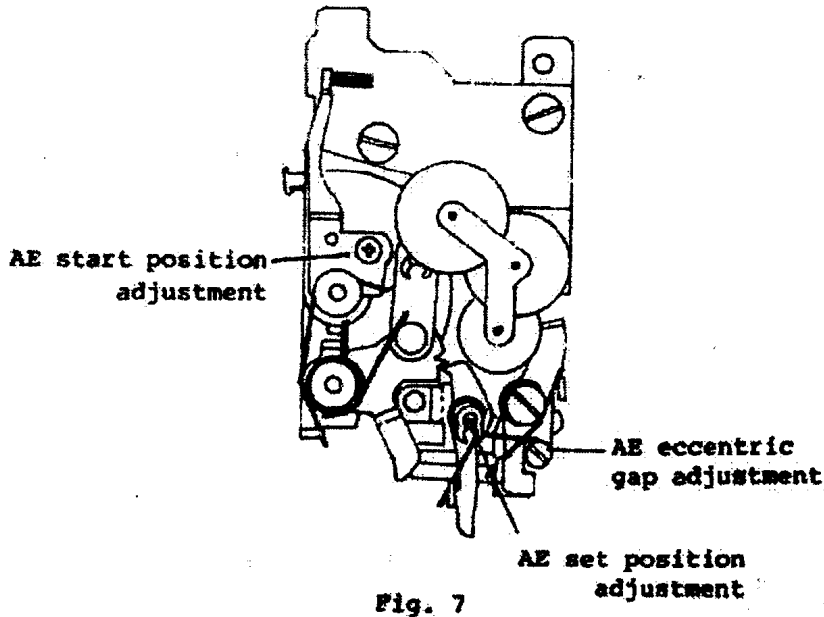

2. AE Eccentric Gap Adjustment

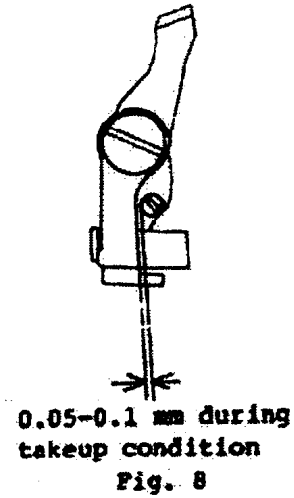

3. Set Position Adjustment

Attach a tool standard lens and read the AE set position; adjust by turning the eccentric. (Norm: $0.4 \pm 0.2F$).

- o One or two steps of overcharge is sufficient for the front panel by itself.
- o If a tool standard lens is not available, install an ordinary standard lens (to place a load on the aperture signal charge lever) and adjust to obtain seven turns plus six teeth, ± 1 tooth.

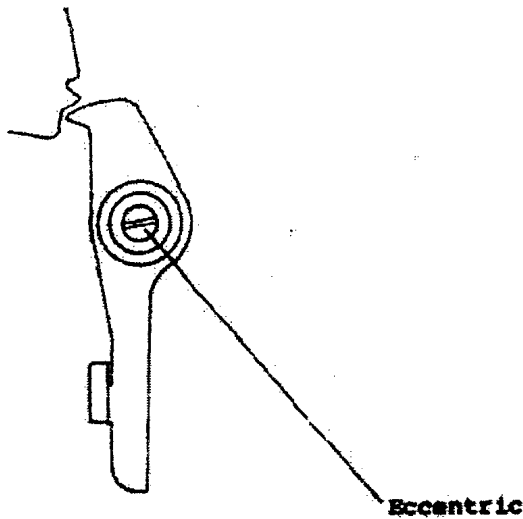
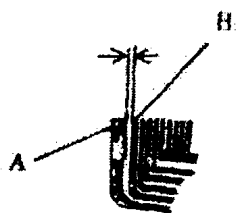
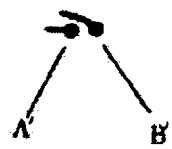
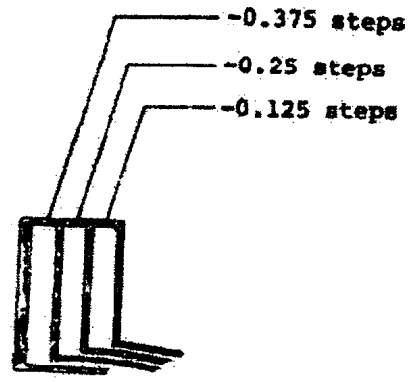

Fig. 9

Note: Numbers in parentheses in the text correspond to circled numbers on the facing page. Disassemble in normal order and reassemble in reverse order.

I. DISASSEMBLY/ASSEMBLY

I-7 FRONT PANEL PARTS

Disassembly Note	Assembly Note
<p>4. AE Start Position Adjustment</p>   <p>Fig. 10</p>	<ul style="list-style-type: none"> o Attach a standard lens. o With the front panel set for automatic exposure, loosen the screw indicated in Figure 7 on page 17 and adjust the AE brush so that its tip is positioned between A and B in Figure 10. After completing the adjustment, paint the head of the screw with G103. <p>Connect the + probe of a multimeter to A' and the probe to the metal part of the AE unit; adjustment is satisfactory if there is no conductivity between the two points. Also confirm that there is no conductivity with the + probe of the multimeter connected to point B'.</p>
<p>5. AE Precision Adjustment</p>  <p>Fig. 11</p>	<p>AE precision can be adjusted by cutting the pattern as indicated in Figure 11. (However, adjustment is only possible in the direction indicated.)</p>

I. DISASSEMBLY/ASSEMBLY

I-7 FRONT PANEL PARTS

6. Mirror Installation Adjustment

- o See page 16 for procedures for installing the mirror.

Adjust for thrust play along the mirror axis by replacing collar 7.

Standard: 0.05 - 0.3 mm.

Drive pin collar adjustment

- o Adjust spacing between the mirror and the shock absorbing cushion by replacing collar (6)-2.

Standard:

From 0 to 1.0 mm

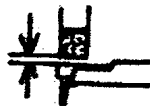

Fig. 12

Mirror 45° adjustment

Turn the 45° adjustment nut inside the mirror box with a hex wrench.

Standard:

Horizontal - Within 8'

Vertical - Within 3'

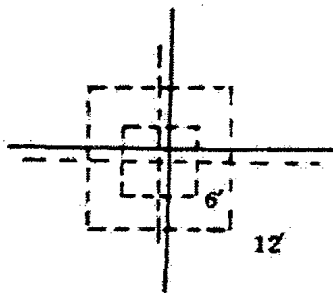

Fig. 13

Note: Since the accuracy of horizontal positioning is determined by component precision, replace the mirror box on units which do not meet the standard.

I. DISASSEMBLY/ASSEMBLY

I-7 FRONT PANEL PARTS

7. A-M Switching Position Adjustment

Standards:

0.2 - 0.7 mm from the mount surface

Contact resistance - 1 ohm or less

Adjust the switching position by bending the contacts; test contact resistance by connecting the + probe of a multimeter to the lead coming from SW11 and the - probe to the metal part of the front plate. Switching should occur when the aperture ring of a standard lens mounted on the front plate is turned to the A mark.

8. Mgl Minimum Holding Voltage

Standard: 1 V or less

Inspection Procedure

1. With the front panel unit set and a standard lens mounted, connect the + side of a regulated power source to the + lead of Mgl and the - side to the - lead.
2. Apply 3 V from the regulated power source.
3. Start the AE mechanism.
4. Reduce the voltage level from the regulated power source and read the voltage at which Mgl is released.

1. DISASSEMBLY/ASSEMBLY

I-7 FRONT PANEL PARTS

AVO adjustment

1. Connect the + probe of a multimeter to the brown lead from the AE unit and ground the - probe to the metal part of the front panel.
2. Push the maximum aperture correction pin in as far as it will go with your finger and read the resistance from the multimeter. This is the resistance for f/1.2. Gradually let the pin return watching the meter to keep track of the switching points passed. Read and record the resistances at the fifth (f/2.5) and sixth (f/2.8) steps.
3. Set a depth gauge to 7.025 mm and check whether the AVO height is correct by confirming that switching between the f/2.5 and f/2.8 levels occurs within ± 0.05 mm of this height.
4. AVO is adjusted by means of a screw inside the full aperture compensation pin. (The screw is locked with G103; dissolve it with ketone.) After making the adjustment, paint the screw with G103.

Table 1

Maximum Aperture	Depth from Flange (mm)	Switching point	Switching position (mm)
5.6	5.70 ± 0.05		
4.5	6.00 ± 0.05	4.5 → 5.6	5.85 ± 0.1
4.0	6.30 ± 0.05	4.0 → 4.5	6.15 ± 0.1
3.5	6.57 ± 0.05	3.5 → 4.0	6.34 ± 0.085
2.8	6.90 ± 0.05	2.8 → 3.5	6.74 ± 0.115
2.5	7.15 ± 0.05	2.5 → 2.8	7.025 ± 0.075
2.0	7.46 ± 0.05	2.0 → 2.5	7.035 ± 0.105
1.8	7.72 ± 0.05	1.8 → 2.0	7.59 ± 0.8
1.4	8.10 ± 0.05	1.4 → 1.8	7.91 ± 0.14
1.2	8.38 ± 0.05	1.2 → 1.4	8.24 ± 0.086



Fig. 14

I. DISASSEMBLY/ASSEMBLY

I-8 WINDING AND REWIND

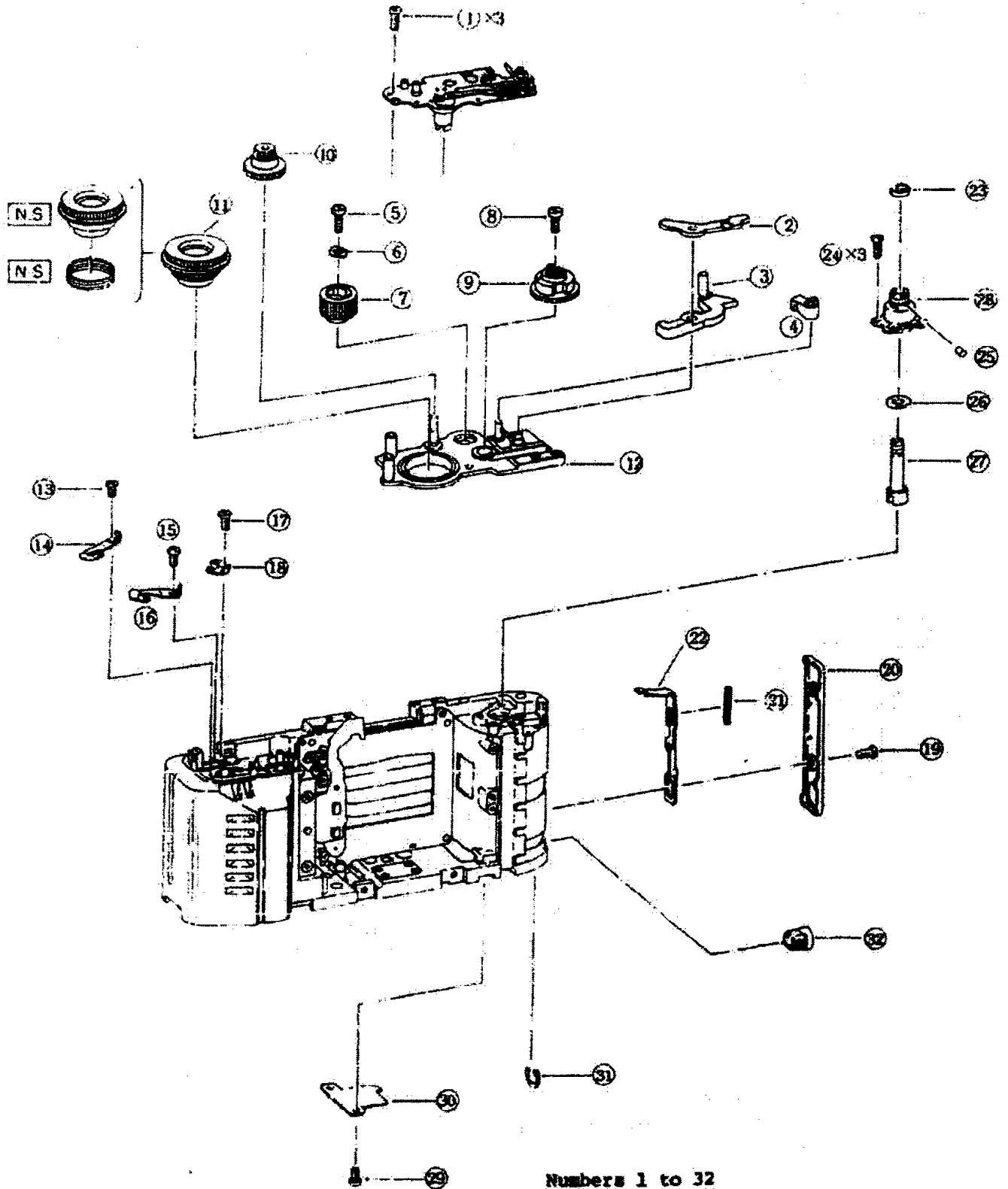

Numbers 1 to 32

I. DISASSEMBLY/ASSEMBLY

I-8 WINDING AND REWIND

Disassembly Notes

1. Sprocket gear (7) and rewind stopper gear (9) can be removed more easily if the screws holding rewind lever (3) and reverse stopper lever (4) are also removed while leaving those parts in place.
2. There normally is no need to remove parts (13) to (18) and (29) to (32).

Assembly Notes

1. Be sure to use screw lock on sprocket stopper screw (5) and the winder stopper screw.
2. The types of grease to be applied to the gear spindles and other mechanisms are described in the "Chemicals Required" section.
3. When installing the gears, be careful to avoid bending the leaf spring on winding base plate (12).
4. Perforation position adjustment
 - o The perforation alignment should be correct when the engraved lines shown in the figure at left are aligned.
 - o The engraved lines will be aligned once for each three revolutions of the sprocket (because the sprocket has six teeth).
 - o For winding, release the takeup stopper lever and turn the winding stopper gear screw with a screwdriver.
 - o Turn the driver slowly, being careful to avoid possible breakage of teeth due to misalignment of the takeup gear on the under side.

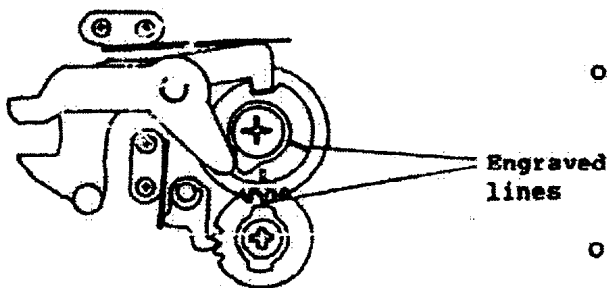

Fig. 15

Note: Numbers in parentheses in the text correspond to circled numbers on the facing page. Disassemble in normal order and reassemble in reverse order.

I. DISASSEMBLY/ASSEMBLY
I-8 WINDING AND REWIND

2. Spool Torque Adjustment

Standard: 200-280 gcm

Adjustment Procedure

1. Spool torque is adjusted by replacing gear (11) in the exploded drawing on page 22.
2. Measure the torque by connecting the torque gauge spring to the film and winding it by about 20-26 cm. The reading should be between 200 and 280 grams. (The spool diameter will be about 1 cm if 5-6 frames, or 20-26 cm of film, have been taken up.)

I. DISASSEMBLY/ASSEMBLY

I-8 WINDING AND REWIND

Rewind crank spindle (see the exploded drawing on page 22 for disassembly.)

Assembly and Adjustment Notes

1. Assemble the rewind crank spindle as shown in Figure A below.
2. The back cover should catch when it has been closed to within 0.3 mm; since this is determined by the precision of the components, replace the back cover or release claw as necessary.

o Washer A in the figure should be positioned below the release claw.

o Be sure that the screws are properly tightened when installing the decorative side plate (release claw cover).

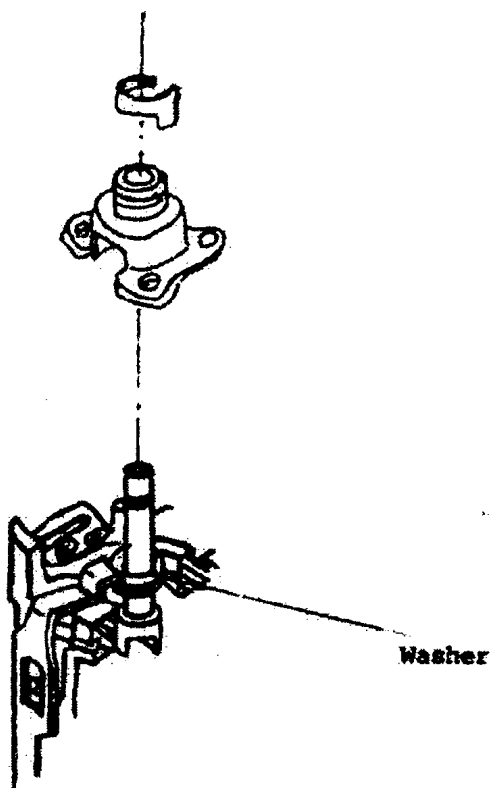
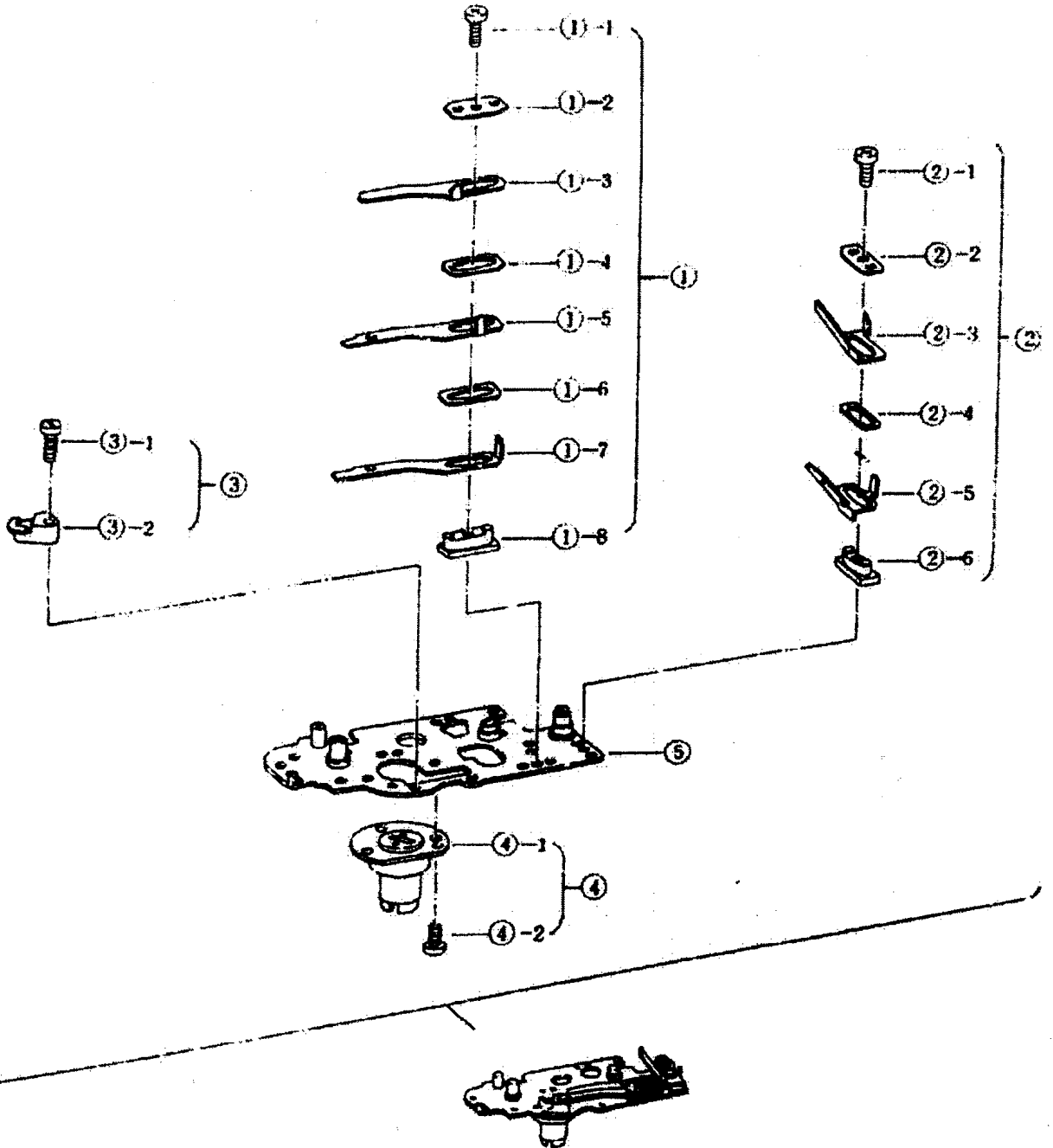

Fig. A

I. DISASSEMBLY/ASSEMBLY

I-9 UPPER WINDING BASE PLATE PARTS



I. DISASSEMBLY/ASSEMBLY

I-9 UPPER WINDING BASEPLATE PARTS

Disassembly Notes

1. Normally, it is not necessary to remove part (3) (the lead wire retainer).

Assembly and Adjustment Notes

1. Parts (2) are switches 4-1 and 4-2; during assembly, ensure that it does not come in contact with parts (2)-3 or (2)-5 (see page 40 for adjustment procedures).
2. Push main switch 1 with your finger and confirm that it does not come in contact with motor holder (4) or upper base plate 1. (Since the main switch gap is determined by the precision of the components, it only needs to be checked.)

Note: Main switch operating range

1. Ensure that SW1 is not on when the release button is 0.1 mm from its seat.
2. The release button should protrude by 0.3 ± 0.2 mm.
3. SW1 should go on when the release button is depressed by 0.3 ± 0.2 mm.
4. SW2 should go on when the release button is pressed by 0.6 ± 0.2 mm. (However, the difference between the points at which SW1 and SW2 go on must be at least 0.2 mm.)
5. Finger pressure:

1st stroke - Display should go on at a pressure of 80 ± 25 grams.

Second stroke - First release should go on at a pressure of 350 ± 70 grams.

Note: Numbers in parentheses in the text correspond to circled numbers on the facing page. Disassemble in normal order and reassemble in reverse order.

I. DISASSEMBLY/ASSEMBLY

I-9 UPPER WINDING BASEPLATE PARTS

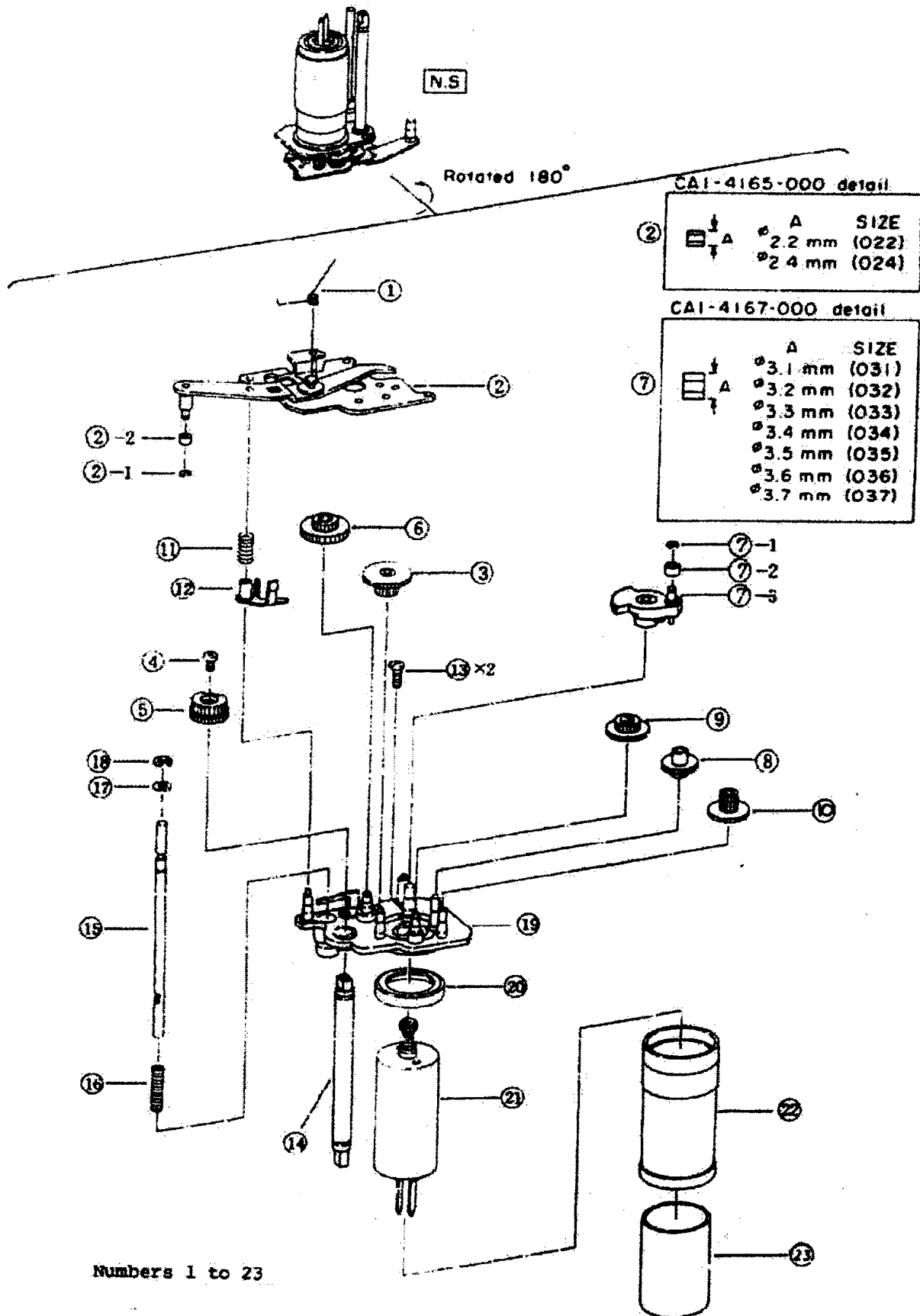

I. DISASSEMBLY/ASSEMBLY

I-10 LOWER WINDING BASEPLATE PARTS

1. Lower winding baseplate adjustment (when the lower winding baseplate unit is installed in the body; see the exploded drawing on page 28).
 - o Lower winding base plate-(2)-2 is soldered to lower winding baseplate-1-(19) at two points.
 - o Remove the three screws marked (4) in the exploded drawing on page 32 and lightly lift lower winding baseplate-(2)-2 with a screwdriver to break the soldered joints.
 - o It is not necessary to resolder lower winding baseplate-(2)-2 to plate-(1)-17 during assembly after adjustment because it is fastened with screws.

Adjustment Procedure

After removing gear (1), rearrange the gears so that they are as shown in the figure at left.

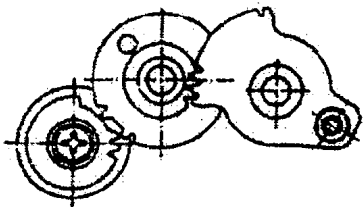

Fig. 16

Note: Numbers in parentheses in the text correspond to circled numbers on the facing page. Disassemble in normal order and reassemble in reverse order.

I. DISASSEMBLY/ASSEMBLY

I-10 LOWER WINDING BASEPLATE PARTS

2. Overcharge Adjustment

Standard: 0.9F - 1.2F

0.9 F ~ 1.2 F

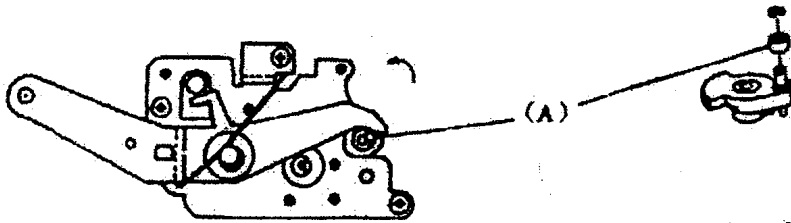

Fig. 17

Fig. 18

Adjustment Procedure

[See page 40 for adjustment of switches 4-1 and 4-2]

1. Attached an FD50 mm F1.4 tool standard lens.
2. Remove the winder stopper lever and turn the winder stopper gear clockwise, then read the f/number of the tool lens at the point just prior to the direction of movement of the lever is reversed.

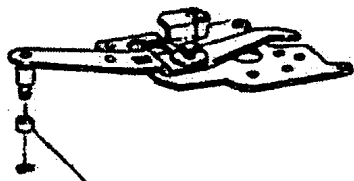

Fig. 19

(B)

(Lower takeup base plate-2)

Adjust by replacing sector gear roller A, shown in the figure above.

I. DISASSEMBLY/ASSEMBLY

I-10 LOWER WINDING BASEPLATE PARTS

Motor (spool) Replacement

(See page 32 for disassembly)

Disassembly/Assembly Notes

1. Spool (22) is welded to spindle-bearing (20), so disassembly is not possible.
 2. During assembly, be sure to affix parts (18) and (20) with cyanobond glue.
 3. Apply alcohol to the spool rubber to make it easier to install.
-
1. When replacing the motor, be sure to replace the spool as described in the notes above.
 2. Contamination of the spool rubber with grease, etc. can prevent the film from being advanced properly; be careful to avoid touching it with your fingers.

Note: Numbers in parentheses in the text correspond to circled numbers on the page 28. Disassemble in normal order and reassemble in reverse order.

I. DISASSEMBLY/ASSEMBLY

I-11 SHUTTER UNIT REMOVAL (AL COVER AND SPROCKET)

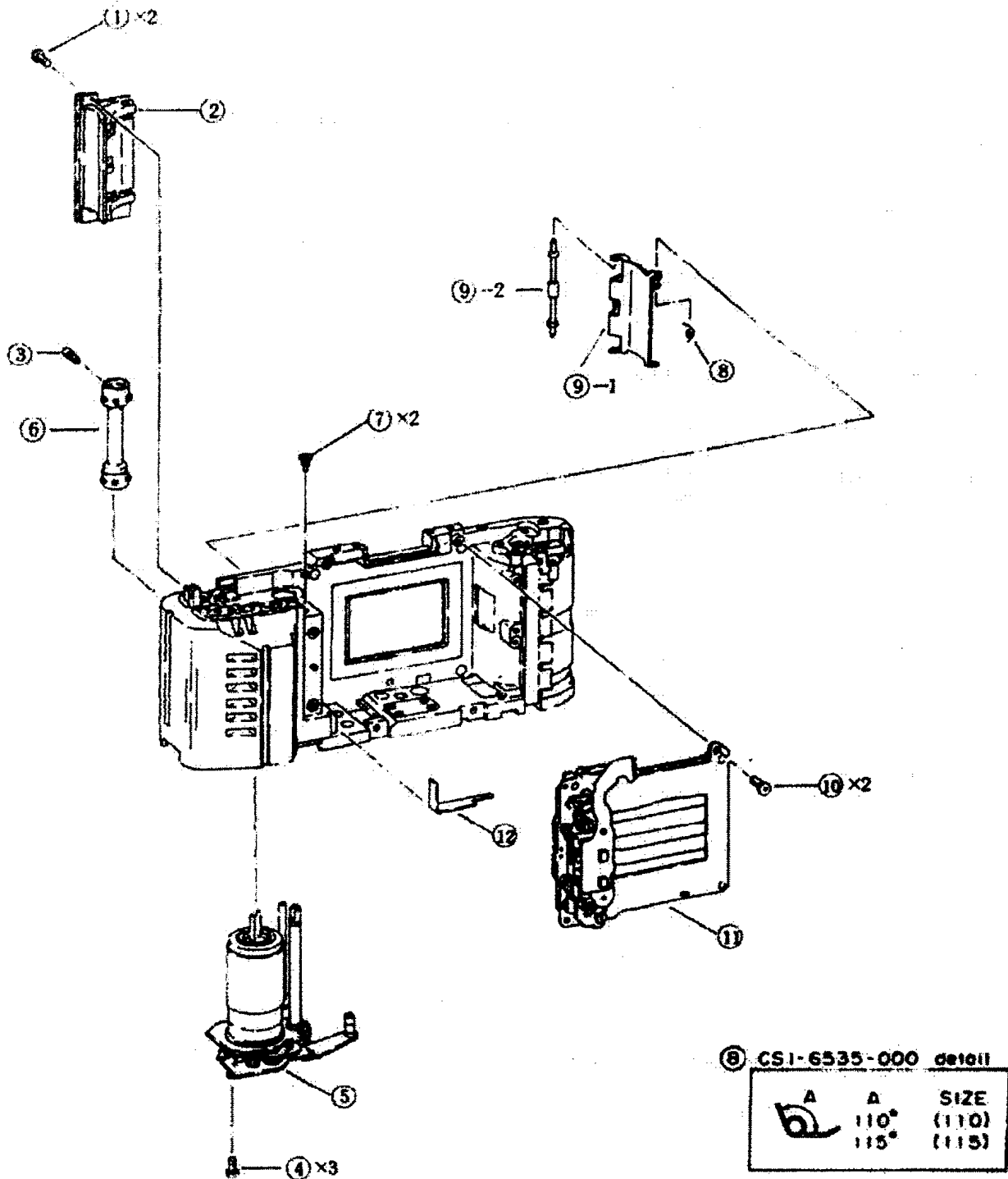

I. DISASSEMBLY/ASSEMBLY

I-11 SHUTTER UNIT REMOVAL

Shutter Unit Removal and Installation

Disassembly Notes

1. Remove the shutter unit by unscrewing screw (10) (two each).
2. Removal of parts (1) to (9) is not necessary in order to remove the shutter.
3. Part (12) is ordinarily not removed (except when replacing the body).

Assembly Notes

1. Set the shutter light shield as indicated by the arrows in the figure (in the direction of the body aperture) and fix it in place with diabond.
2. After installing the shutter, be sure to push the 1st curtain armature to where it is in the open position (this is to protect the shutter and facilitate front panel installation.)
3. Be sure to inspect as described in the shutter work standards before installing the shutter.

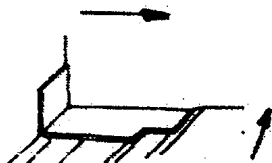

Fig. 20

Note: Numbers in parentheses in the text correspond to circled numbers on the facing page. Disassemble in normal order and reassemble in reverse order.

I. DISASSEMBLY/ASSEMBLY

I-11 SHUTTER UNIT REMOVAL (AL COVER AND SPROCKET)

Removing the sprocket and AL cover

Disassembly Notes

(See page 32 for disassembly.)

1. Remove the sprocket clutch screw before removing the upper winding baseplate.
2. Since the welded part of the lower winding baseplate unit comes loose easily, take care when removing it.

Assembly and Adjustment Notes

1. During installation, be sure to attach the sprocket clutch screw to the beveled part of the sprocket spindle.
2. Install the AL cover as shown in the figure.
3. The AL cover operating spring should exert a pull of 60-90 gr-cm when the cover separates from the spool cover and should have a bend of 115°.
4. Ensure that the end of the spring is fully inserted into the groove in the body.

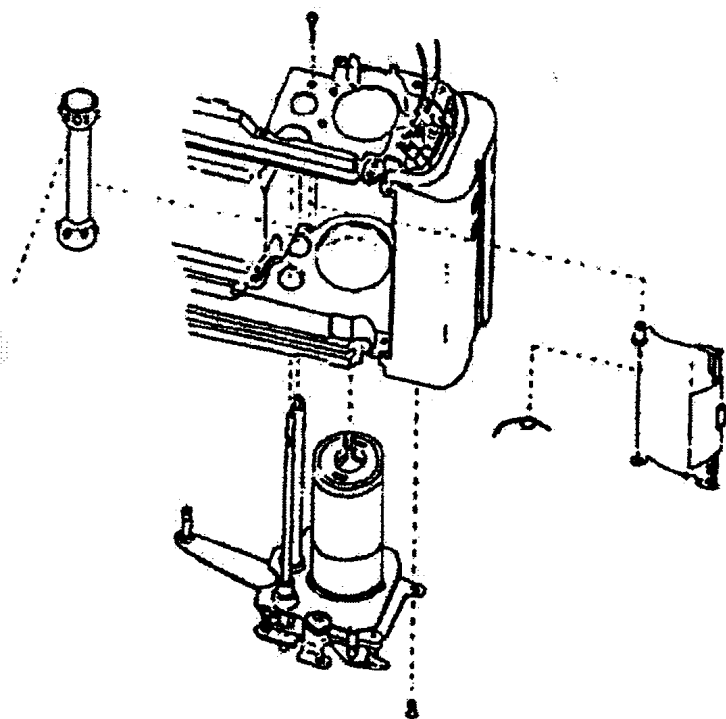

Fig. 21

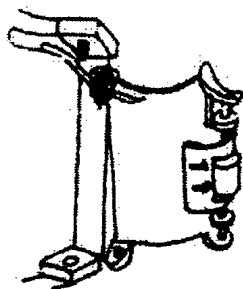

Fig. 22

II. ADJUSTMENT

II-1 FRAME COUNTER ADJUSTMENT

Frame Counter Gear Installation (adjustment)

1. Apply PL-015 grease (CY9-08073-000) to the part of the Frame counter gear shown in Figure 23.
2. After confirming positioning of the drive spindle (Figure 26) with the spring and collar set, twist the collar for two turns in the counter-clockwise direction (so that it floats lightly at the drive spindle) and fasten it. (Ensure that the collar is tensioned.)



Fig. 23

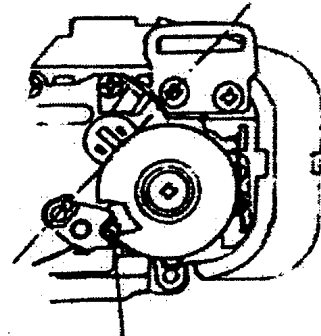

Drive spindle

Fig. 25

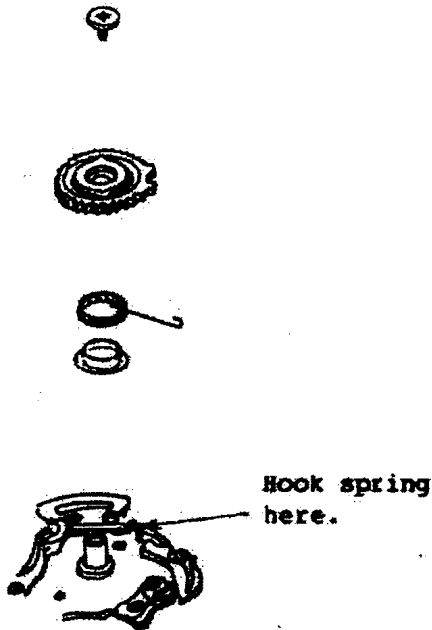

Fig. 24

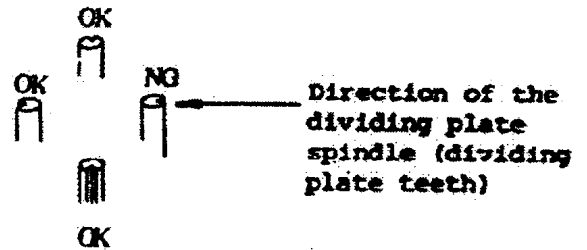

Fig. 26

3. Confirm that the gap between the drive gear and film counter gear is as shown in Figure 27.

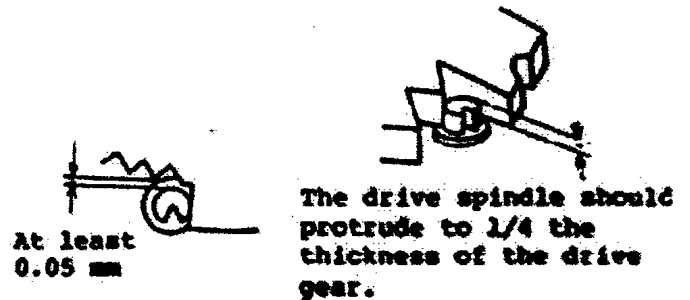

Fig. 27

II. ADJUSTMENT

II-1 FRAME COUNTER ADJUSTMENT

4. Confirm that the first frame positioning switch (CNT or SW13) operates smoothly when the frame counter is moved.

Note: The CNT switch of early production models is as shown in Figure 28A. Later models have an eccentric adjustment in Figures 28B and 28C.

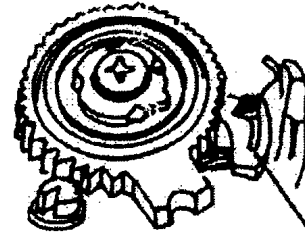

Fig. 28

CNT回轉体

Fig. 28 First frame positioning switch (CNT or SW-13) (Early type)



Fig. 28 b

- 4.1 Close the back cover and set the frame counter drive spindle as at the fourth tooth as shown in Figure 28B. (The fourth tooth is the "1" position on the frame counter dial.)



Fig. 28 c

- 4.2 Adjust so the distance between the SW-13 contact and the eccentric is as shown in Figure 28C with the head of the eccentric as shown by the solid instead of the dotted line.

Note: The adjustment should be as shown. The eccentric can be adjusted so that physical interference with other parts makes proper operation impossible.

5. Apply G103 glue to the part of the gear shown in the figure and stick it to the index. (Use the notches inside the index to align the cover index position.)

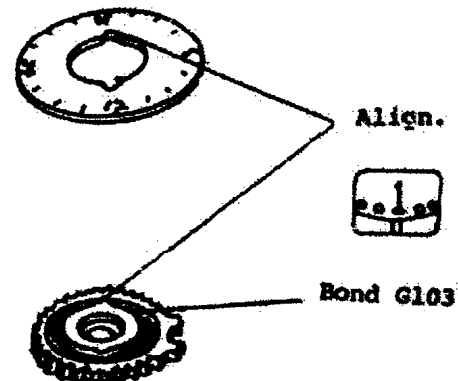

Fig. 29

II. ADJUSTMENT

II-1 FRAME COUNTER ADJUSTMENT

Frame counters drive gear adjustment

- o Put the camera in the wound condition, apply PL-015 grease to the return lever as shown in Figure 30, then adjust the mesh of the idle gear teeth so that the V-groove in the drive gear is positioned as shown in Figures 25 and 26 on page 35; lock the setting with a retainer.
- o When installing the retainer after installing the return lever, position it as shown in Figures 32 and 33; ensure that thrust play in the gears is less than 0.05 mm.



Fig. 30



Fig. 31

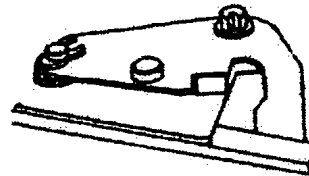

Fig. 32

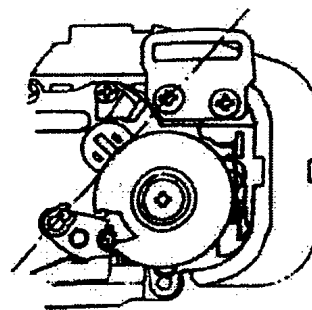

Fig. 33

II. ADJUSTMENT

II-2 SHUTTER*

Shutter Adjustment

Standards:

	Full Aperture	Shutter Tester
1st curtain speed:	8 ± 0.3 ms	7.5 ± 0.3 ms
2nd curtain speed:	8 ± 0.3 ms	7.5 ± 0.3 ms

Shutter speed (1/1000): 0.793-1.202 ms

Exposure variation: 0.3 EV or less
(Frame to frame)

Exposure variation: Start - $+0.3$ EV
(Across the frame) End - $+0.3$ EV

X (flash) A value: 0.5 ms or more

Adjustment procedure

1. Both the first and second curtain speeds can be adjusted before the shutter unit is installed in the camera, but only the first curtain speed can be adjusted afterwards; this is done from the underside of the body.
2. Since the camera is used only for program exposure, shutter adjustment is made only for the 1/1000 sec. setting.
3. The shutter speed is always 1/1000 sec. when the back cover is open (because the first frame positioning switch (CNT) (SW13) is grounded).
4. The shutter speed is adjusted by turning VR2 to the right or left.

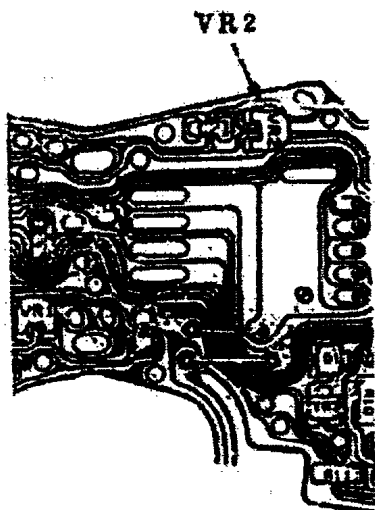

Fig. 34

* : Assembly and disassembly of the shutter is explained in the separate EMAS Repair Guide on this microfiche.

II. ADJUSTMENT

II-3 AUTOMATIC EXPOSURE (AE) ADJUSTMENT

(Level adjustment with VR1)

- o AE is adjusted only by varying the level.

Standard: ± 0.4 EV at all check points

Adjustment

Check EV9, EV12, and EV15 at K=12.5.

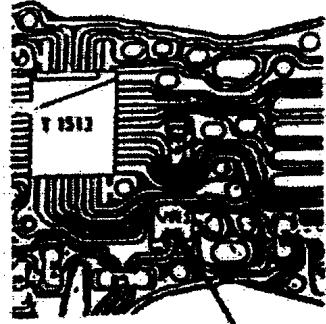

Level adjustment

Fig. 38

- o Mount a tool standard lens (FD50mm, f1.4) on the camera and set it to the A mark.
- o Set the film speed dial to ASA100. (Align the engraved line on the ASA armature unit with the tip of the lock spring.)
- o Confirm that the film counter is on "1" or higher. (Unsolder the SW-13 lead wire.) A kludge made from a portion of the back cover should be used to keep the frame counter engaged.
- o Check the level with a EV Tester; the level at all check points should be within ± 0.4 EV.
- o When only a light source is available, check the level at EV10 and EV13 using a tool (AE precision) standard lens. These levels correspond to f2.8 and f5.6.
- o Since the gain adjustment for the T50 is made during assembly, only the level need be adjusted unless IC-2 is replaced (IC Replacement, Section II-6).

II. ADJUSTMENT

II-4 SW4-1 AND SW4-2 ADJUSTMENT

Adjustment of SW4-1 and SW4-2

Standard:

Connecting Lever reverse position	SW4-1 ON	SW4-2 ON
335°	335°-348°	348°-355°

(Ensure that there is no overlap.)

Armature pressure: 30 \pm 10 grams

Adjustment procedure

Connect the + probe of a multimeter to the SW4-1 terminal shown in Figure 39 and contact the - probe to the upper winding baseplate; release the winder stopper lever (Figure 41), then use a screwdriver to turn the gear screw shown in Figure 40 slowly clockwise until a "click" is heard. The position at which the click is heard is the reverse point; this should be encountered prior to the 340° position shown in Figure 40. After determining the reverse point, turn the eccentric shown in Figure 39 to where SW4-1 goes on.

- o The SW4-2 eccentric is on the same axis, so no separate adjustment is required.
- o SW4-1 and SW4-2 are used as count switches, as well as for stopping the motor; therefore, check the contact pressure and cleanliness.

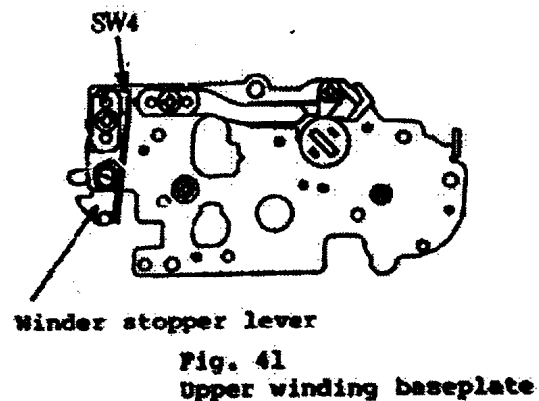
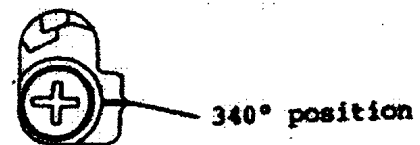
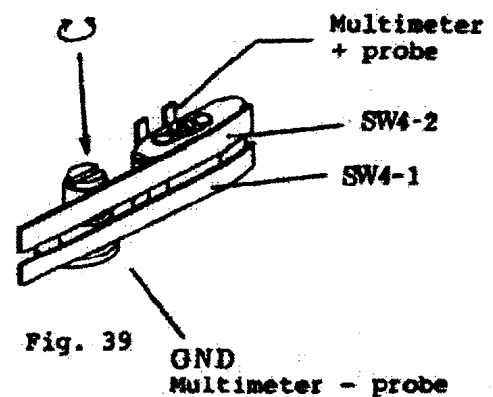

II. ADJUSTMENT

II-4 SW4-1 AND SW4-2 ADJUSTMENT

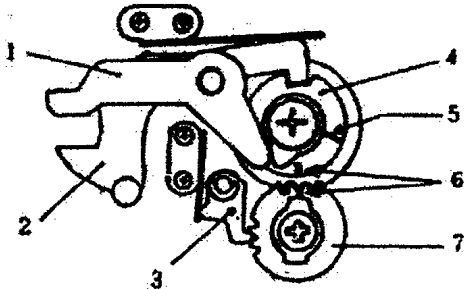

Fig. 42

In winding completed condition

1. Mirror release lever
2. Winder stopper lever
3. Reverse stopper lever
4. Winder stopper gear
5. Engraved line for adjustment of SW4
6. Engraved lines for perforation adjustment

Reverse position

The sector gear (2. in Figure 43) presses the connecting lever (1. in Figure 43) in the direction indicated by the arrows in Figure 43; after the winder stopper gear (4. in Figure 42) has turned 335°, the sector gear is released to turn and the connecting lever is returned by the spring (4. in Figure 43), causing a clicking sound.

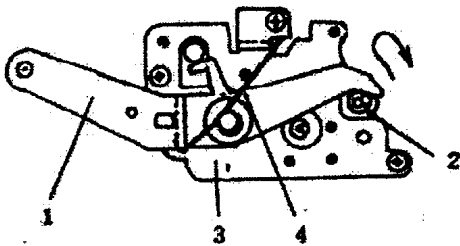

Fig. 43

1. Connecting lever
2. Sector gear
3. Lower winding base plate
4. Spring

- o The reason for adjusting SW4-1 as described is that the motor will go off, preventing the mirror box mechanism from being set, if SW4-1 goes on before the reverse point is reached.

II. ADJUSTMENT

II-5 REWIND SWITCH

(SW12) adjustment

The rewind switch (SW12) is an extremely important switch which controls release of film tension after winding is completed, clearing of the mirror up condition, and other sprocket-related operations.

Setting positions

1. Maximum rewind button stroke: 3 mm
2. Rewind button lock: 2.5 mm Simultaneous
3. SW12 on: 2.5 mm

Adjustment

- o Adjust by bending the SW12 contact. Confirm that the switch goes on when the clicking sound accompanying locking of the release button occurs as it is pushed back up.
- o A feature of the T50 is that the rewind button lock is released twice, once by the front panel charge lever and once by the winding gear.

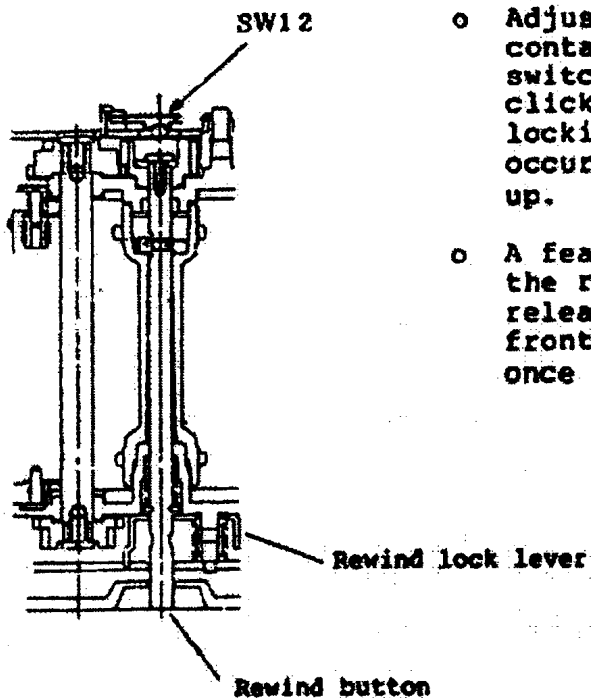

Fig. 44

II. ADJUSTMENT

II-6 POST IC REPLACEMENT ADJUSTMENT

Reference voltage (VC) measurement

1. Standard: 1.3V \pm 50mV
2. Measurement
 - o Connect a 3V power source to the camera.
 - o Connect a digital multimeter between the VC check bit of IC-1 and ground.
 - o Set SW1 to ON and measure the voltage.

Gain adjustment (R4)

1. Standard:
2. Adjustment
 - o Disconnect the temperature compensating resistor (R5) and measure the resistance: X ohms

$$R4 = \frac{VC}{0.4272} \times X \text{ ohms}$$

- o Install a resistor which provides the calculated resistance.

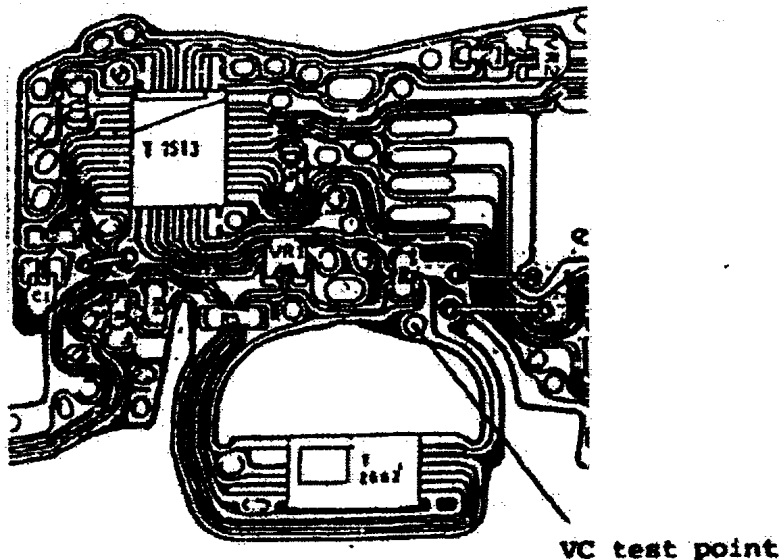

Fig. 45

II. ADJUSTMENT

II-6 POST IC REPLACEMENT ADJUSTMENT

Offset adjustment

- o This adjustment is required when replacing IC-1 (the metering IC).

Standard: Pin 10 - pin 11
voltage = +30 to -10 mV

Offset voltage measurement

- o Unsolder one side of resistor R5.
- o Short pins 9 and 11 of IC-1.
- o Measure V1 (the voltage between pin 10 (TP) and GND).
- o Measure V2 (the voltage between pin 11 (MOS out) and (CTND)
- o No adjustment is required if V1-V2 is between +30 and -10 mV; otherwise, adjust as described below.
- o If the result was between +30 and -10 mV, remove the short between IC-1 pins 9 and 11 and reconnect RTC.
- o Apply Peligan F (CY9-8055-000) to the pins of IC-1.

Adjustment procedure

- o Disconnect the NULL resistor (R6) and replace it with a variable resistor of about 100K ohms.
- o Turn the variable resistor to where the value of V1-V2 is between +30 and -10 mV.
- o Measure the resistance of the variable resistor at the point where the above condition is satisfied, then install a fixed resistor of equal value as a replacement.
- o Remove the short from between pins 9 and 11 of IC-1.
- o Reconnect R5 and apply Peligan F to the pins of IC-1.

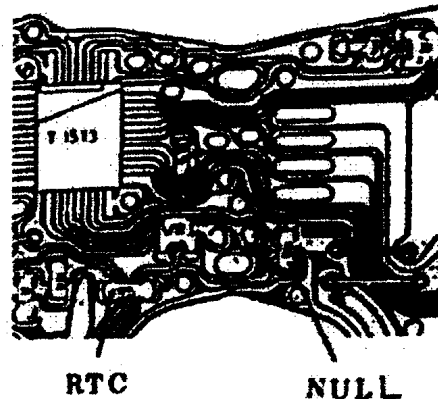

Fig. 46

Apply peligan F to both top and bottom here.

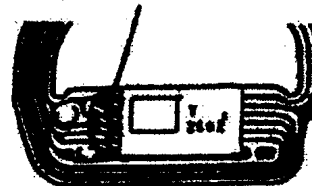

Fig. 47

II. ADJUSTMENT

II-6 POST IC REPLACEMENT ADJUSTMENT

LED current adjustment

Standard: 4.8 mA $\pm 10\%$

Adjustment

- o Mount a lens and set the aperture ring to the A mark.
- o Disconnect the purple lead wire from the LED and connect a multimeter (mA).
- o Disconnect resistor R1 from the flexible PC board and solder a variable resistor of about 50K ohms in its place.
- o Turn the variable resistor to where the multimeter reads 4.8 mA $\pm 10\%$ when SW1 is on.
- o Measure the resistance of the variable resistor at the point where the indicated reading was obtained, then replace it with a fixed resistor of equivalent value.

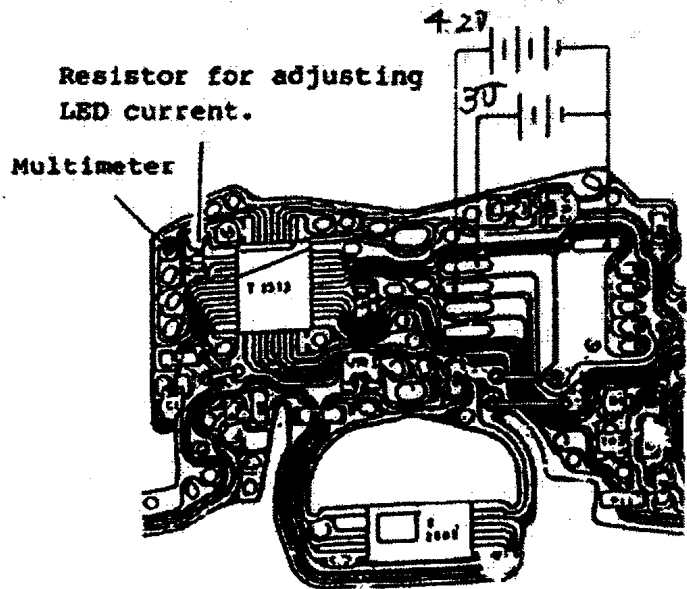

Fig. 48

Oscillator (OSC) Adjustment

Standard: Self-timer time = 10 \pm 1 second

Check Method:

Set the self timer and measure the time from when the shutter button is pressed until the shutter releases. If it is between 9 and 11 seconds, no adjustment is necessary. If it is not, adjust as follows.

Adjustment:

- o Remove R7 and install a 500 KOhm variable in its place.
- o Adjust the variable until the self-timer time is within tolerance.
- o Remove and read the resistance of the variable resistor.
- o Install a fixed resistor with the measured resistance of the variable resistor.

II. ADJUSTMENT

II-6 POST IC REPLACEMENT ADJUSTMENT

Inhibit voltage adjustment

Standard: 1.95V \pm 50 mV

Adjustment

Disconnect the DC/DC converter and apply 4.2V to the DC/DC line from a regulated power supply when making this adjustment.

- o Disconnect resistor R2 and solder a variable resistor of about 40K ohms in its place.
- o Apply 1.95V \pm 50 mV to VBAT from a regulated power supply.
- o Turn the variable resistor to where VC appears at pin 6 of IC-2.
- o Measure the resistance of the variable resistor and replace R2 with a fixed resistor of equal value.

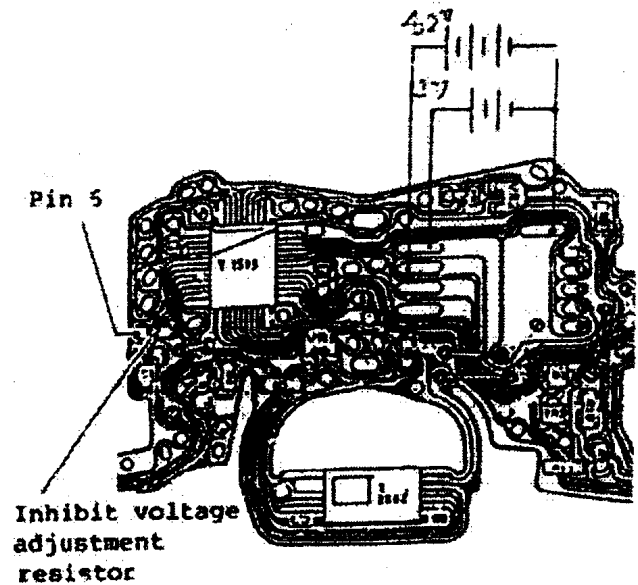

Fig. 49

III. LUBRICANTS, ADHESIVES, ETC.

This section is divided into three parts covering the external parts (1) and internal parts of the body (2) and front panel (3).

For each subsection, the information is listed numerically: 1. Part Name, 2. Lubricant/Bond and, 3. special instructions.

Expendable Order Numbers (Current as of January, 1983)

Bonds;		Lubricants	
Bond G103 (diabond)	CY9-8002-000	PL-15	CY9-8073-000
Aron Alpha	CY9-8007-000	ED-16	CY9-8075-000
		LT-SH	CY9-8033-000
Arontite L (Blue)	CY9-8012-000	Lozoid 1150E/35019	
			CY9-8038-000

1. EXTERNAL PARTS

1-1 Cover parts

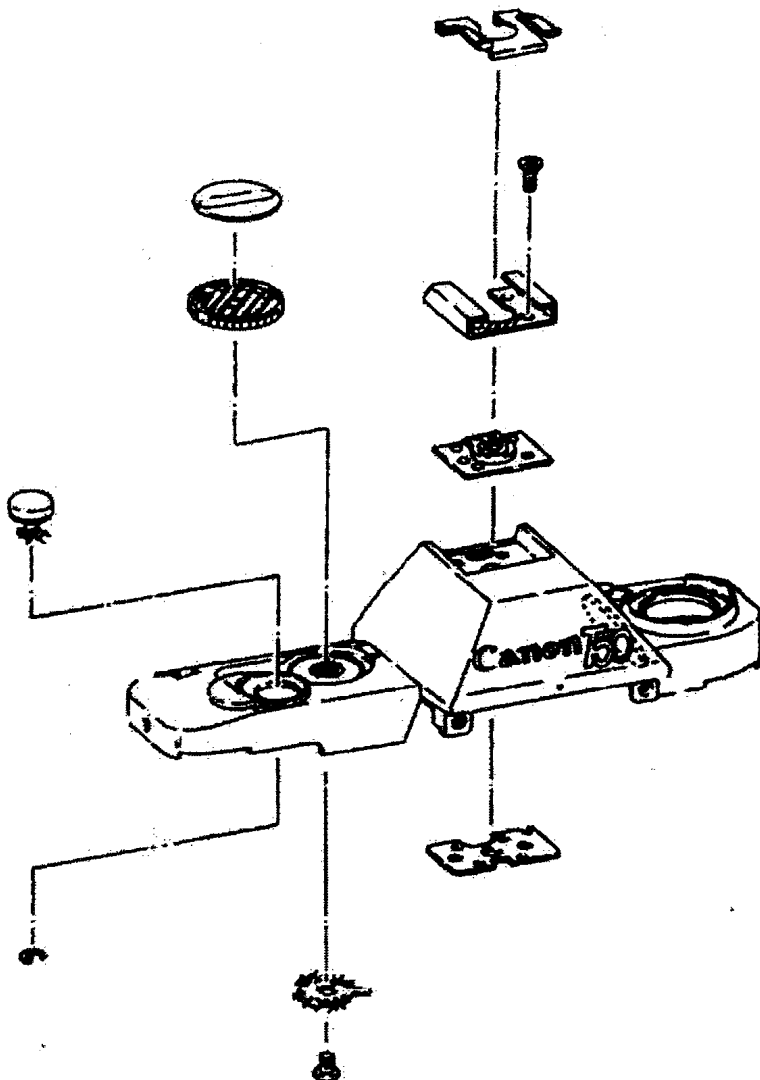

1. Upper cover, release button, lock lever, selector dial, accessory shoe.
2. PL-015, Bond G103, Aron Alpha
3. Paint with PL-15 and apply Bond G103 to the area marked // // // //.

Apply Bond G103 to the beeper.

Apply Aron Alpha to the film counter window.

Be sure that the adhesives do not spread to the outside.

III. LUBRICANTS, ADHESIVES, ETC.

1-2 GRIP RUBBER

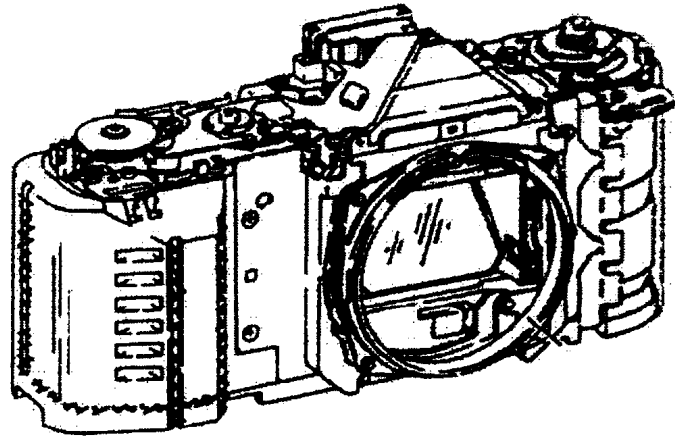
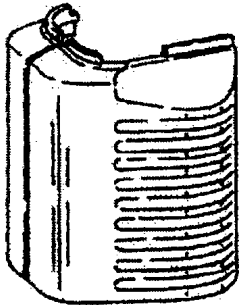

1. Grip rubber
 2. Bond G103
 3. xxxxx
- o Be sure that the adhesive does not spread to the outside.

Note: Numbers in parentheses in the text correspond to circled numbers on the facing page. Disassemble in normal order and reassemble in reverse order.

III. LUBRICANTS, ADHESIVES, ETC.

2. MAIN MECHANISM

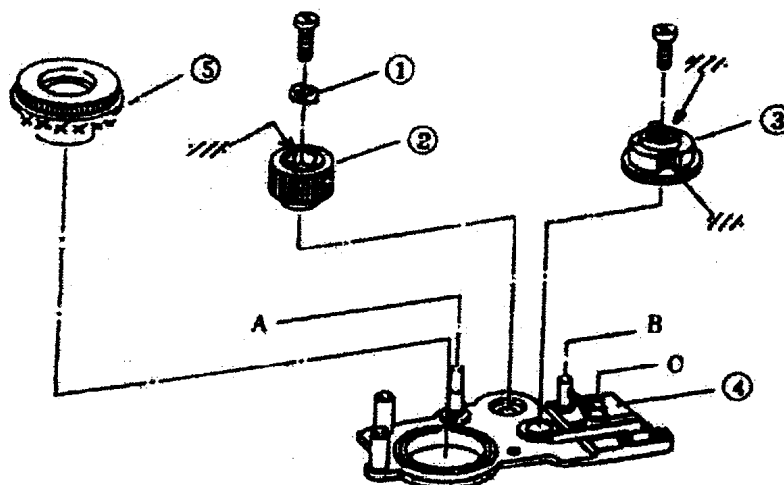

2-1-1 Upper winding baseplate

1. (1) Revolving part of sprocket, (2) sprocket gear, (3) winder stopper gear, (4) Upper winding plate-1.
2. ED-16 LTSH, Aron Tite L.

3. ED-16 (///) and LTSH (xxx) application

Paint the revolving part of the sprocket and the sprocket gear (see figure at left) with ED-16.



Be careful not to apply glue to the area around the stopper screw.



About 0.3 mm
(apply to 3 faces)

- o After repair, apply Aron Tite L (blue), the sprocket gear retaining screw.
- o Also apply Alon Tite L (blue), to the winder stopper gear retaining screw.

III. LUBRICANTS, ADHESIVES, ETC.

2-1-2 Upper winding baseplate-2/sprocket

1. Motor holder
2. LT-SH
3. Apply a 0.2-0.3 mm thickness of LT-SH to at least 1/3 of the circumference of the motor holder, painting the area indicated by xxxx.

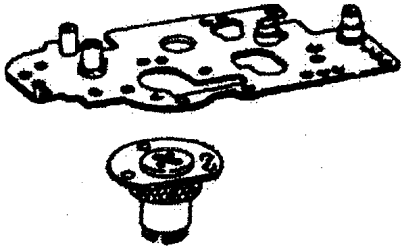

1. Sprocket
2. PL-015
3. Paint the area marked // // // //.

Paint at least 1/3 of the circumference.

Top



About 0.3-0.5 mm

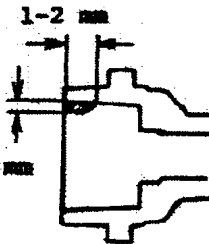

Bottom



About 0.3-0.5 mm

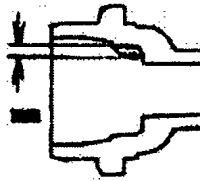

III. LUBRICANTS, ADHESIVES, ETC.

2-1-3 Lower winding baseplate

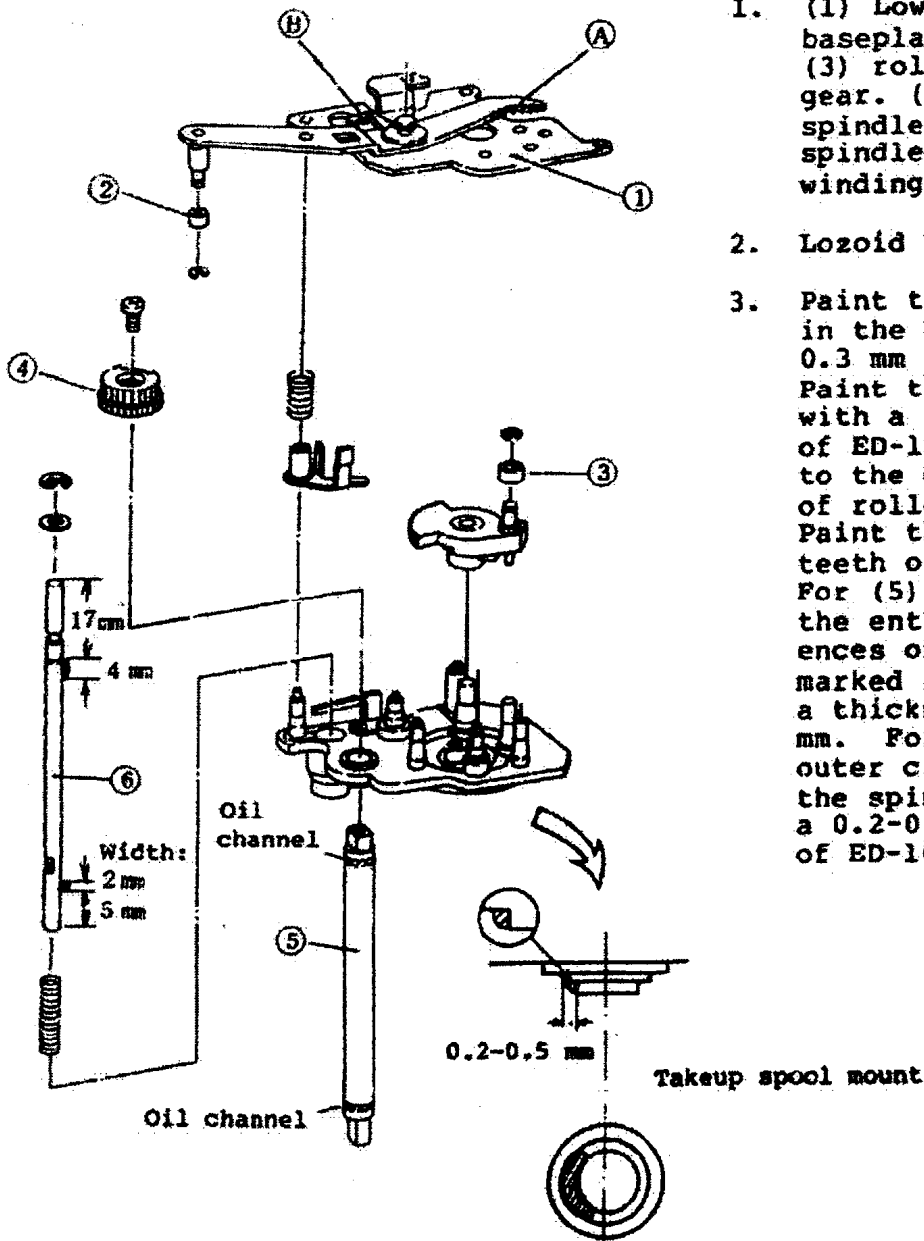

1. (1) Lower winding baseplate-2, (2) roller, (3) roller, (4) winding gear. (5) winding gear spindle, (6) sprocket spindle, (7) lower winding baseplate-1.
2. Lozoid 1150E/35019, ED-16
3. Paint the area marked A in the figure with a 4 x 0.3 mm layer of Lozoid. Paint the area marked B with a 2 x 0.3 mm layer of ED-16. Apply Lozoid to the entire surfaces of rollers (2) and (3). Paint the outside of the teeth of (4) with ED-16. For (5) and (6), paint the entire circumferences of the areas marked in the figure to a thickness of about 0.3 mm. For (7), paint the outer circumference of the spindle bearing with a 0.2-0.3 mm thickness of ED-16.

III, LUBRICANTS, ADHESIVES, ETC.

2-1-4 Spool

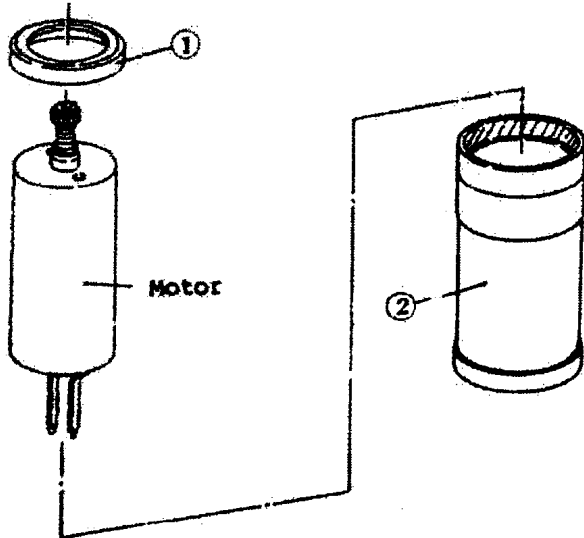

1. (1) Spool spindle bearing, (2) spool
2. Aron Alpha
3. Paint the area marked // with Aron Alpha. (Be careful to avoid application to neighboring areas.)

2-1-5 Rewind Mechanism

1. (1) Rewind fork, (2) release claw
2. PL-015, ED-16
3. Apply 0.2-0.3 mm of PL-015 to the click groove of (1) and paint at least 1/3 of the circumference. Paint (2) with a 0.2-0.3 mm coating of ED-16 as shown in the figure.

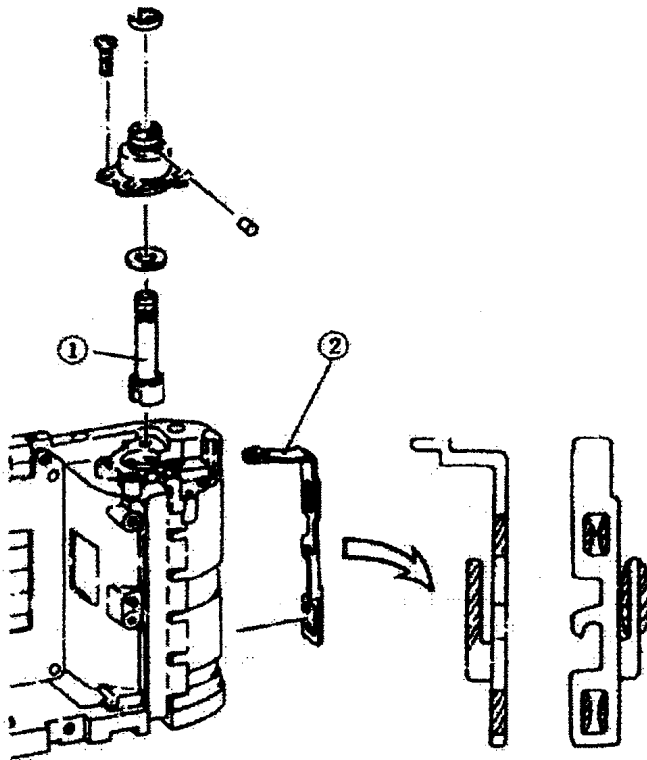

Winder stopper gear

Paint the stopper part with ED-16.

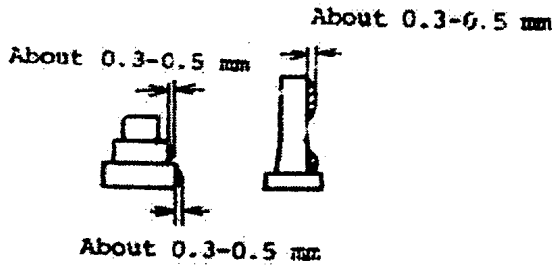
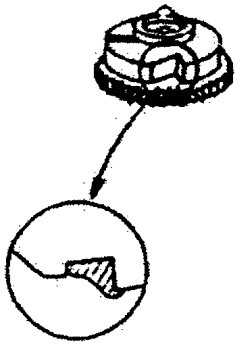

- o As shown in the figure at left, paint at least 1/3 of the circumference of studs A, B, and C of upper winding base plate-1 with a thickness of 0.2-0.3 mm.

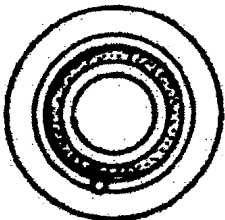
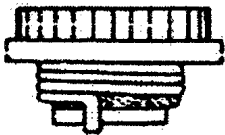

- o Spool gear

Paint the entire circumference of the spool gear with LTSH as shown in the figure at left.

III. LUBRICANTS, ADHESIVES, ETC.

2-1-5 Film Counter

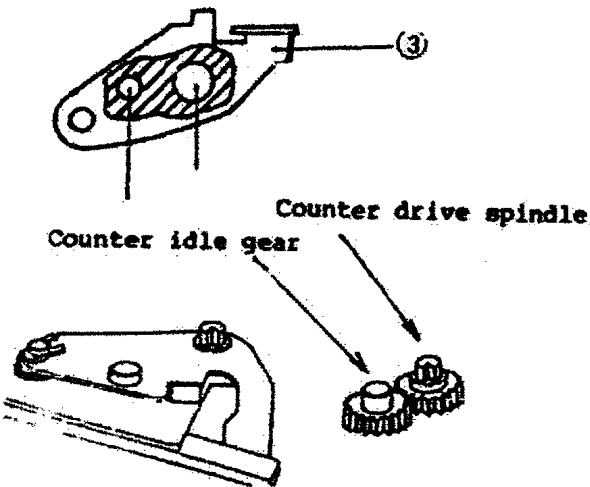
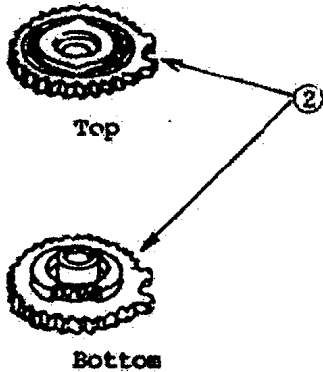
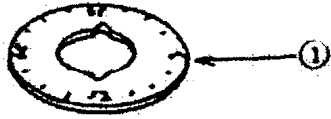

1. (1) Index, (2) Frame Counter Gear, (3) Return level.
 2. Bond G103, PL-015
 3. CY9-8001-000, CY9-8073-000
 4. Paint the area marked xxxx with Bond G103; paint the areas marked xxxx with PL-015.
- o Paint (3) with a 0.2-0.3 mm layer of PL-015 (but be careful to avoid getting PL-015 into the V-groove of the counter drive spindle).

III. LUBRICANTS, ADHESIVES, ETC.

3. FRONT PANEL

3-1 AE Unit

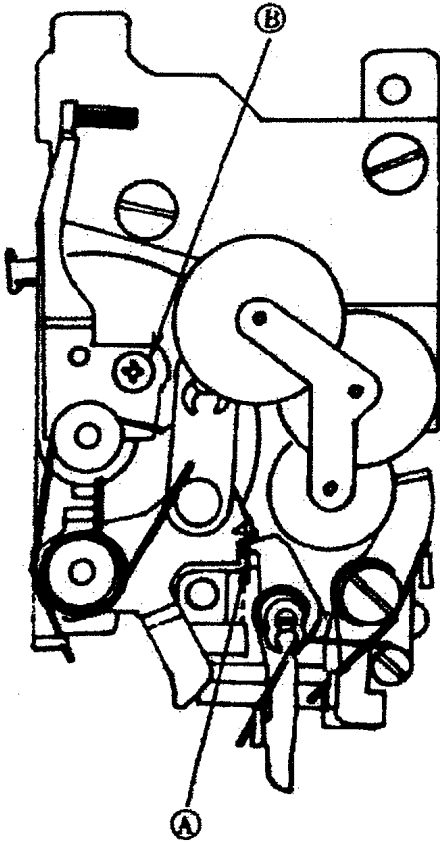

1. AE Unit
2. Bond G103, Lozoid 1150E/35019
3. Paint the area marked A with Lozoid. Paint the head of screw B with G103.

III. LUBRICANTS, ADHESIVES, ETC.

3-2 Mirror Mechanism

1. Mirror Mechanism
2. Lozoid
3. Paint the areas marked A with Lozoid.

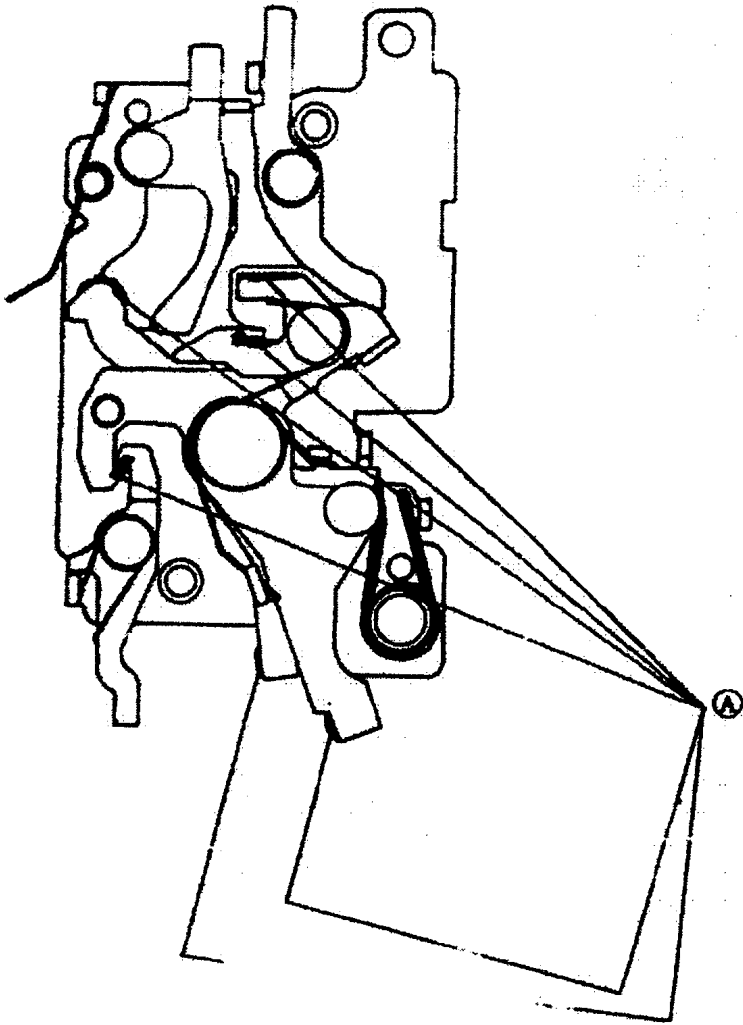

III. LUBRICANTS, ADHESIVES, ETC.

3-3 Automatic diaphragm unit

1. Automatic diaphragm unit
2. Bond G103, Lozoid 1150E/35019
3. Paint the areas marked A with Lozoid; paint the heads of the screws marked B with G103.

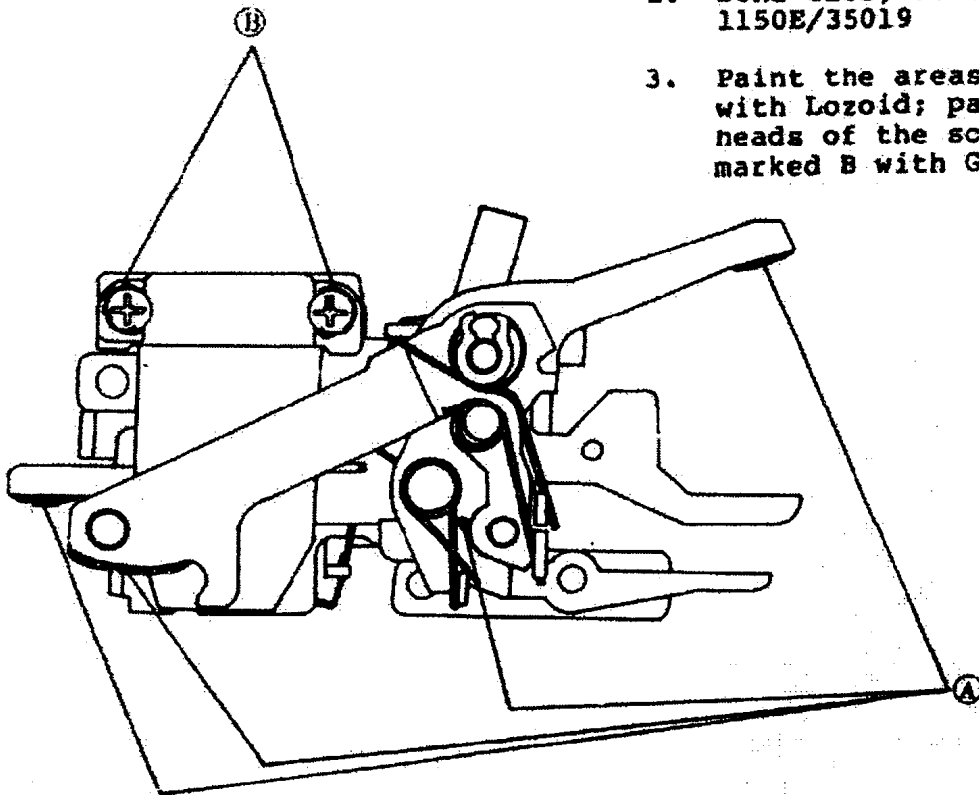

3-4 Maximum Aperture Compensation Pin

1. Full aperture compensation pin
2. Bond G103
3. As shown in figure at left.

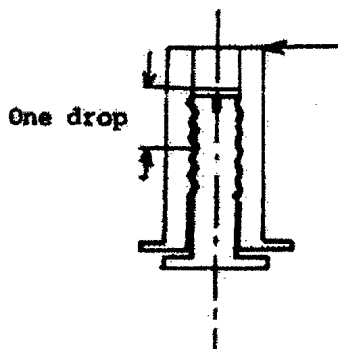

Since this is a reference surface, be careful to avoid getting any G103 on the outside.

IV. OTHER POINTS OF NOTE

Other points of Note

1. Flangeback

(The standards for the flangeback are omitted because they are the same as for other cameras.)

Since the T50 does not have a T or B setting, procedure for holding the shutter open is described below.

1-1 When the camera is fully assembled

Mount a lens and set the aperture ring to the A mark. Place a cap on the lens and cover the eyepiece. Trip the shutter and remove the battery; the shutter will remain open.

2-2 When the camera is disassembled

Using tweezers, forcibly release Mg2 from the bottom of the camera; next, lightly push the first curtain aperture of the shutter unit to open the shutter.

CANON CASE FOR T50

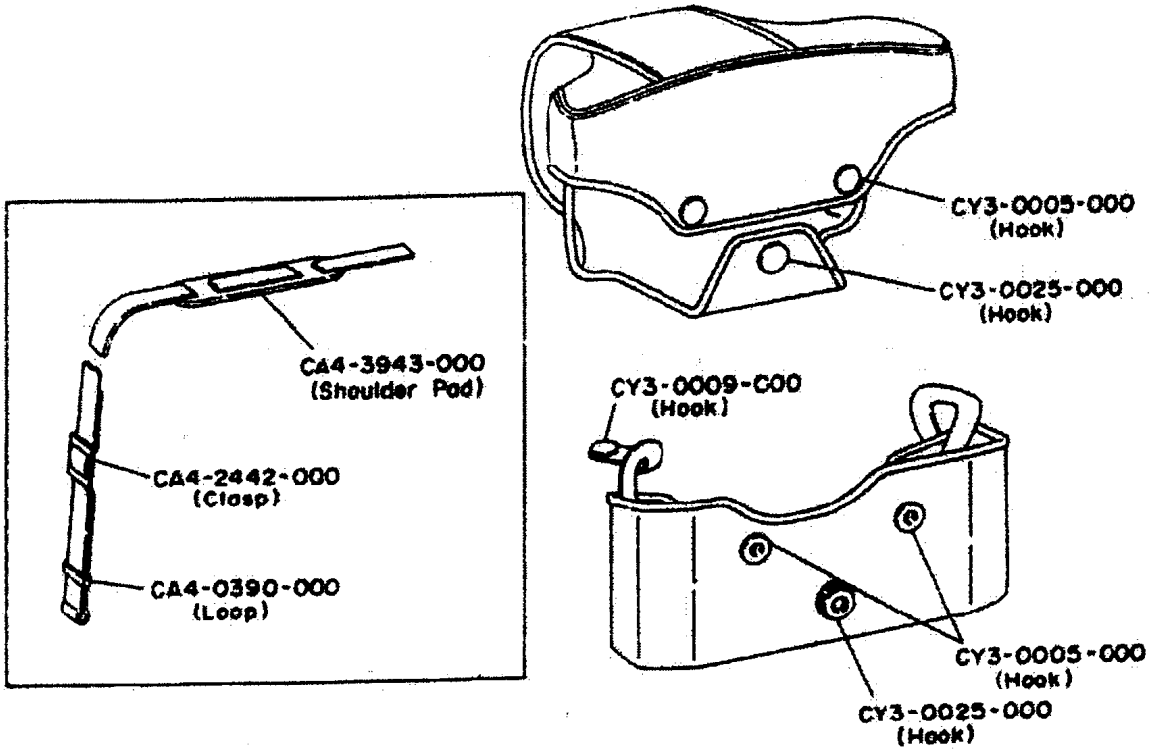

REF. NO. C46-1161,2

CASE PARTS LIST

NEW	PART NO.	CLASS	QTY	DESCRIPTION
	CA4-0390-000	D	1	LOOP
	CA4-2442-000	D	1	CLASP
	CA4-3943-000	D	1	PAD SHOULDER
	CY3-0005-000	D	1	HOOK
	CY3-0009-000	D	1	HOOK
	CY3-0025-000	D	1	HOOK

92

60

2. No VDC Output (DV: Use digital voltmeter)

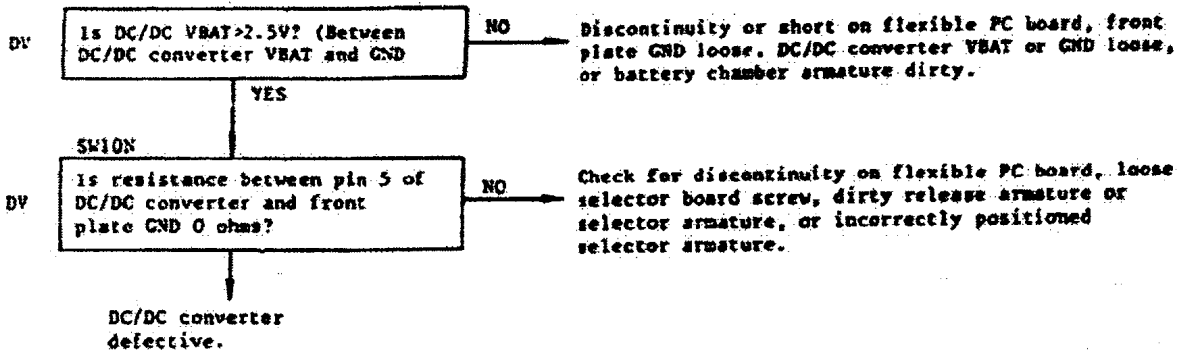

No VC Output

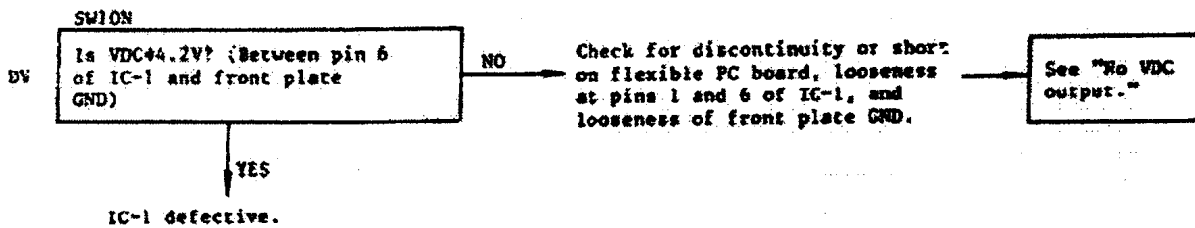

No KVC output

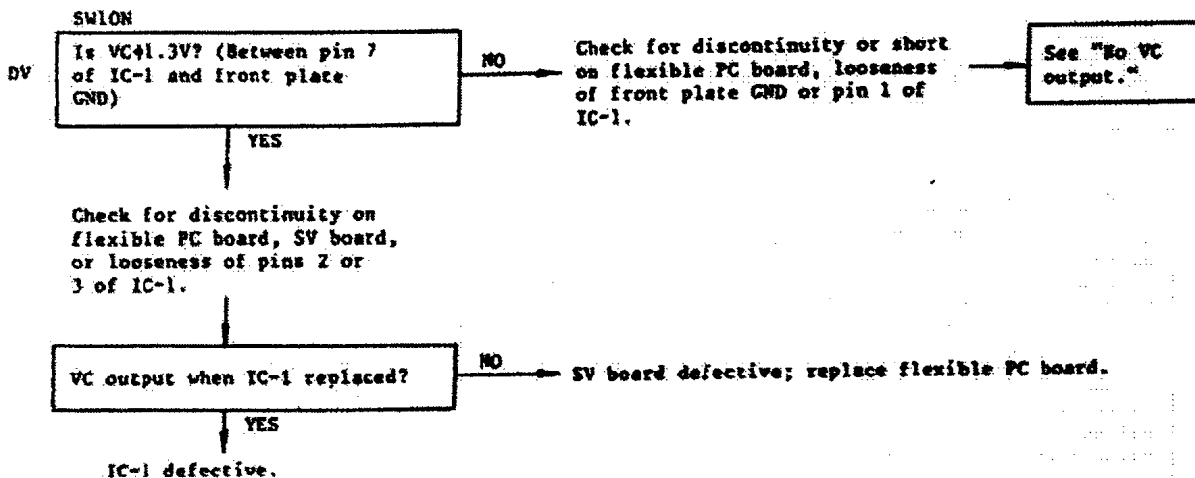

3. Takeup Mechanism Inoperative

(DV: Use digital voltmeter)

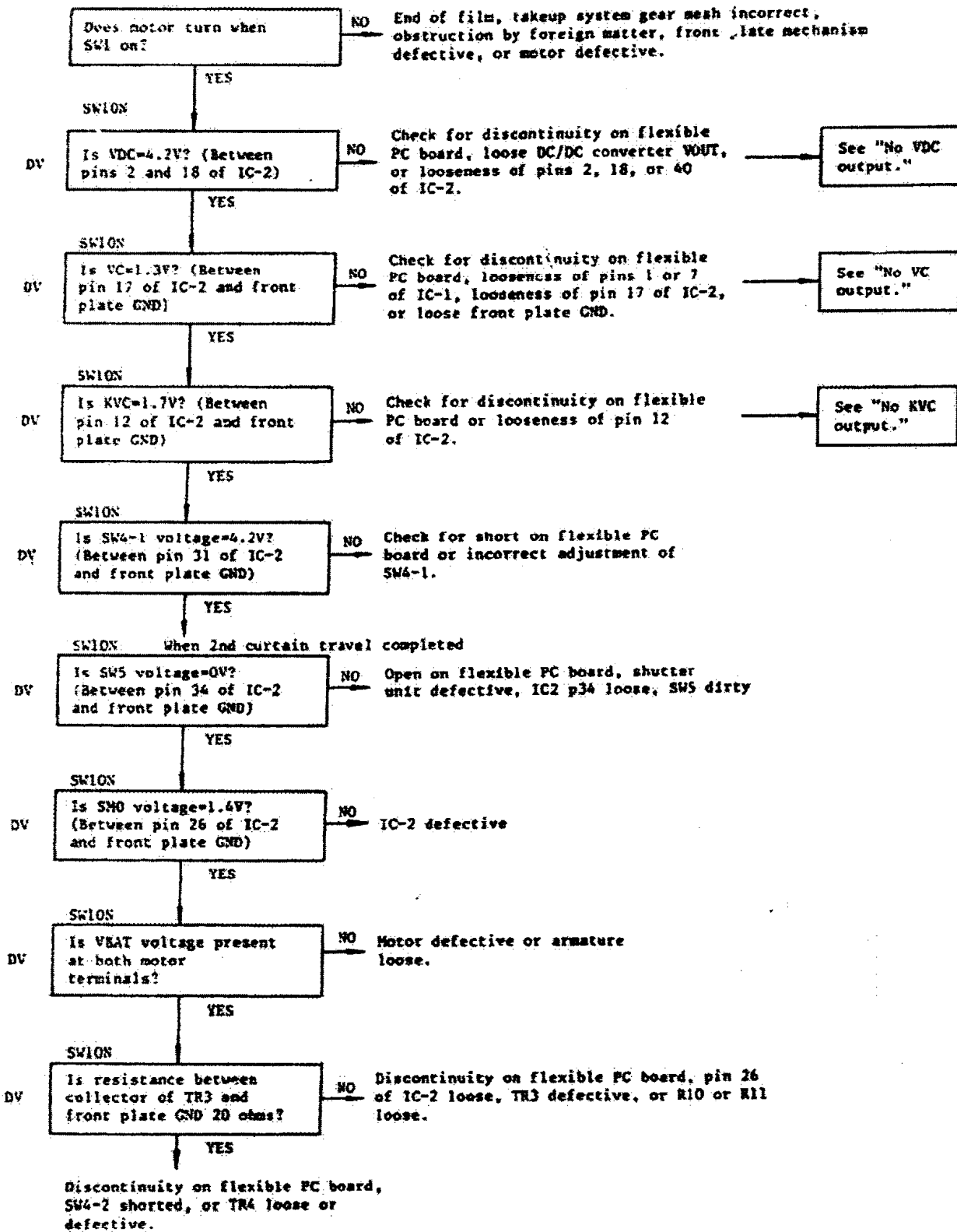

4. 1/1000 Setting Not Adjustable

(DV: Use digital voltmeter)

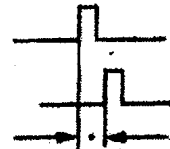
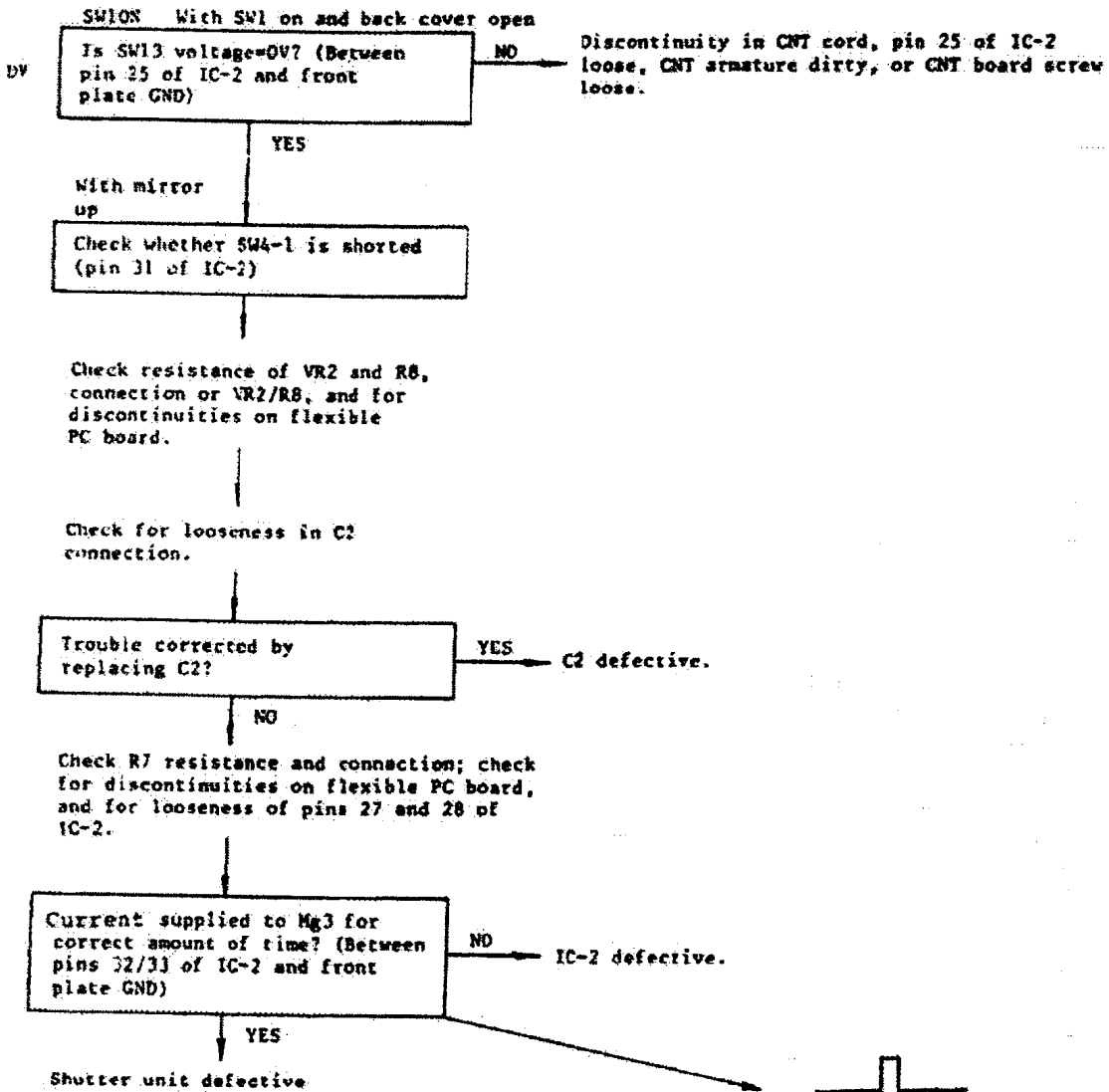

5. 1st Curtain doesn't Travel (SY - Use Synchroscope; DV - Use digital voltmeter)

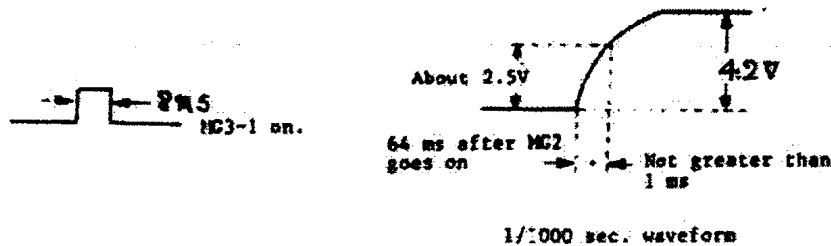
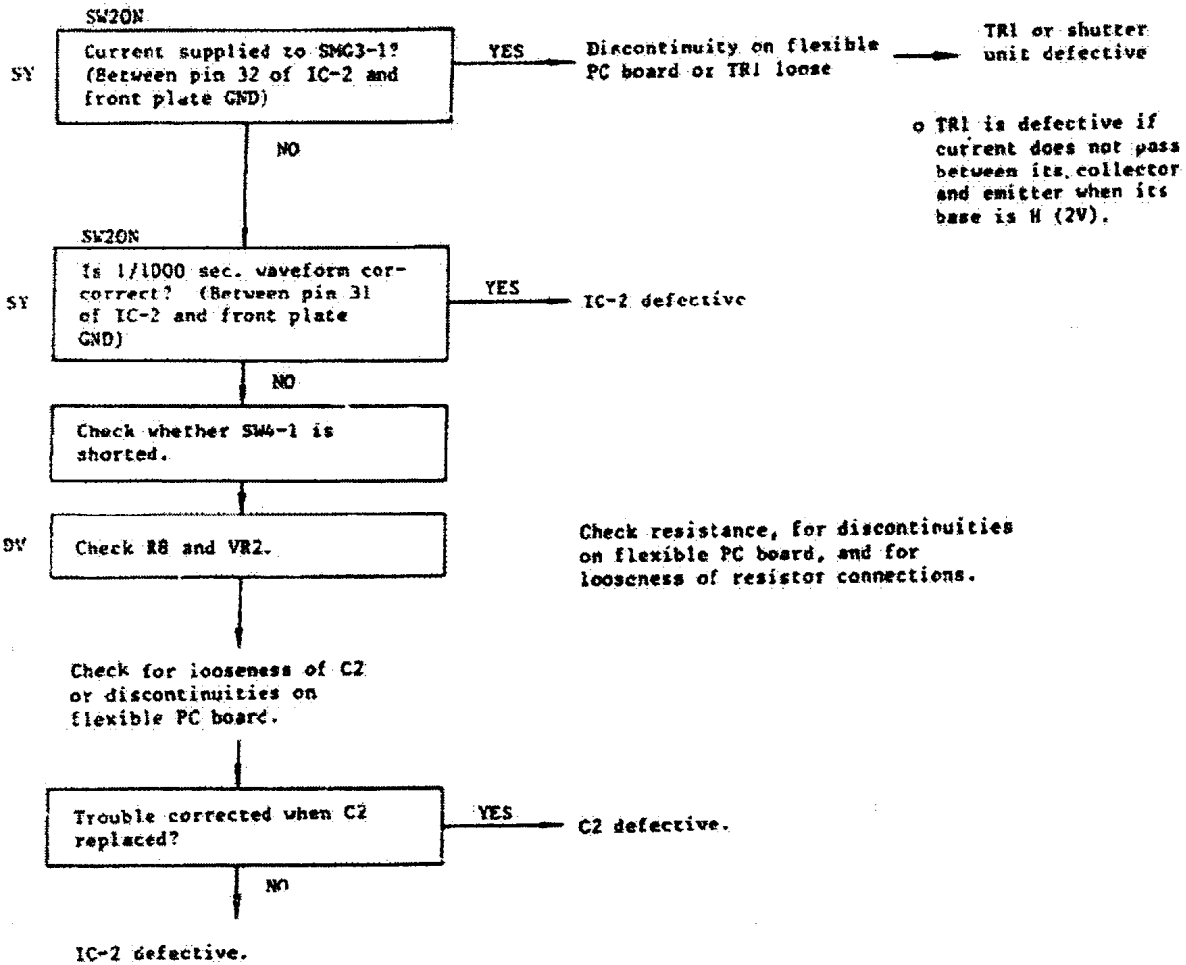

6. 2nd Curtain doesn't Travel

(SY - Use synchroscope; DV - Use digital voltmeter)

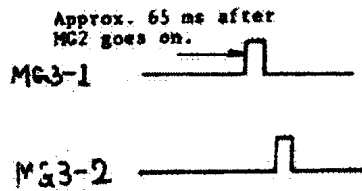
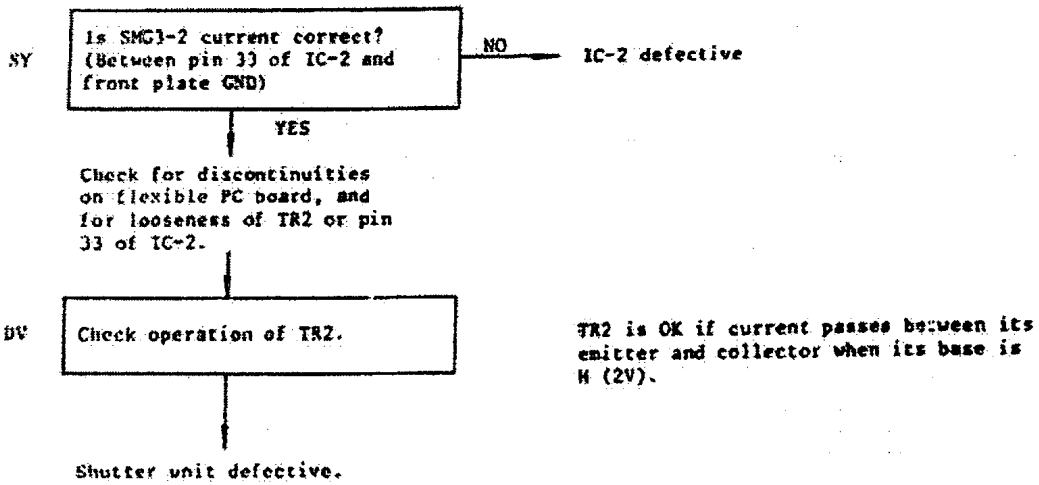

7. Level Adjustment not Possible (DV: Use digital voltmeter)

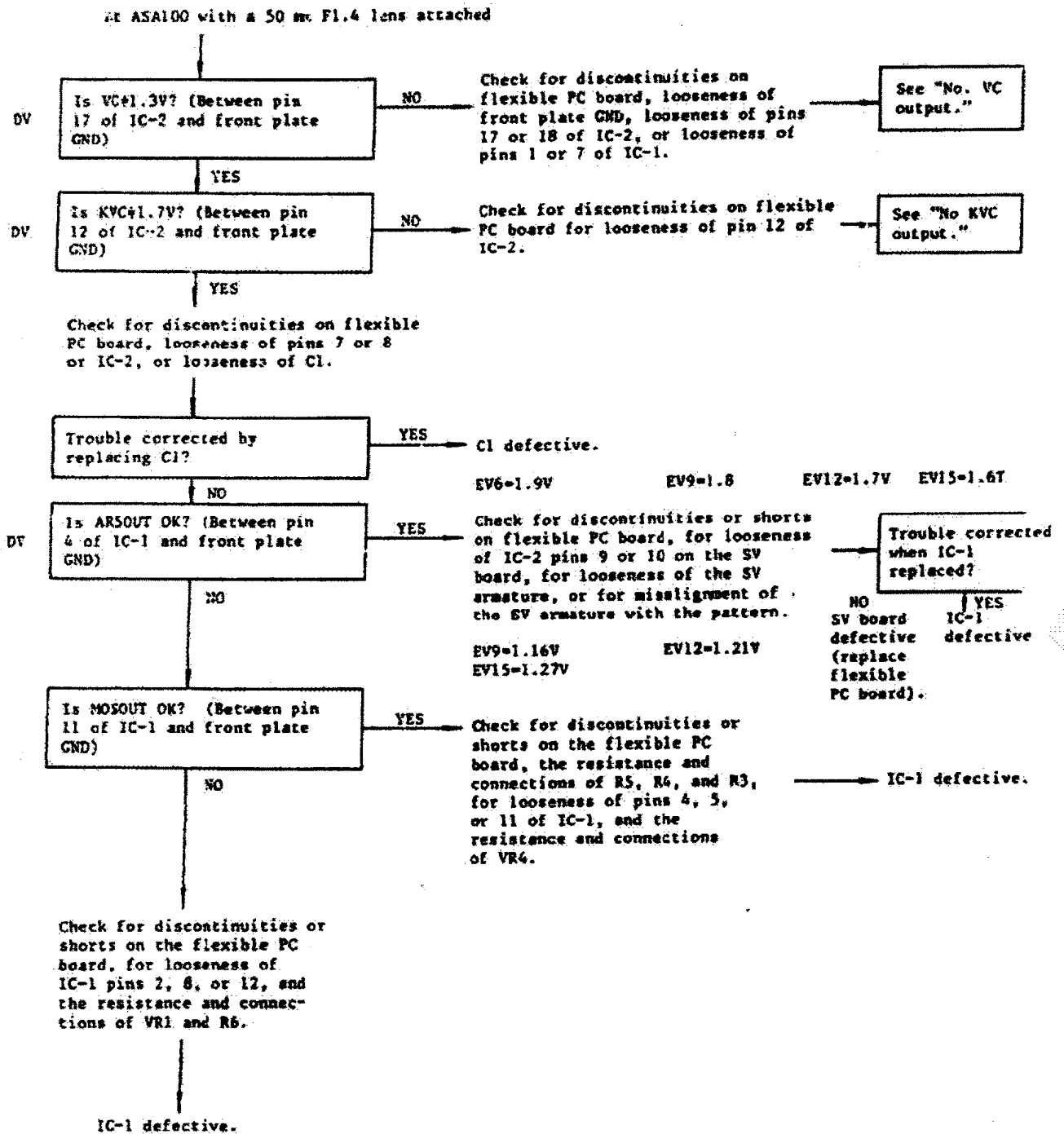

466

8. Aperture Set to Minimum during AE

(SY: Use Synchroscope.)

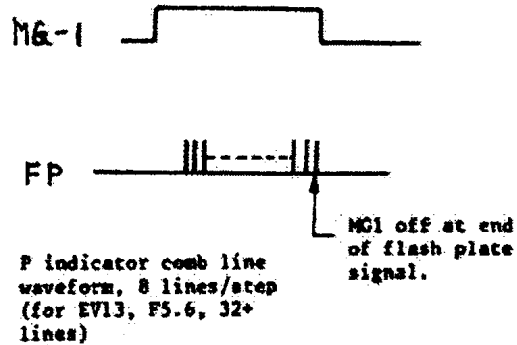
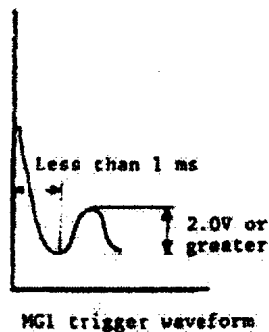
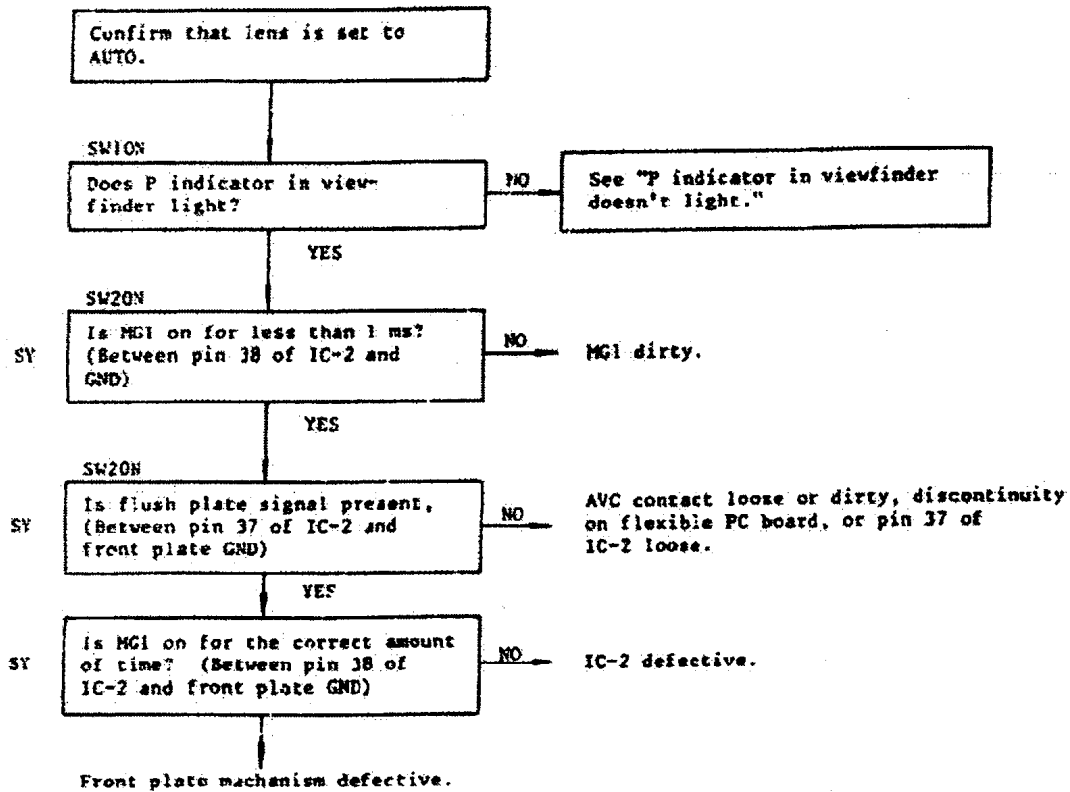

9. Aperture Fully Open during AE

(SY: Use synchroscope)

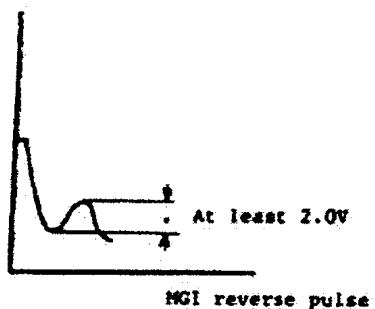
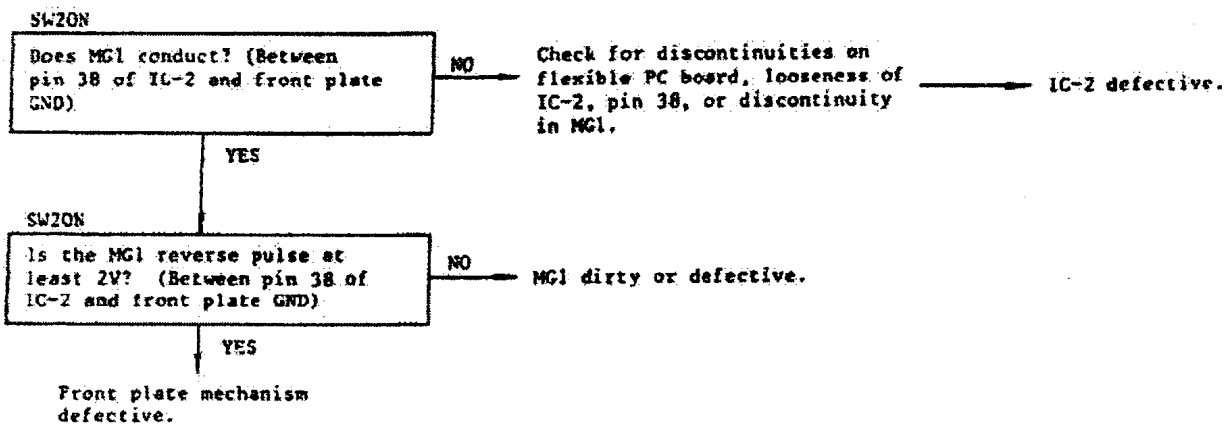

10. Self Timer doesn't Operate

(DV: Use digital voltmeter)

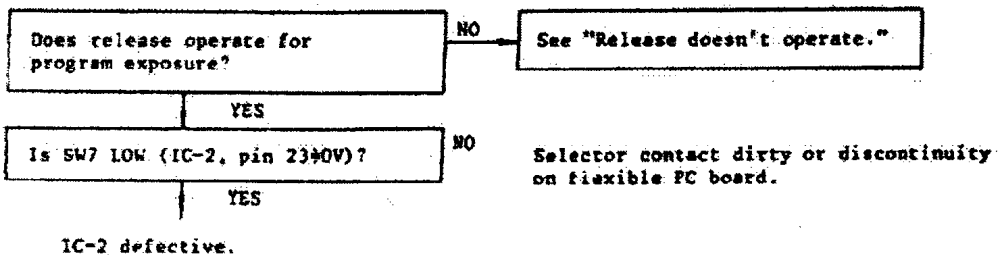

Battery check doesn't work

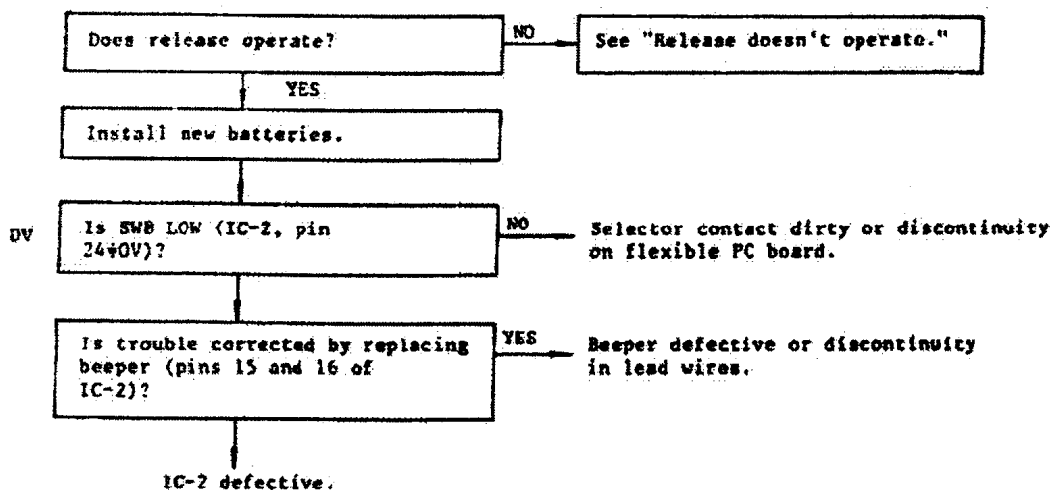

Film tension warning doesn't sound.

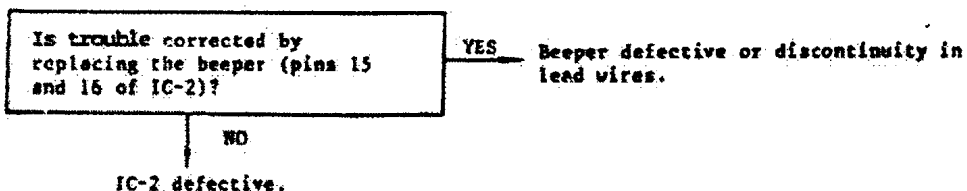

11. Remote Control Not Possible

(DV: Use digital voltmeter.)

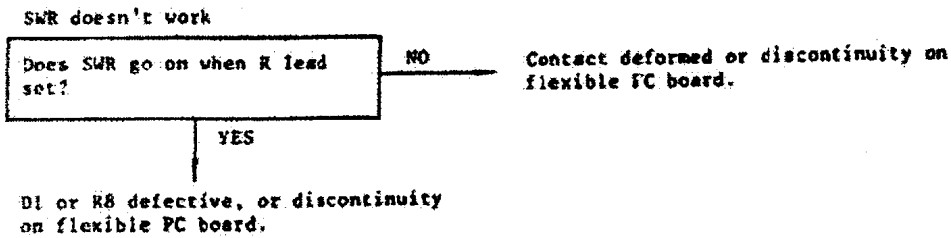
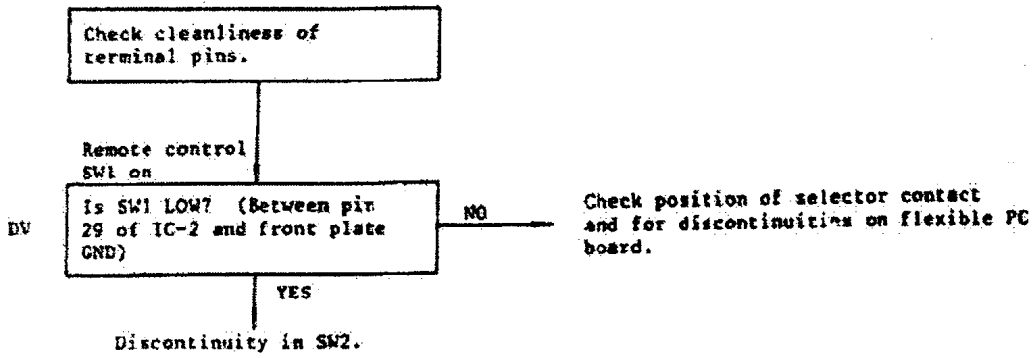

12. CNT Inoperative

(DV: Use digital voltmeter.)

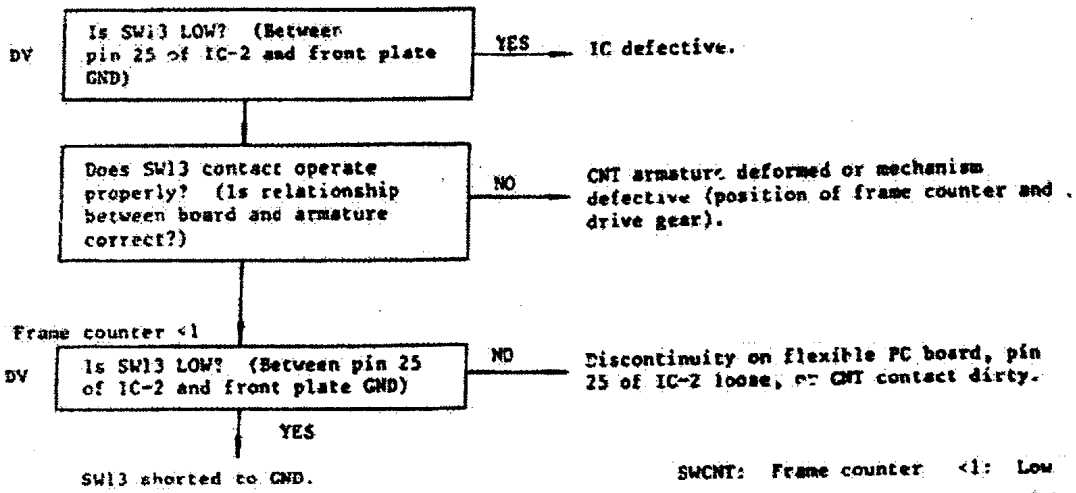

71

13. Inhibit Voltage Incorrect

(DV: Use digital voltmeter.)

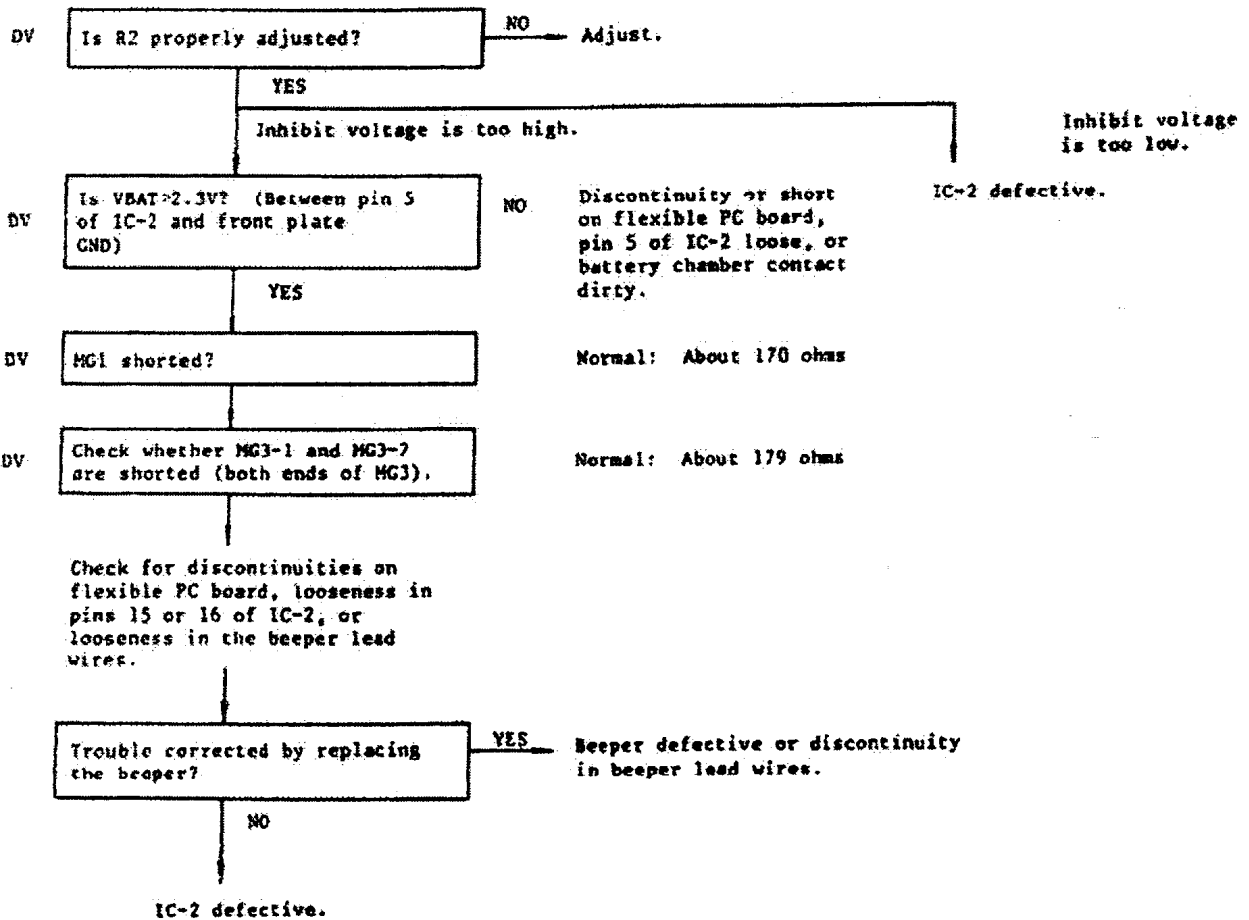

Leak Current (DV: Use digital voltmeter.)

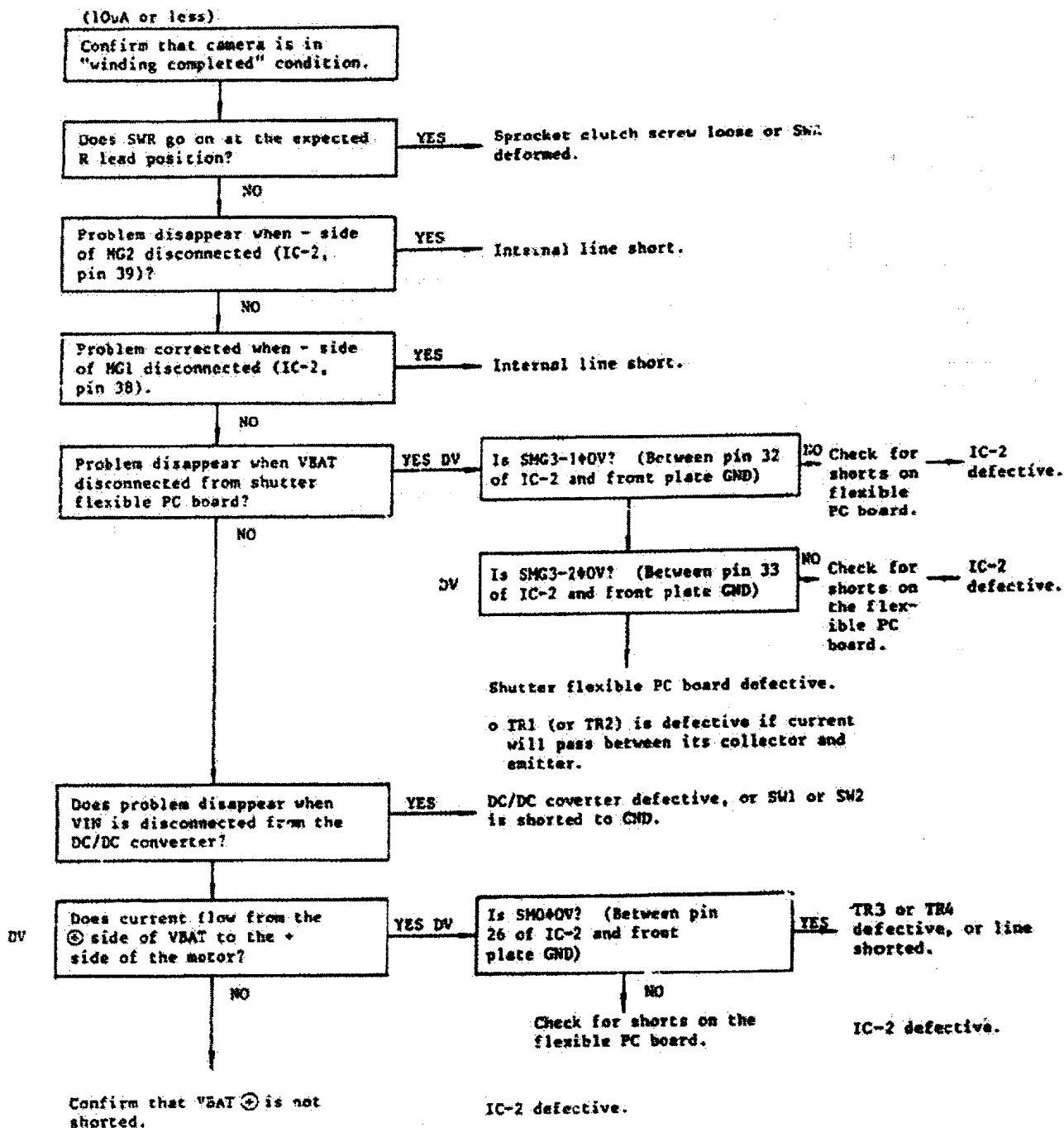

15. "P" in Viewfinder doesn't Light

(DV: Use digital voltmeter.)

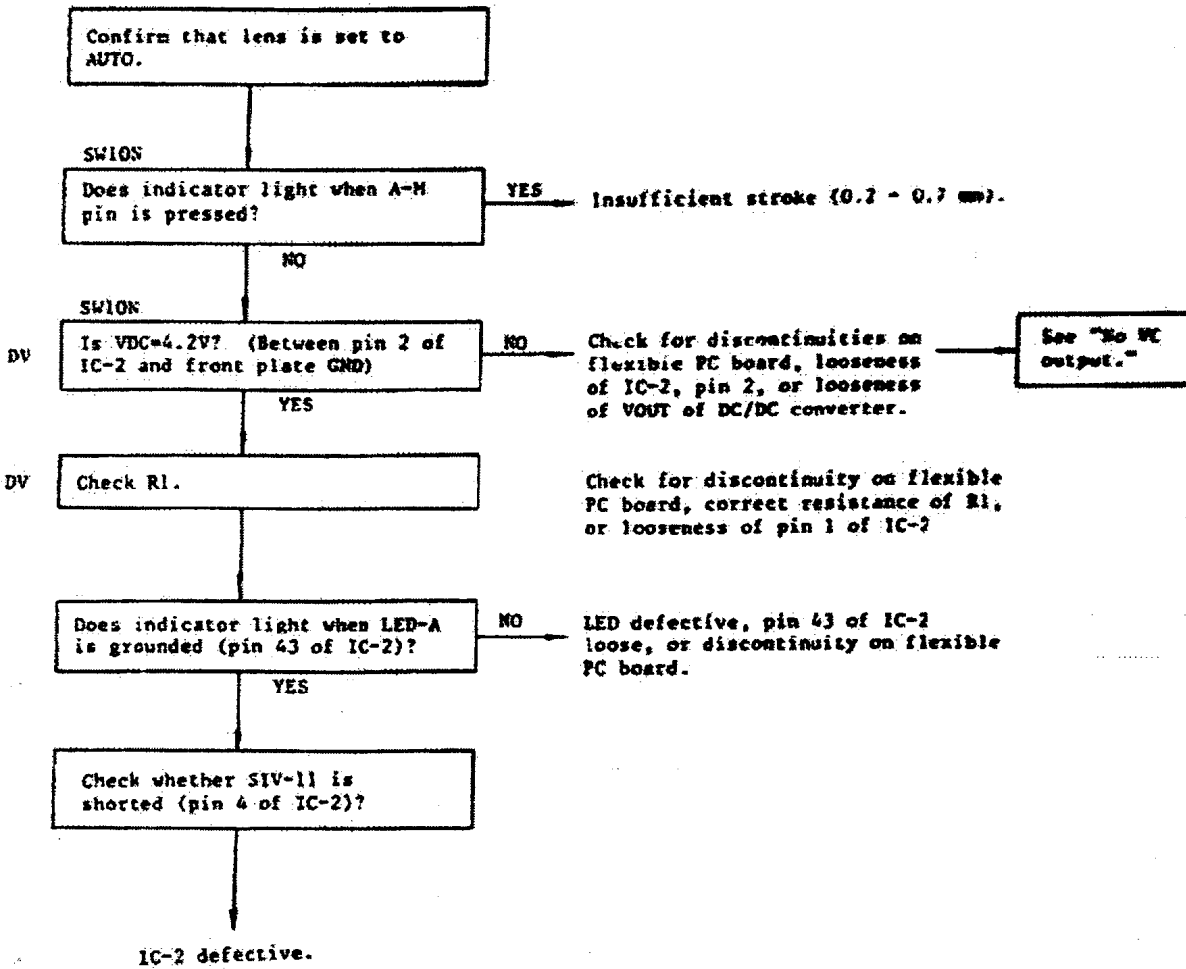

16. "f" in Viewfinder doesn't Light

(DV: Use digital voltmeter.)

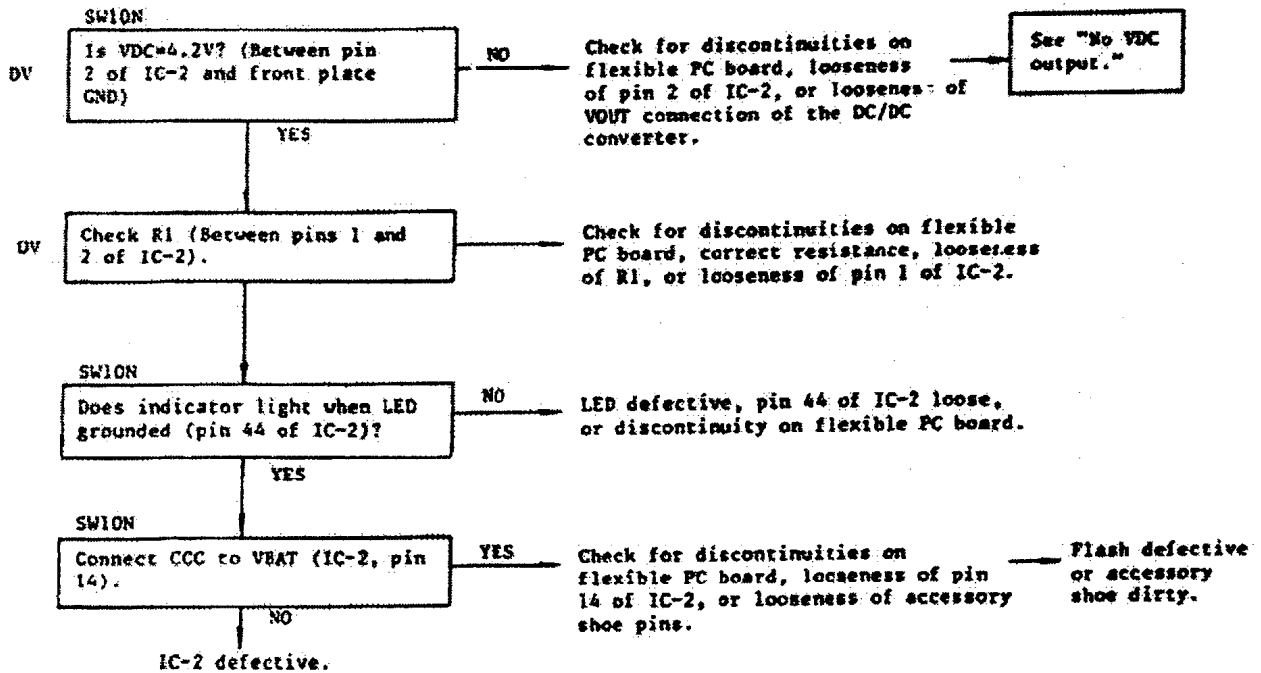

17. "M" in Viewfinder doesn't Light

(DV: Use digital voltmeter.)

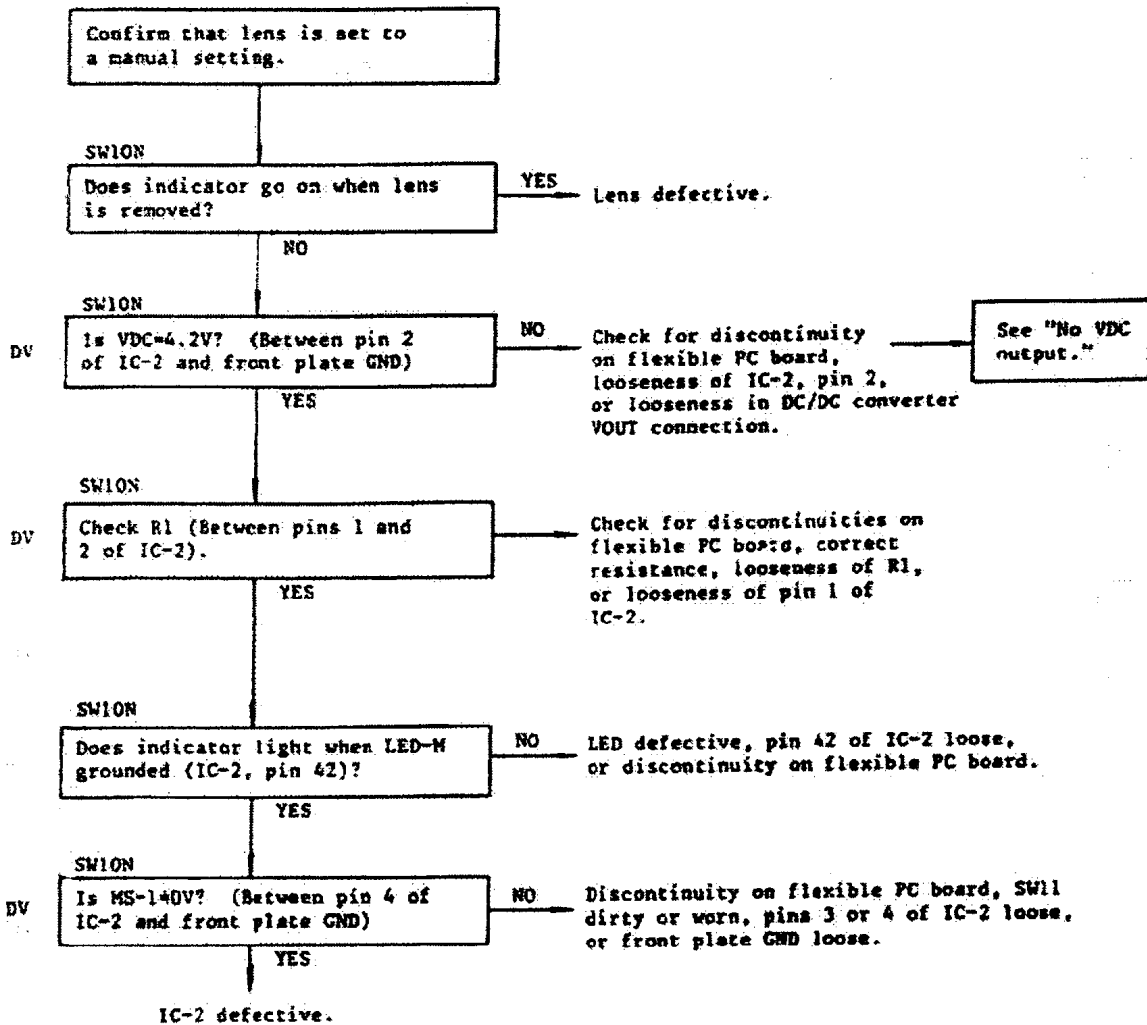

12

76

S E R V I C E T O O L S L I S T

C A N O N T 5 0

MEASUREMENT

TEST EQUIPMENT

1. Shutter
Shutter Tester (7J-18C, FL-200, etc)
or Simplified Shutter Tester (7E-24,
FL-1D, etc.)
2. Exposure Meter
 - 2.1 Canon Light Source-4 (2854K)
 - 2.2 D.C. Voltage Tester (1mV, 1uA specs.)
 - 2.3 Ohmmeter
 - 2.4 Standard Brightness Checker (CdS) or
Canon Luminance Meter (SBC)
 - 2.5 Multi Camera Tester EF-500AC
3. Viewfinder
Universal 600mm Range-viewfinder
Collimator or equivalent.
4. Electrical Adjustments
 - 4.1 Digital Multimeter (DMM)
 - 4.2 Oscilloscope
 - 4.3 Regulated Voltage Power Supply (LVPS)
 - 4.4 Ohmmeter
 - 4.5 AE Standard Tool Lens
5. Mirror angle (45°)
 - 5.1 Universal Type 90° Collimator or
 - 5.2 Simplified 90° Collimator
 - 5.3 Traveling Microscope
6. Flange to Focal Plane
Distance (FFD)
42.14mm Dial Gage Set
7. Mechanical
 - 7.1 Dial Tension Gage-600g
 - 7.2 Correx Tension Gage 0 - 50g
 - 7.3 Correx Tension Gage 0 - 300g
 - 7.4 Retaining Ring Pliers (AOG type)*
 - 7.5 Depth Micrometer*
 - 7.6 2.5mm Hex Key (Mirror Angle)

* : Local Purchase

CONTENTS

	Page	Address
1. Canon EMAS Shutter Specifications	1	G-4
2. Repair Precautions	4	G-7
3. Shutter Blade Replacement, SW5 and X Contact Cleaning	6	G-9
4. Shutter Service Checkpoints	8	G-11

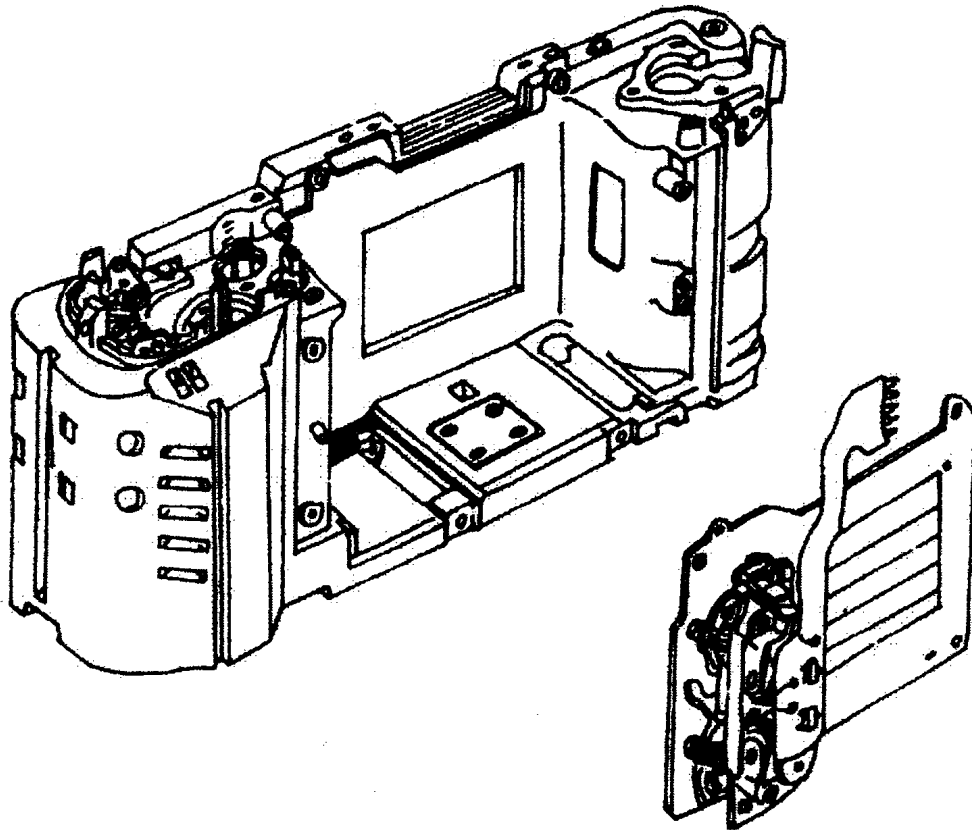

COPYRIGHT © Canon Inc.
Camera Service Administration Division
Camera Service Department
P.O. Box 5050
Shinjuku Dai-Ichi Seimei Bldg. Post Office
Tokyo 160, Japan

1. Canon EMAS Shutter Specifications

1.1 Type

Decending vertical-travel focal plane shutter

1.2 Shutter Blades

Parallel motion linkage

1.3 Driving Power

Separate torsion springs for 1st and 2nd curtain blades

1.4 Control

Dual Attraction Magents

1.5 Electronic Flash Synchronization Speed

1/60 second

1.6 Signal Outputs

X synchronization, 2nd curtain run complete

1.7 Curtain Travel Time

8 ms

1.8 Power Requirement

(Mechanical)

< 400 g

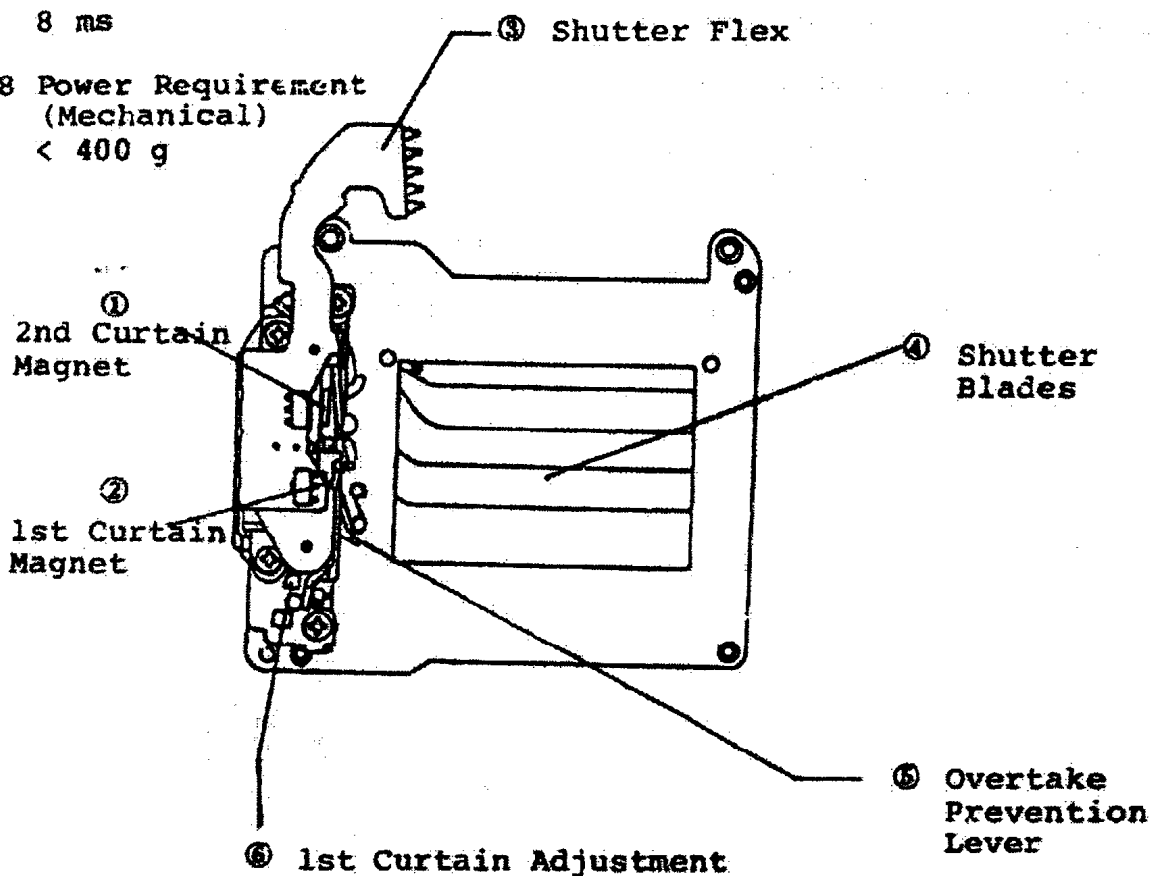

(1) and (2) Curtain Magnets

Structure: Coil and armature electromagnet

System : When current flows through the coil it attracts the armature which directly releases the curtain latch.

(3) Flex

1. Connects shutter to camera circuitry and carries X and 2nd curtain completion signal and well as magnet current.

2. Includes two transistors for the magnet circuits.

(4) Shutter Curtains (5 blade curtains)

Structure: Both curtains are composed of five blades. Linkage produces rhomboidal motion with slit moving from top to bottom of film aperture.

Material: Mylar base with nickel coating and black paint finish.

(5) Overtake Prevention

This mechanism prevents the shutter from running without opening so the 2nd curtain completion signal is not issued if the 1st curtain does not run.

(6) 1st Curtain Adjustment Mechanism

Structure: Worm and worm wheel adjust the torsion of the 1st curtain drive spring.

Note: The 2nd curtain drive spring torsion cannot be adjusted after the shutter is installed in the camera, and unevenness is adjusted with the 1st curtain.

Canon EMAS Shutter - Exploded View

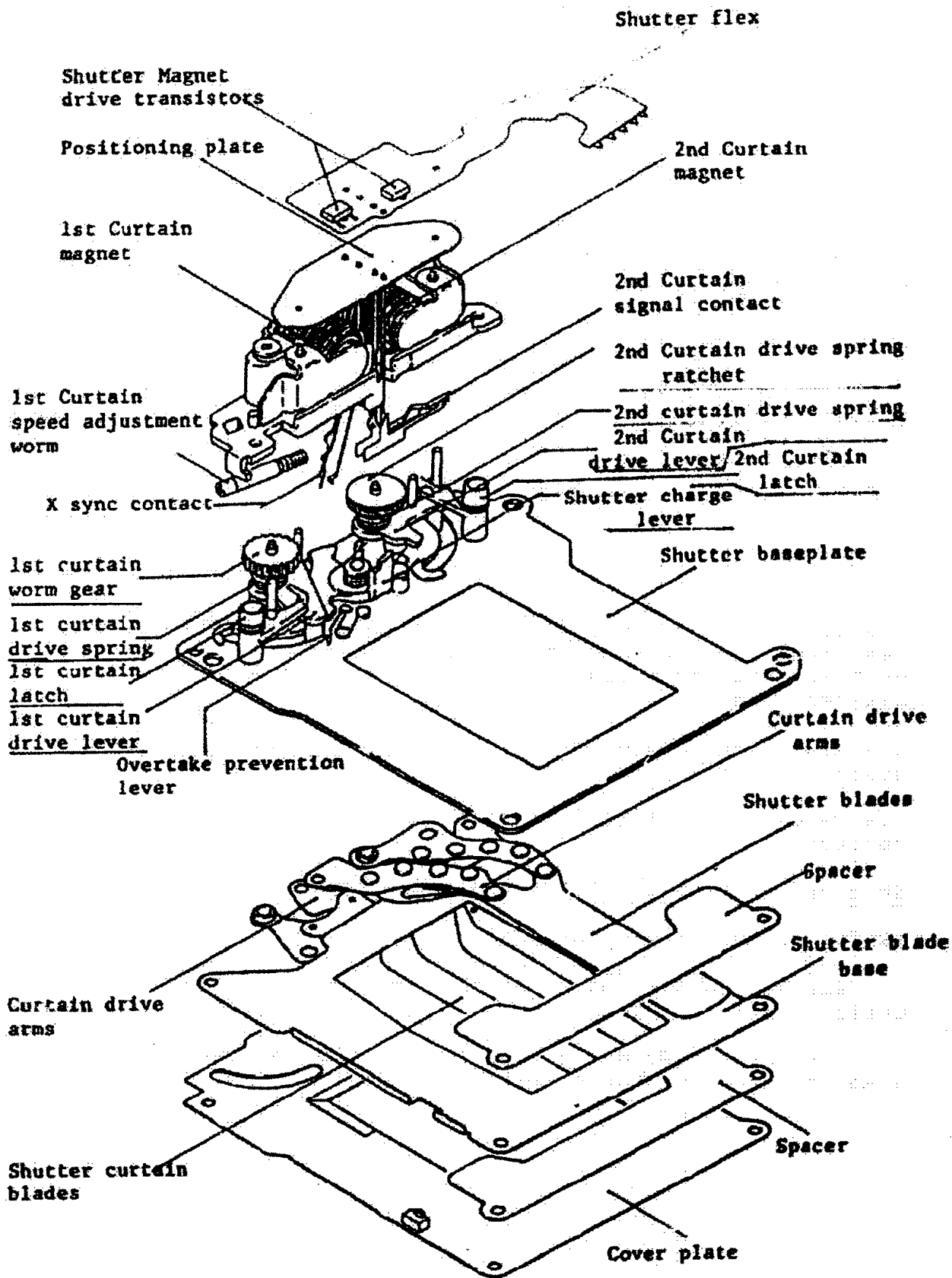

2. Repair Precautions

2.1 Do not touch the upper or lower edge of the shutter unit. When the shutter is charged the shutter blades protrude slightly and may be damaged if touched.

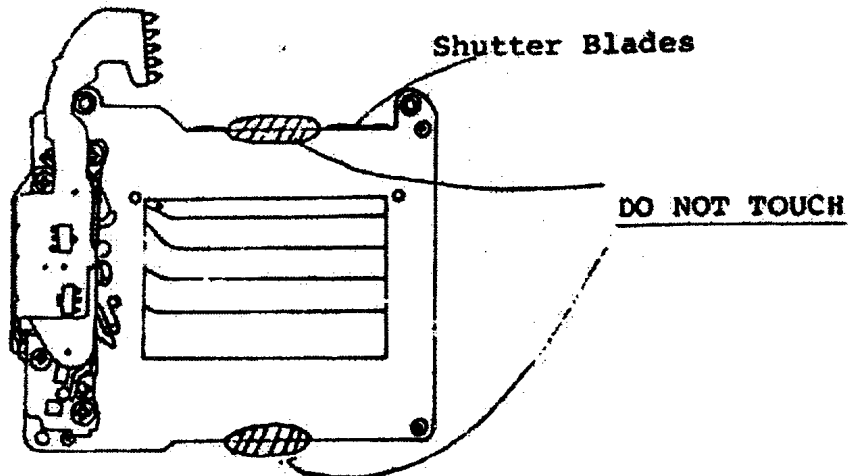

2.2 Do not touch the blades with naked fingers because the resultant fingerprints are difficult to remove. The blades must be completely flat so they should be handled with extreme care.

2.3 Always store and install the unit with in the released state. This is to protect the shutter curtain blades.

2.4 Be careful not to touch the X contact while charging the shutter.

Shutter Charging and 1st Curtain Release

(Refer to the drawing on page 3).

Shutter Charge: Move the shutter charge lever clockwise until it sets.

1st Curtain Release: Lightly push the 1st curtain magnet armature and the shutter will release.

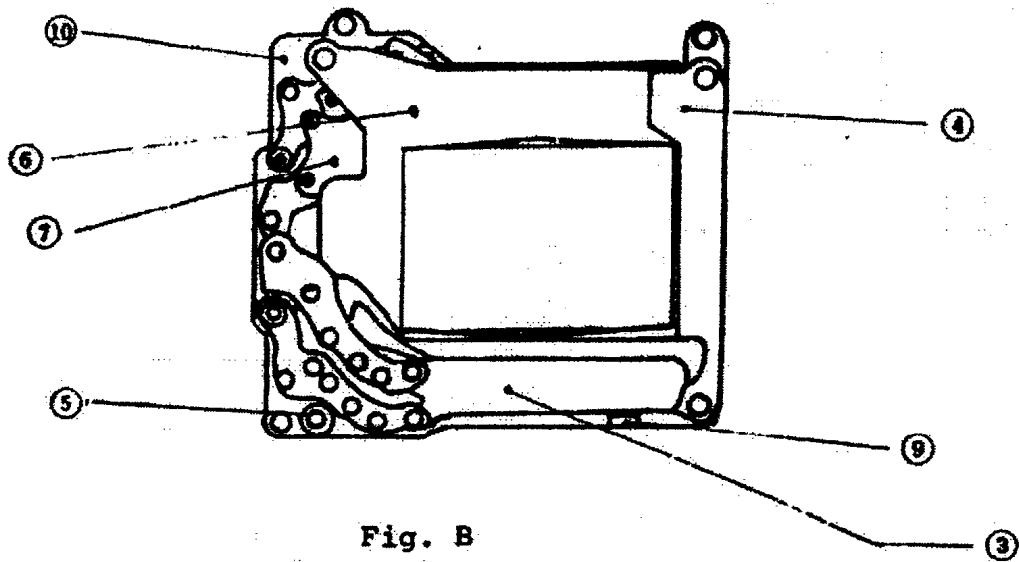
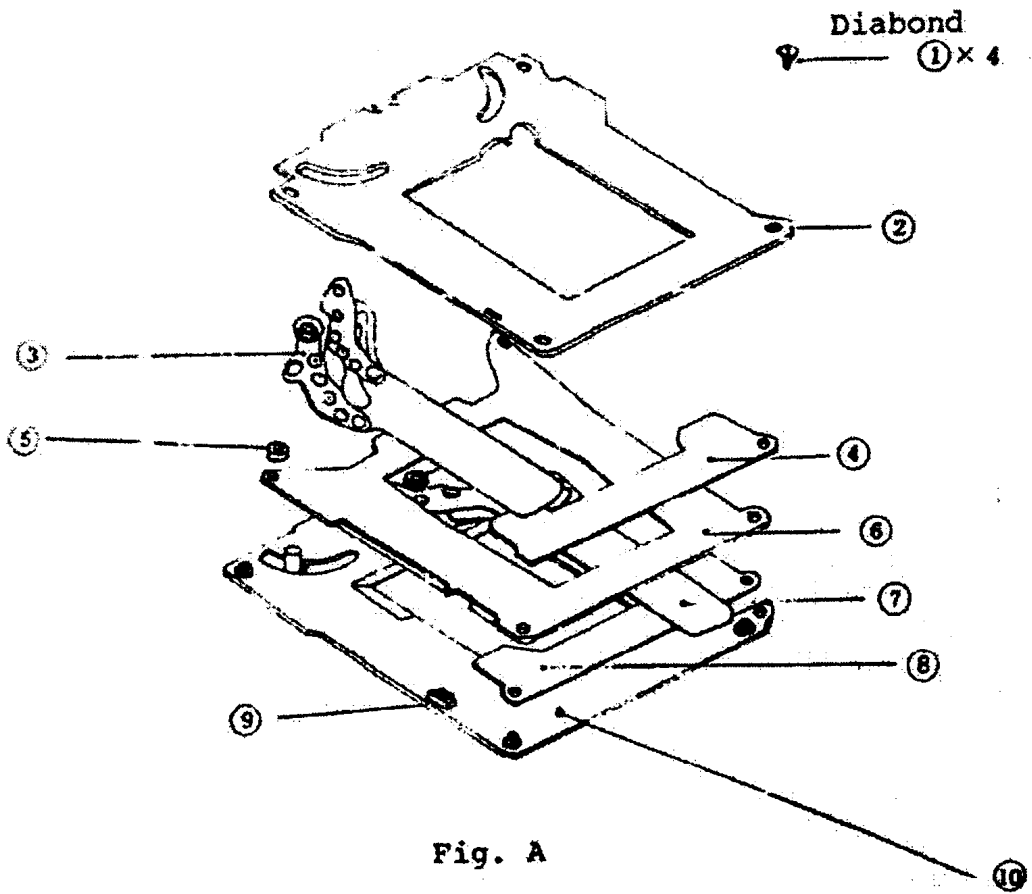

3. Shutter Blade Replacement, SW5 and X Contact Cleaning

3.1 Shutter Blade Replacement

Disassemble the shutter in the order indicated on the facing page. After disassembly, the blades can be changed.

Assembly

Set the shutter in the open condition with the 1st curtain drive lever.

In this condition, install the shutter curtain blades, matching the points shown at the right. The result should be as shown on the facing page (Fig. B).

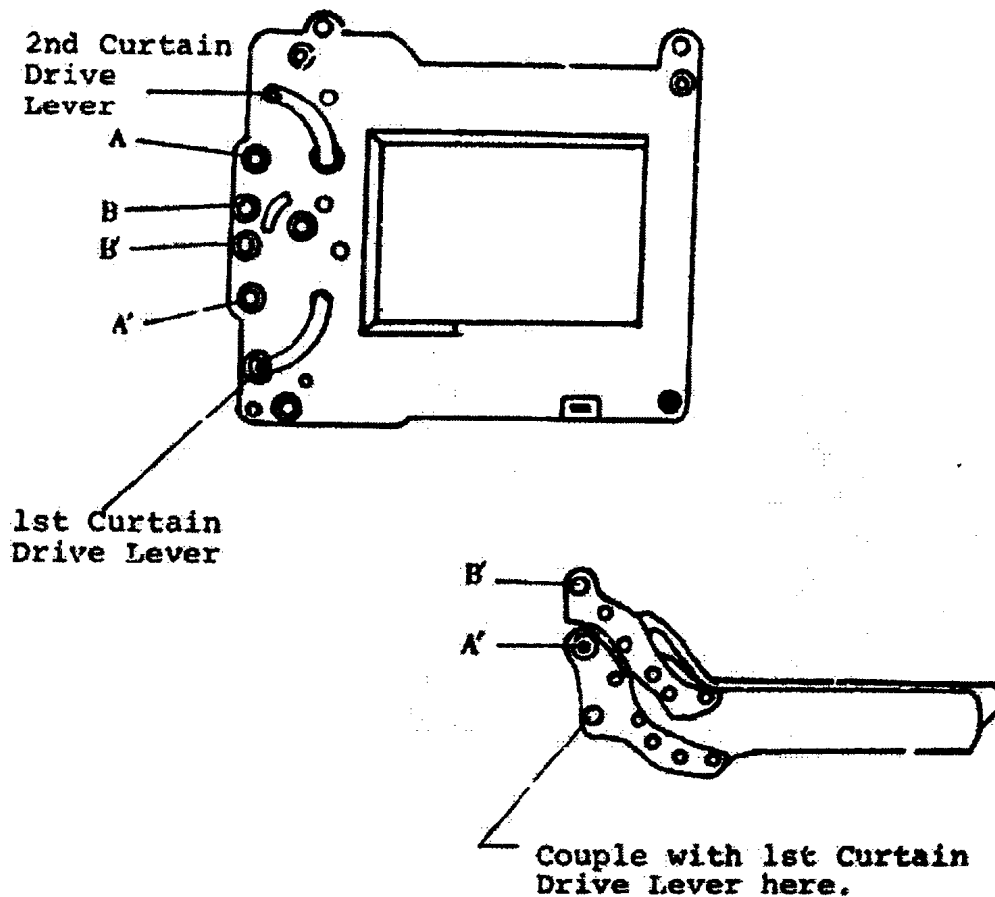

3.2 SW5 and X Contact Cleaning

Clean the switches after removing the shutter blades.

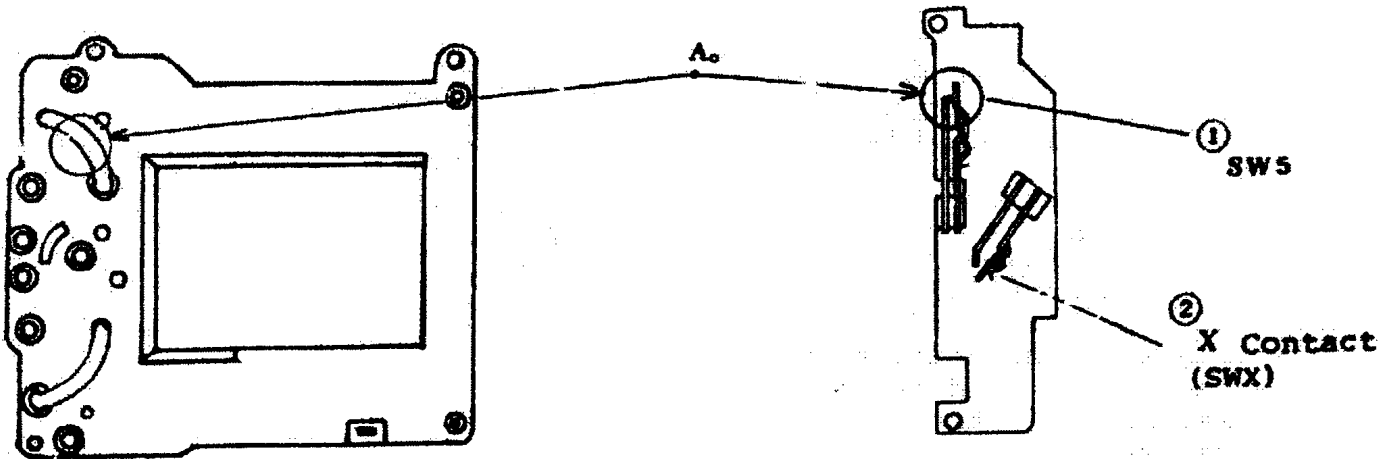

SW5: Clean SW5 through the curtain drive lever slot (A) with lens tissue wrapped on tweezers.

X Contact: The X contact can be cleaned without disassembling the shutter unit (Ref. pg. 3).

Be careful not to bend any of the contacts since this can effect shutter curtain bounce.

Switch Contact Clearances

SW5: 0.4 ± 0.1 mm

X Contact: 0.35 ± 0.1 mm

4. Shutter Service Checkpoints

A. Shutter Charged

4.1 In the shutter released (B) condition, the 2nd curtain rivit should be positioned as shown.

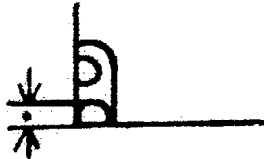

(At least 1/3 of the rivit should be covered)

4.2 With the shutter charged (A), if the 2nd curtain is released it should stop mid-way through its travel (C).

4.3 Insure that the release lever returns smoothly when the shutter is released.

4.4. Check the shutter blades for soil, fingerprints, scratches and loose rivits.

4.5 Flex Checkpoints

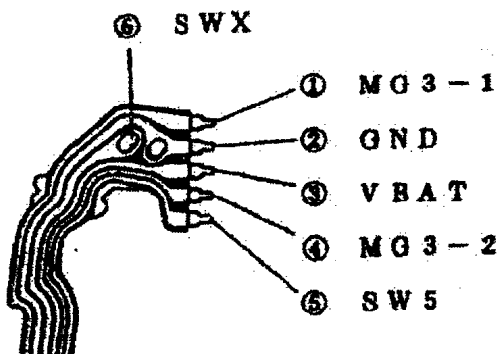

SW5 and SWX (X contact) can be checked as follows.

1st Curtain run complete:
Continuity between 6 and 2.

2nd Curtain run complete:
Continuity between 5 and 2.

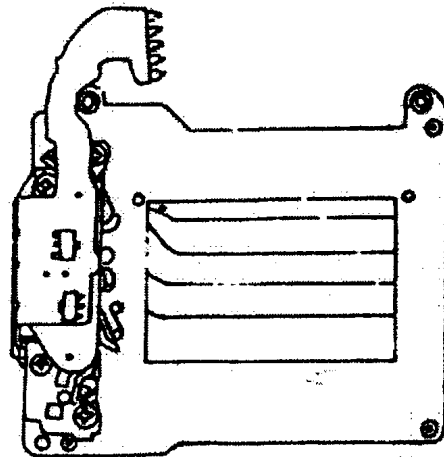

B. Shutter released

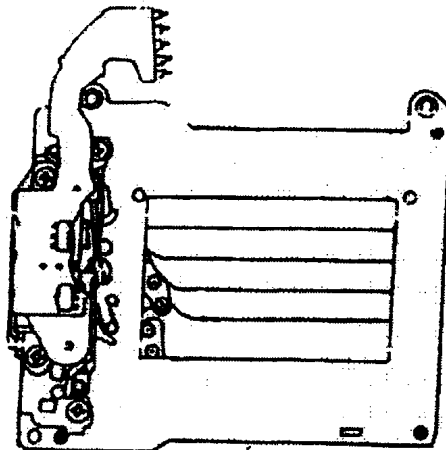

C. Overtake Prevention

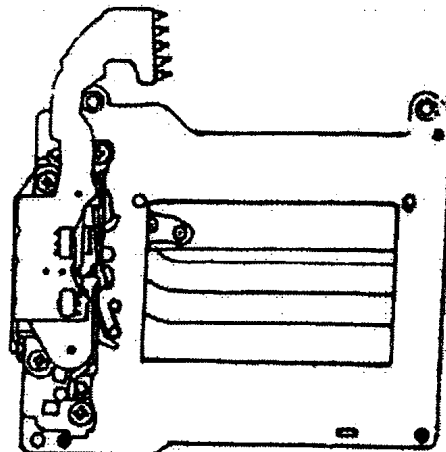

82

86

CANON T50 SERVICE PARTS POLICY

1. THE POLICY OF CAMERA SERVICE, TOKYO, IS TO STOCK ALL PARTS NECESSARY TO EFFECT EFFICIENT ECONOMICAL SERVICE. IT IS NEITHER NECESSARY NOR TECHNICALLY FEASIBLE TO STOCK SEPARATELY EVERY PART THAT GOES INTO EACH PRODUCT.

IN ESTABLISHING THE SPARE PARTS LIST, WE CONSIDER REPAIR DIFFICULTY, LABOR COST, SPECIAL TOOL REQUIREMENTS AND INDIVIDUAL PARTS VS. ASSEMBLED UNIT COST TO DETERMINE IN WHICH FORM PARTS WILL BE STOCKED.

2. A RECENT REVIEW HAS SHOWN THAT IT IS MORE ECONOMICAL AND ADVANTAGEOUS TO THE CUSTOMER, THE SERVICE FACILITY AND US TO STOCK INDIVIDUAL PARTS UNLESS THERE IS AN OVERRIDING REASON FOR STOCKING PRE-ASSEMBLED UNITS.

THE UNITS LISTED BELOW ARE STOCKED AS UNITS BECAUSE THEY REQUIRE TOOLS OR TECHNIQS NOT NORMALLY AVAILABLE AT FIELD SERVICE LEVEL.

CG1-0200-000	MOTOR UNIT	CY1-1113-000	SHUTTER FLEX
CG9-2581-000	ROLLER HOLDER UNIT		

IN ADDITION TO THE ABOVE, WHICH ARE STOCKED ONLY AS UNITS, SOME INDIVIDUAL PARTS ARE STOCKED FOR THE FOLLOWING UNITS IN ADDITION TO THE UNIT.

CG1-0173-000	SHUTTER UNIT	CG1-0209-000	AE UNIT
CG1-0199-000	TOP COVER UNIT	CY1-1112-000	SPOOL GEAR UNIT
CG1-0201-000	ELECTRIC PARTS UNIT	CY1-1115-000	BACK COVER UNIT
CG1-0207-000	MIRROR MECHANISM	CY1-1116-000	MIRROR UNIT
CG1-0208-000	AUTO DIAPHRAGM UNIT	CY1-1120-000	MAGNET 2 UNIT

3. INDIVIDUAL ELECTRICAL COMPONENTS WHICH MAY REQUIRE REPLACEMENT ARE STOCKED.

4. THE SPARE PARTS LIST IS ADJUSTED PERIODICALLY TO INSURE THE NECESSARY PARTS ARE ALWAYS AVAILABLE, AND UNNECESSARY PARTS ARE REMOVED FROM THE STOCK LIST.

5. ASSEMBLIES SHOWN WITH THE N.S. MARK ARE SHOWN FOR CLARITY ONLY. THEY ARE NOT STOCKED IN THE FORM SHOWN.

キヤノン T50 サービス部品について

サービス部品は修理上の精度、工数、コスト、部品の使用頻度等、諸々の事由を勘案し、設定している。

特にユニット部品の構成部品中で、使用頻度の少ないものはサービス部品とはしない。
キヤノンT50においては次のような部品設定とする。

下記部品はユニットのみをサービス部品とする。

CG1-0200-000 モーターユニット CY1-1113-000 シャッターフレキユニット
CG9-2581-000 ローラーホルダーユニット

下記部品はユニット及び使用頻度の高いと考えられる部品をサービス部品とする。

CG1-0173-000 シャッターユニット CG1-0209-000 AE抵抗ユニット
CG1-0199-000 上蓋ユニット CY1-1112-000 スプールギヤユニット
CG1-0201-000 電気部品ユニット CY1-1115-000 背蓋ユニット
CG1-0207-000 ミラーQRユニット CY1-1116-000 ミラーユニット
CG1-0208-000 自動絞りユニット CY1-1120-000 Mg-2 ユニット

電気素子は一部のもの以外は、サービス部品としない。

※ 当初、サービス部品設定されない部品でも状況に応じ、サービス部品として追加することもある。

※ ユニットの一部でサービス部品としないものは N.S マークをつけてある。

以上

CONTENTS

	PAGE	ADDRESS
EXTERNAL PARTS	1	A-7,8
TOP COVER PARTS	2	A-9,10
BACK COVER & FILMCOUNTER	3	A-11,12
FINDER PARTS & ELECTRIC PARTS UNIT	4	A-13,14
REWIND SW & NECK STRAP LUG PARTS	5	B-1,2
MIRROR BOX UNIT PARTS	6	B-3,4
MIRROR MECHANISM, AUTO DIAPHRAGM & AE UNIT	7	B-5,6
PRINTED CIRCUIT BOARD & REWINDING PARTS	8	B-7,8
SWITCH & GEAR MECHANISM	9	B-9,10
SPROCKET & SHUTTER UNIT	10	B-11,12
MOTOR & GEAR MECHANISM	11	B-13,14
SHUTTER PARTS	12	C-1,2
WIRING DIAGRAM 1ST TYPE	13	C-3,4
WIRING DIAGRAM 2ND TYPE	14	C-5,6
ELECTRIC PARTS LIST	15	C-7
ELECTRIC PARTS LIST	16	C-8
INDEX OF PARTS NUMBERS	17-	C-9-

CANON T50

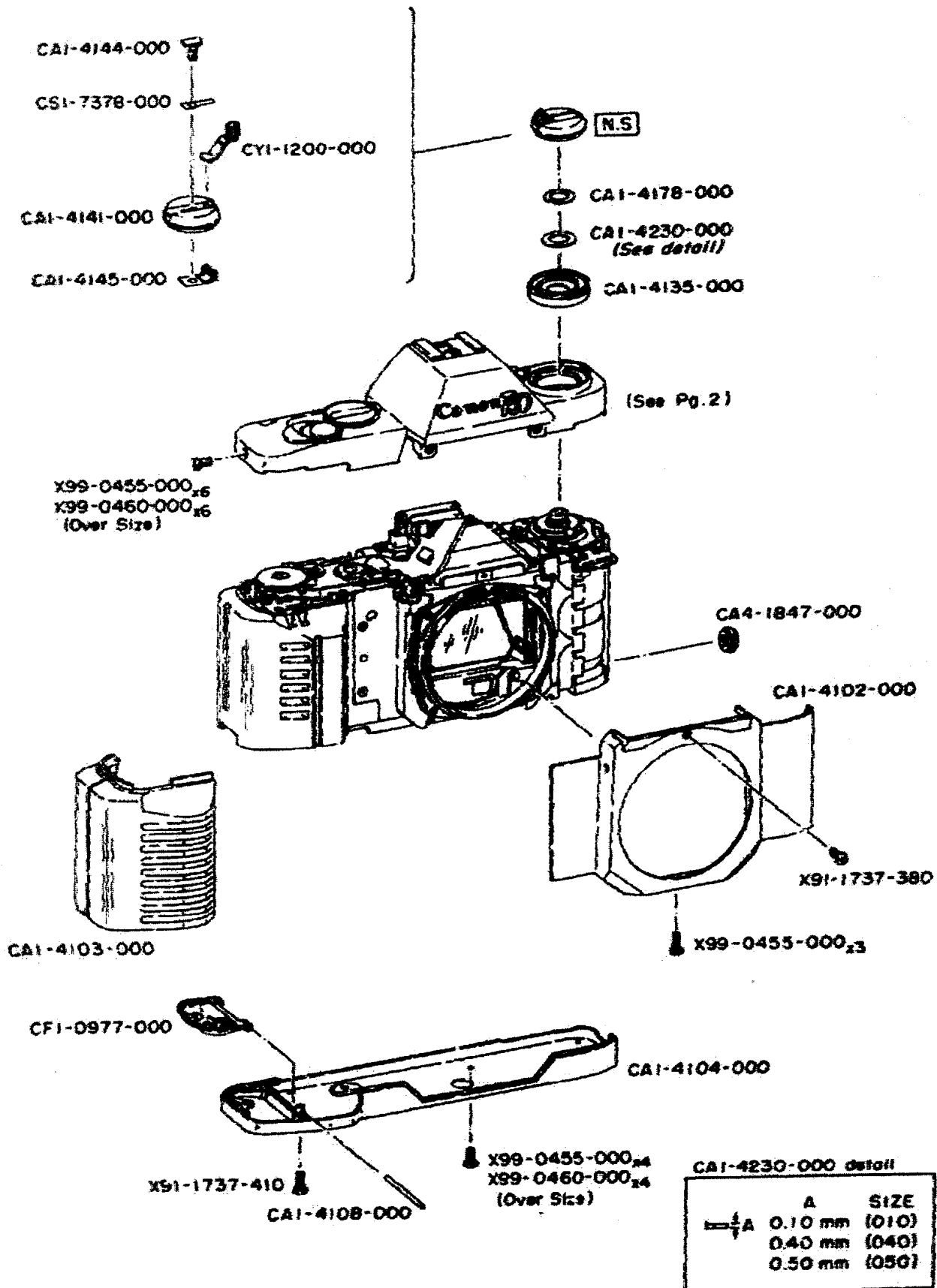

PARTS LIST

EXTERNAL PARTS

MARK	PART NO.	CLASS	QTY	DESCRIPTION
	CA1-4102-000	B	1	COVER, FRONT
	CA1-4103-000	C	1	COVER, GRIP
	CA1-4104-000	B	1	COVER, BASE
	CA1-4108-000	D	1	SHAFT, HINGE
	CA1-4135-000	D	1	DIAL, ASA
	CA1-4141-000	B	1	KNOB, REWIND
	CA1-4144-000	C	1	SCREW, REWIND CRANK
	CA1-4145-000	D	1	HOLDER, CRANK KNOB
	CA1-4178-000	E	1	RING, M.D
	CA1-4230-000	E	1	WASHER, ASA
	(ENTER SIZE WHEN ORDERING, SEE DETAIL)			
	CA4-1847-000	D	1	CAP, TERMINAL
	CF1-0977-000	C	1	COVER, BATTERY
	CS1-7378-000	D	1	SPRING, DETENT
	CY1-1200-000	D	1	CRANK, REWIND
	X91-1737-380		1	SCREW, CROSS-RECESS, PH
	X91-1737-410		1	SCREW, CROSS-RECESS, PH
	X99-0455-000		13	SCREW, CROSS-RECESS, PH
	X99-0460-000		10	SCREW, CROSS-RECESS, PH

CANON T50

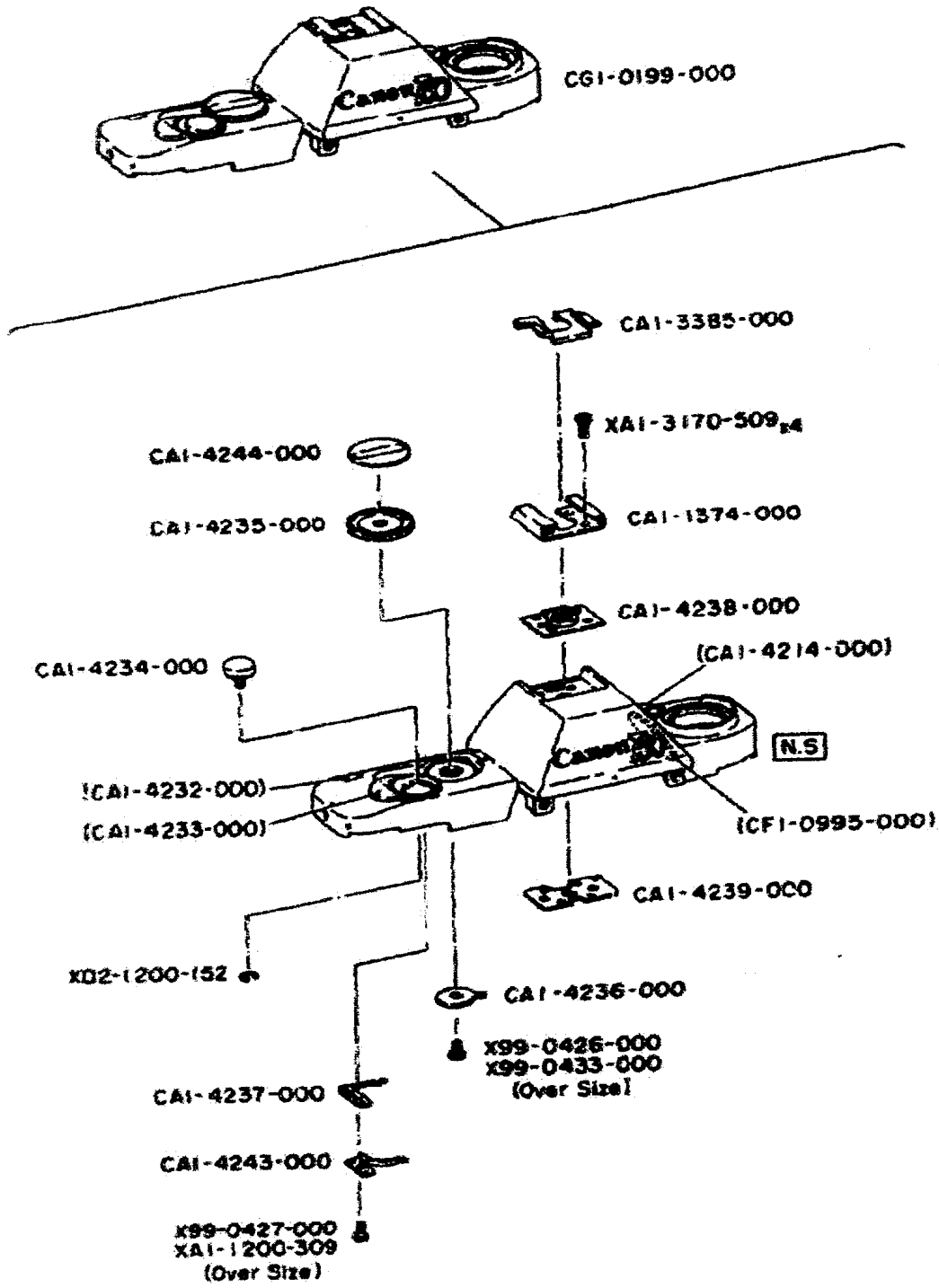

PARTS LIST

TOP COVER PARTS

MARK	PART NO.	CLASS	QTY	DESCRIPTION
	CA1-1374-000	B	1	SHOE, ACCESSORY
	CA1-3385-000	C	1	SPRING, PLATE (BL)
	CA1-4214-000	E	1	BUTTON, ASA RELEASE
	CA1-4232-000	D	1	WINDOW, FILM COUNTER
	CA1-4233-000	E	1	SEAT, SHUTTER BUTTON
	CA1-4234-000	E	1	BUTTON, RELEASE
	CA1-4235-000	D	1	SELECTOR, MODE
	CA1-4236-000	D	1	CLICK, SELECTOR
	CA1-4237-000	D	1	SPRING, SELECTOR
	CA1-4238-000	B	1	BASE, ACCESSORY SHOE
	CA1-4239-000	D	1	PLATE, MOUNTING
	CA1-4243-000	D	1	SPRING, B.C
	CA1-4244-000	D	1	DIAL, SELECTOR
	CF1-0995-000	E	1	BEEPER
	CG1-0199-000	B	1	TOP COVER UNIT
	XA1-1200-309		1	SCREW, CROSS-RECESS, PH
	XA1-3170-509		4	SCREW, CROSS-RECESS, FCH
	XD2-1200-152		1	E RING
	X99-0426-000		1	SCREW, CROSS-RECESS, PH
	X99-0427-000		1	SCREW, CROSS-RECESS, PH
	X99-0433-000		1	SCREW, CROSS-RECESS, PH

CANON T50

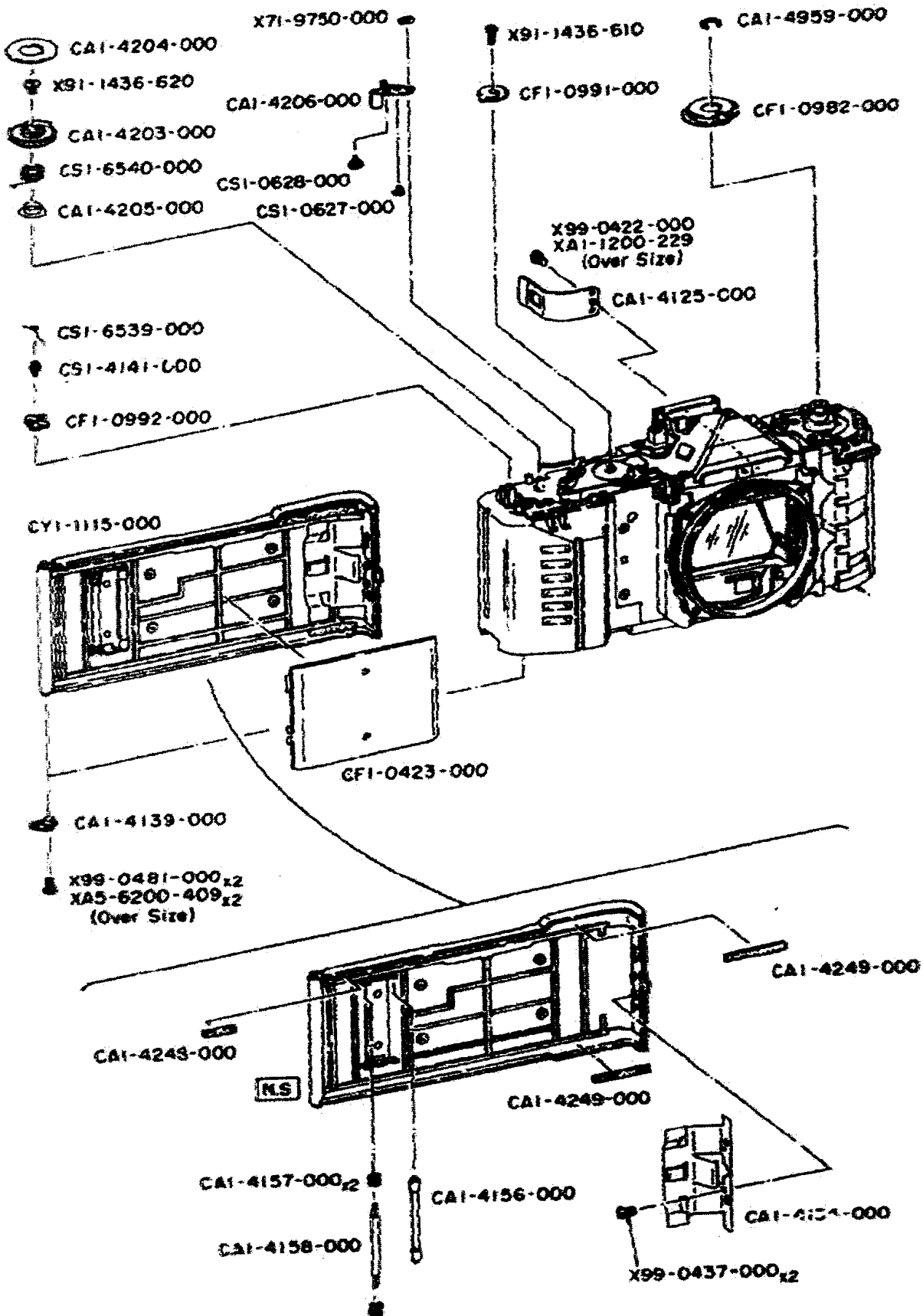

PARTS LIST

BACK COVER & FILMCOUNTER

MARK	PART NO.	CLASS	QTY	DESCRIPTION
	CA1-4125-000	D	1	GUIDE, CASSETTE
	CA1-4139-000	E	1	HINGE
	CA1-4154-000	D	1	HOLDER, CASSETTE
	CA1-4156-000	D	1	FILM GUIDE
	CA1-4157-000	D	2	ROLLER
	CA1-4158-000	D	1	ROLLER
	CA1-4203-000	D	1	GEAR, FRAME COUNTER
	CA1-4204-000	D	1	DIAL, FILM COUNTER
	CA1-4205-000	E	1	BUSHING
	CA1-4206-000	E	1	LEVER, RETURNING
	CA1-4248-000	E	1	SHIELD, LIGHT
	CA1-4249-000	E	2	SHIELD, LIGHT
	CA1-4959-000	B	1	C RING
	CF1-0423-000	D	1	PLATE, PRESSURE
	CF1-0982-000	D	1	CONTACT, ASA
	CF1-0991-000	D	1	BRUSH, SELECTOR
	CF1-0992-000	D	1	BRUSH, C.N.T
	CS1-0627-000	E	1	GEAR
	CS1-0628-000	E	1	GEAR
	CS1-4141-000	D	1	SCREW
	CS1-6539-000	E	1	SPRING
	CS1-6540-000	E	1	SPRING
	CY1-1115-000	C	1	COVER, BACK
	XA1-1200-229		1	SCREW, CROSS-RECESS, PH
	XA5-6200-409		2	SCREW, CROSS-RECESS, PH
	X71-9750-000		1	RETAINER
	X91-1436-610		1	SCREW, CROSS-RECESS, PH
	X91-1436-620		1	SCREW, CROSS-RECESS, PH
	X99-0422-000		1	SCREW, CROSS-RECESS, PH
	X99-0437-000		2	SCREW, CROSS-RECESS, PH
	X99-0481-000		2	SCREW, CROSS-RECESS, PH

CANON T50

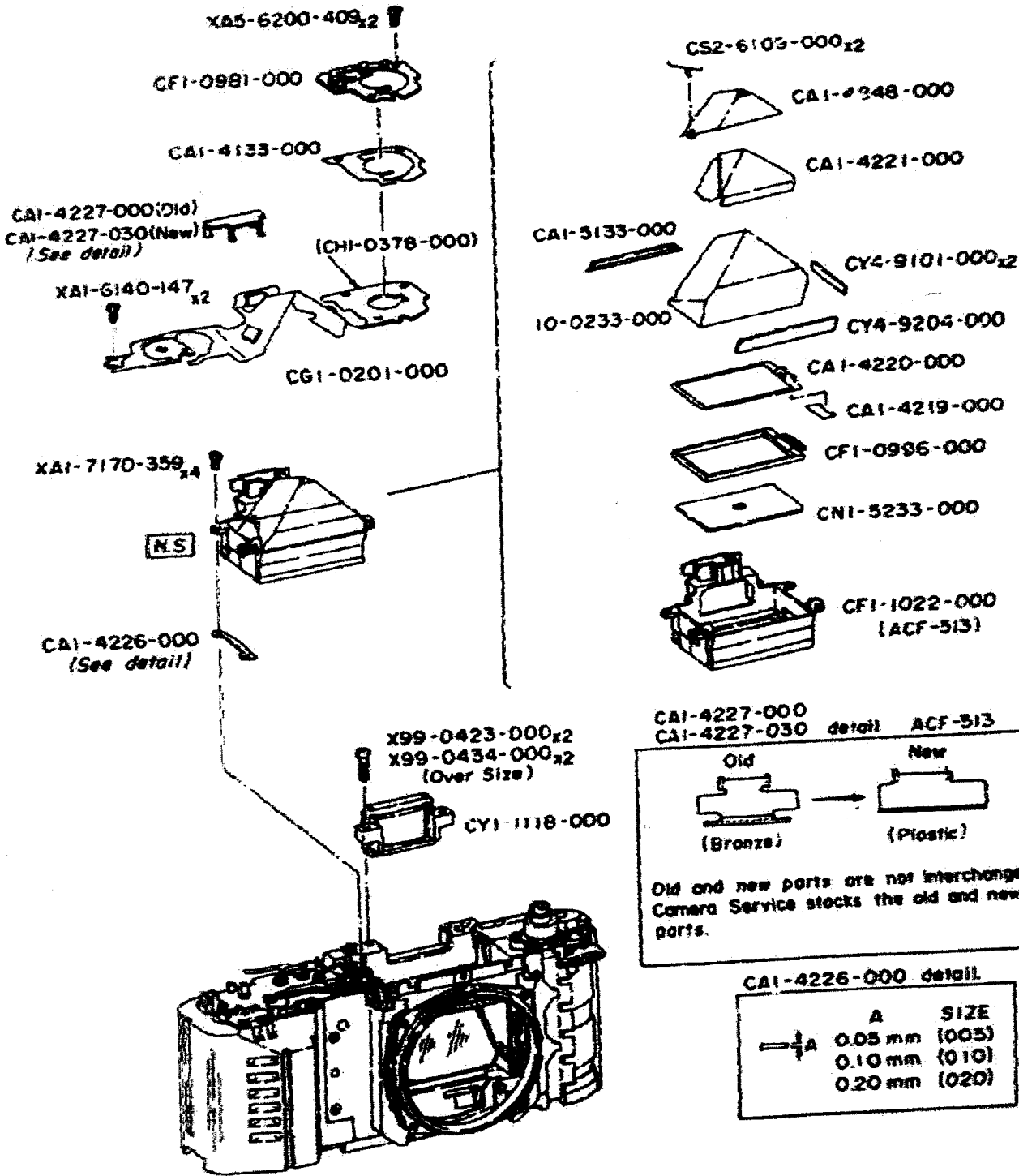

PARTS LIST

FINDER PARTS & ELECTRIC PARTS UNIT

MARK	PART NO.	CLASS	QTY	DESCRIPTION
	10-0233-000	C	1	PENTAPRISM
	CA1-4133-000	E	1	INSULATOR, ASA
	CA1-4219-000	E	1	MASK, INDICATOR
	CA1-4220-000	E	1	MASK, FINDER
	CA1-4221-000	E	1	COVER, PENTAPRISM
	CA1-4226-000	E	2	WASHER, ADJUSTING
	(ENTER SIZE WHEN ORDERING, SEE DETAIL)			
	CA1-4227-000	E	1	PLATE, STOPPER
	CA1-4227-030	E	1	PLATE, STOPPER
	CA1-4848-000	E	1	HOLDER, PENTAPRISM
	CA1-5133-000	D	1	SPACER
	CF1-0981-000	E	1	BASEPLATE, ASA
	CF1-0996-000	D	1	LED UNIT
	CF1-1022-C30	E	1	PENTAPRISM BOX
	GI-0201-000	B	1	ELECTRIC PART UNIT
	CH1-0378-000	E	1	BOARD, SV
	CN1-5233-000	C	1	SCREEN, FOCUSING
	CS2-6109-000	D	2	SPRING
	CY1-1118-000	B	1	EYEPIECE
	CY4-9101-000		2	TAPE
	CY4-920A-000		1	TAPE
	XA1-6140-147		2	SCREW, CROSS-RECESS, PH
	XA1-7170-359		4	SCREW, CROSS-RECESS, PH
	XA5-6200-409		2	SCREW, CROSS-RECESS, PH
	X99-0423-000		2	SCREW, CROSS-RECESS, PH
	X99-0434-000		2	SCREW, CROSS-RECESS, PH

CANON T50

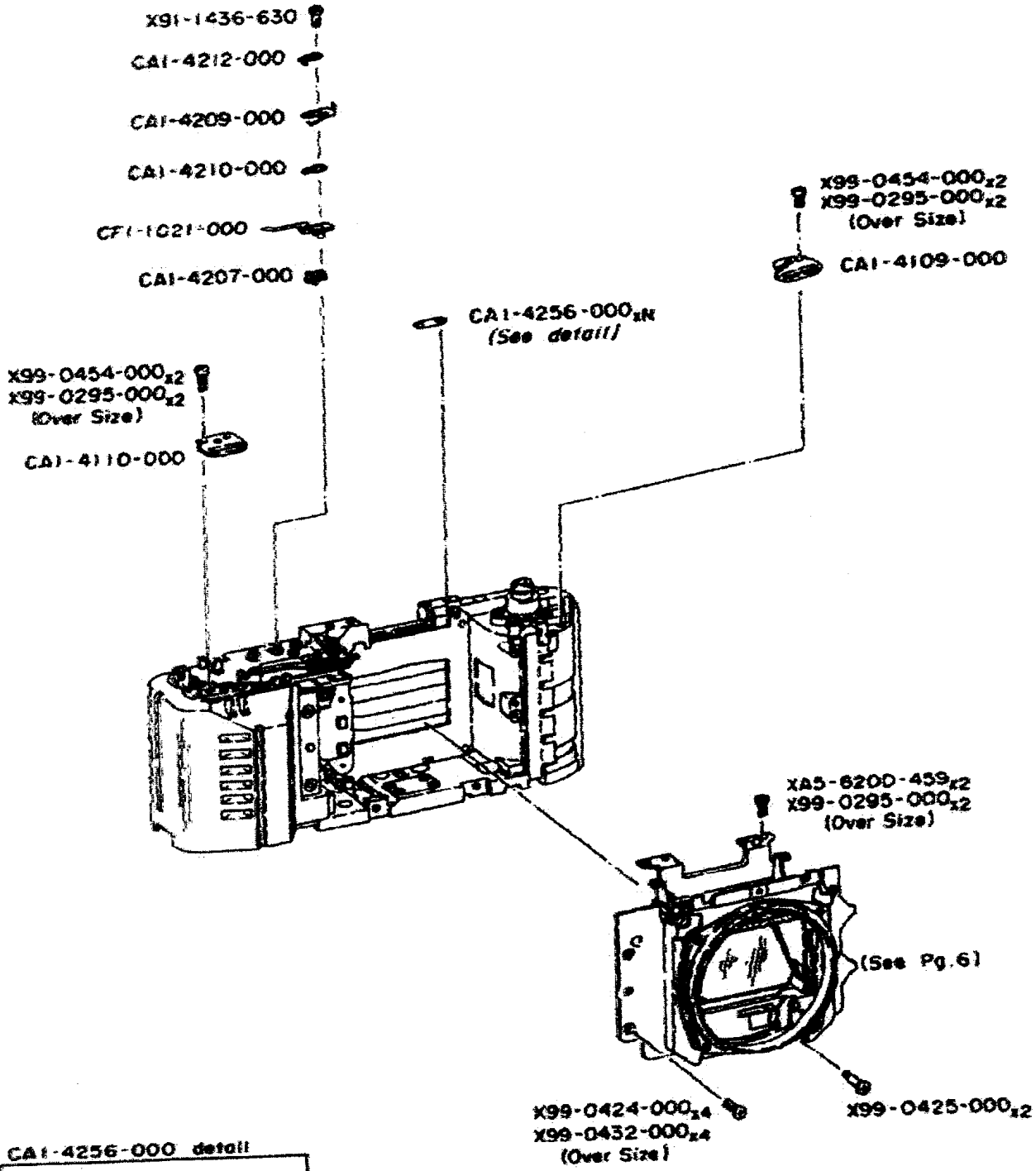

CA1-4256-000 detail

	A	SIZE
	0.03 mm	(010)
	0.05 mm	(020)

PARTS LIST



REWINO SW & NECK STRAP LUG PARTS

MARK	PART NO.	CLASS	QTY	DESCRIPTION
	CA1-4109-000	D	1	LUG, NECK STRAP
	CA1-4110-000	D	1	LUG, NECK STRAP
	CA1-4207-000	D	1	BASE, CONTACT
	CA1-4209-000	D	1	CONTACT, SW-R NO2
	CA1-4210-000	E	1	CONTACT, SPRING-1
	CA1-4212-000	E	1	CONTACT, SPRING-2
	CA1-4256-000	E	1	WASHER, ADJUSTING
	(ENTER SIZE WHEN ORDERING, SEE DETAIL)			
	CF1-1021-000	D	1	CONTACT, SW-R NO1
	XA5-6200-459		2	SCREW, CROSS-RECESS, PH
	X91-1436-630		1	SCREW, CROSS-RECESS, PH
	X99-0295-000		6	SCREW, CROSS-RECESS, PH
	X99-0424-000		4	SCREW, CROSS-RECESS, PH
	X99-0425-000		2	SCREW, CROSS-RECESS, PH
	X99-0432-000		4	SCREW, CROSS-RECESS, PH
	X99-0454-000		4	SCREW, CROSS-RECESS, PH

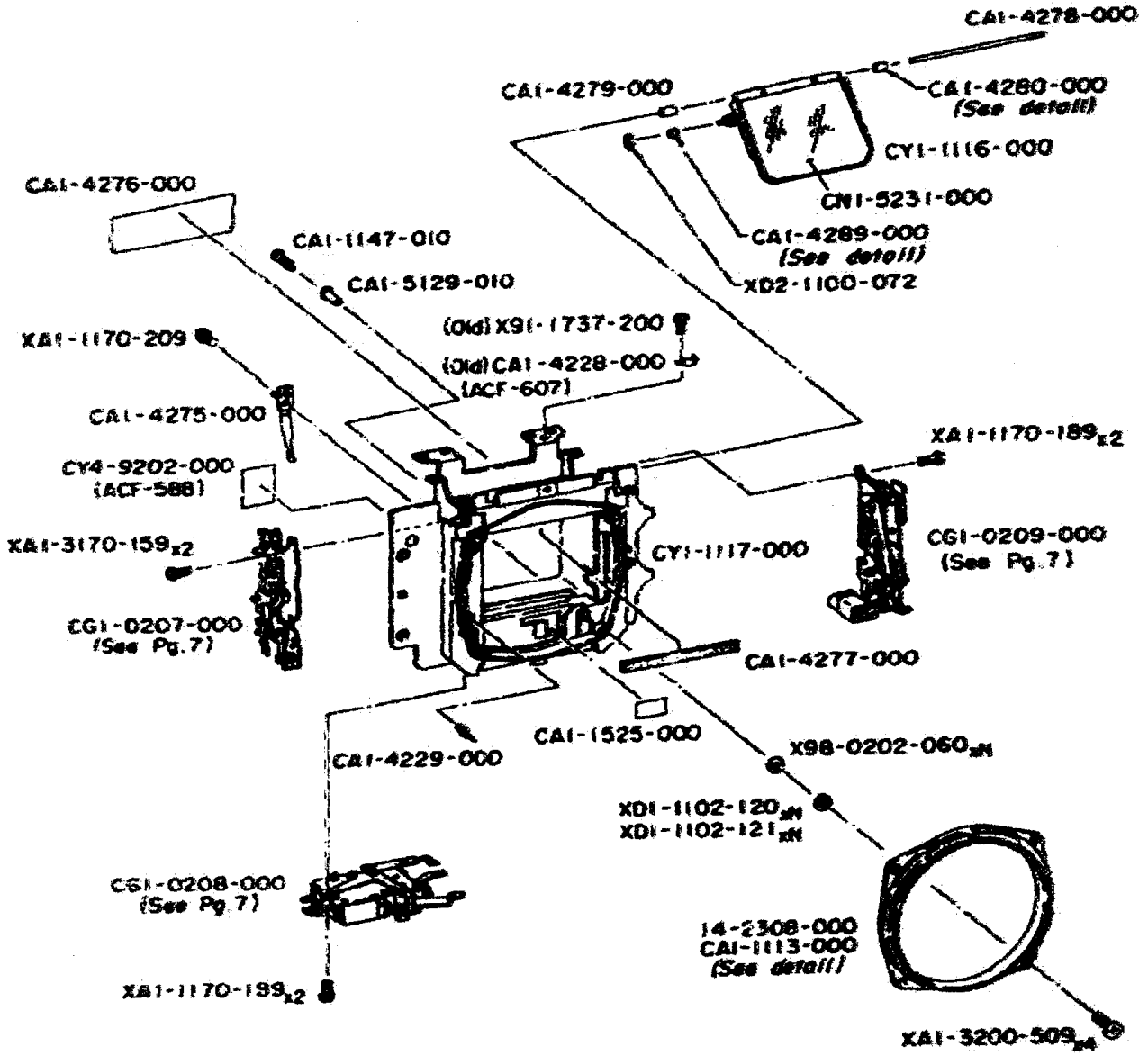



CANON T50





CAI-4280-000 detail

A	SIZE
	2.6 mm (010)
	2.7 mm (020)
	2.8 mm (030)

CAI-4289-000 detail

A	SIZE
	2.3 mm (05C)
	2.4 mm (050)
	2.5 mm (070)
	2.6 mm (080)

14-2308-000
CAI-1113-000 detail

A	SIZE
	14-2308-000 5.5mm - Standard
	CAI-1113-000 5.2mm - Special service part (0.3mm under standard)

PARTS LIST

MIRROR BOX UNIT PARTS

MARK	PART NO.	CLASS	QTY	DESCRIPTION
	14-2308-000	B	1	BODY, MOUNT
	CA1-1113-000	D	1	BODY, MOUNT
	CA1-1147-010	D	1	SCREW, MAX. APERTURE CORRECT.
	CA1-1525-000	B	1	SHIELD, LIGHT
	CA1-4228-000	D	1	LUG
	CA1-4229-000	E	1	PIN, A.M
	CA1-4275-000	D	1	CONTACT, A.M
	CA1-4276-000	E	1	SHIELD, LIGHT
	CA1-4277-000	D	1	CUSHION
	CA1-4278-000	E	1	SHAFT, MIRROR
	CA1-4279-000	E	1	COLLAR
	CA1-4280-000	E	1	COLLAR
	(ENTER SIZE WHEN ORDERING, SEE DETAIL)			
	CA1-4289-000	E	1	COLLAR
	(ENTER SIZE WHEN ORDERING, SEE DETAIL)			
	CA1-5129-000	D	1	PIN, MAX. APERTURE CORRECTION
	CNI-5231-000	C	1	MIRROR
	CY1-1116-000	D	1	MIRROR UNIT
	CY1-1117-000	E	1	FRONT PANEL ASSY
	CY4-9202-000		1	TAPE
	XA1-1170-189		4	SCREW, CROSS-RECESS, PH
	XA1-1170-209		1	SCREW, CROSS-RECESS, PH
	XA1-3170-159		2	SCREW, CROSS-RECESS, FCH
	XA1-3200-309		4	SCREW, CROSS-RECESS, FCH
	XD1-1102-120		1	WASHER
	XD1-1102-121		1	WASHER
	XD2-1100-072		1	E RING
	X91-1737-200		1	SCREW, CROSS-RECESS, PH
	X98-0202-060		1	WASHER

7

CANON T50

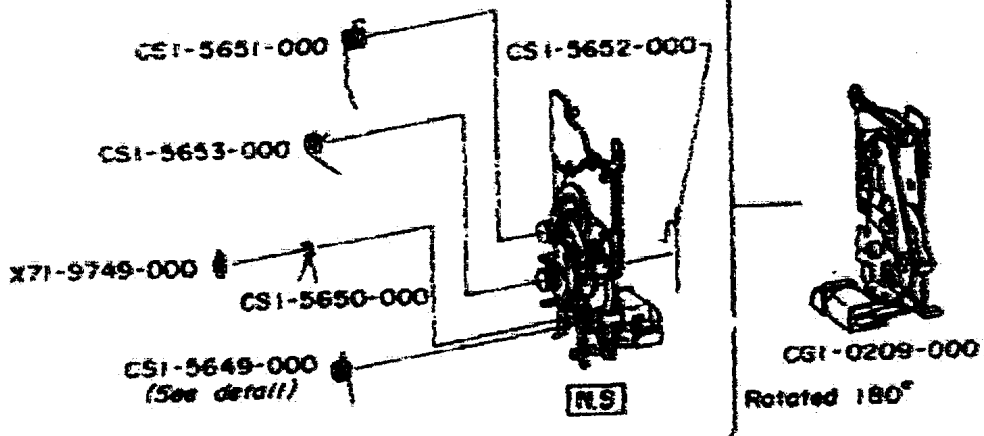
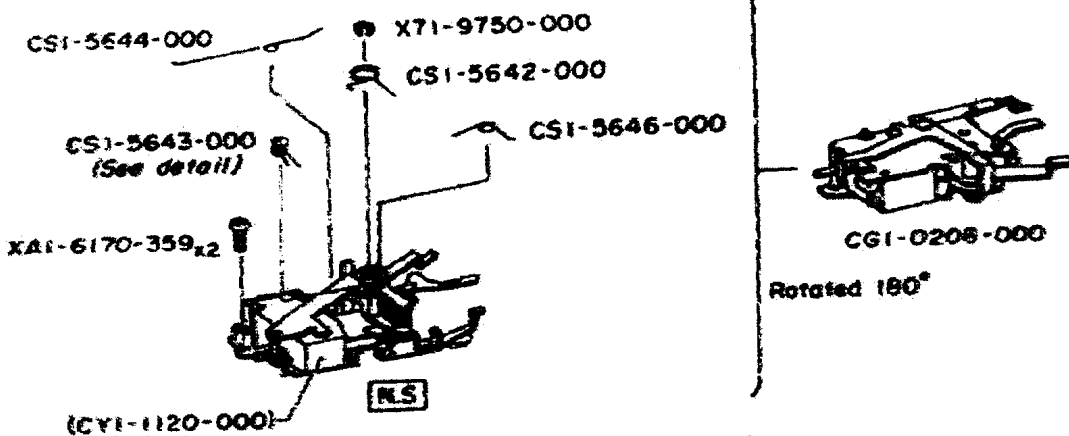
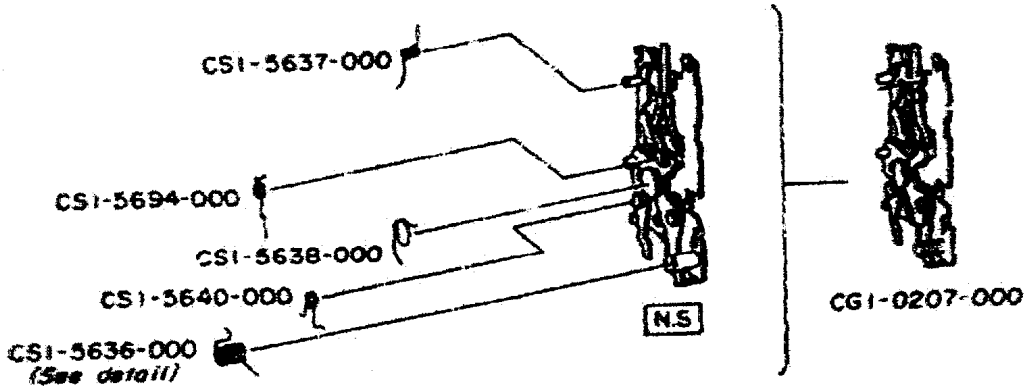

CSI-5636-000 detail

A	SIZE
105	(010)
175	(020)
180	(030)

CSI-5643-000 detail

A	SIZE
180	(010)
175	(020)
170	(030)
165	(040)

CSI-5649-000 detail

A	SIZE
146	(010)
151	(020)

PARTS LIST

MIRROR MECHANISM, AUTO DIAPHRAGM & AE UNIT

MARK	PART NO.	CLASS	QTY	DESCRIPTION
	CG1-0207-000	D	1	MIRROR MECHANISM
	CG1-0208-000	D	1	AUTO DIAPHRAGM UNIT
	CG1-0209-000	D	1	AE UNIT
	CS1-5636-000	E	1	SPRING
	(ENTER SIZE WHEN ORDERING, SEE DETAIL)			
	CS1-5637-000	E	1	SPRING
	CS1-5638-000	E	1	SPRING
	CS1-5640-000	E	1	SPRING
	CS1-5642-000	E	1	SPRING
	CS1-5643-000	E	1	SPRING
	(ENTER SIZE WHEN ORDERING, SEE DETAIL)			
	CS1-5644-000	E	1	SPRING
	CS1-5646-000	E	1	SPRING
	CS1-5649-000	E	1	SPRING
	(ENTER SIZE WHEN ORDERING, SEE DETAIL)			
	CS1-5650-000	E	1	SPRING
	CS1-5651-000	E	1	SPRING
	CS1-5652-000	E	1	SPRING
	CS1-5653-000	E	1	SPRING
	CS1-5694-000	E	1	SPRING
	CY1-1120-000	E	1	MAGNET NO.2 UNIT
	XA1-6170-359		2	SCREW, CROSS-RECESS, PH
	X71-9749-000	B		RETAINER
	X71-9750-000		1	RETAINER

CANON T50

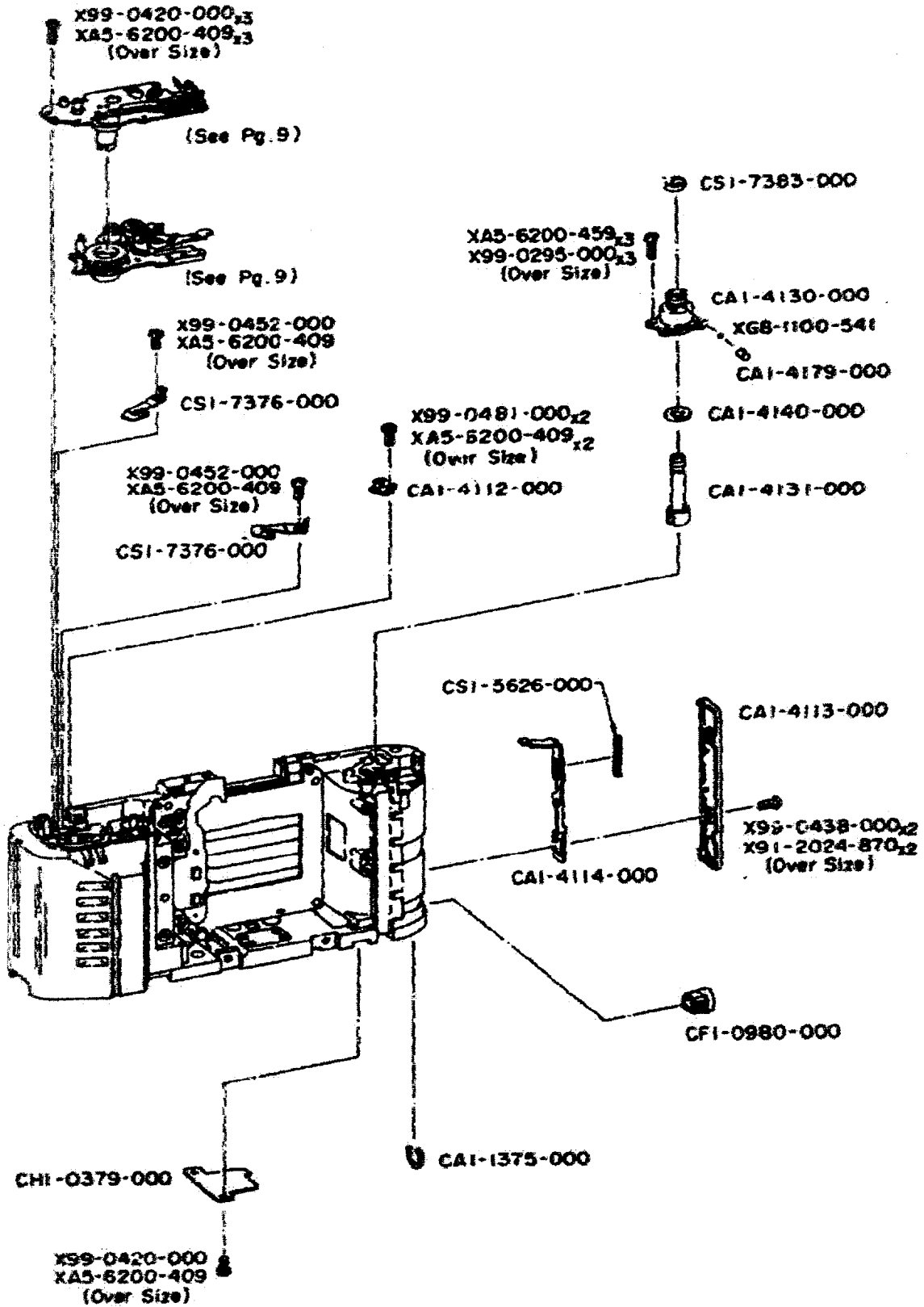

PARTS LIST

PRINTED CIRCUIT BOARD & REWINDING PARTS

MARK	PART NO.	CLASS	QTY	DESCRIPTION
	CA1-1375-000	C	1	C RING
	CA1-4112-000	D	1	HOLDER
	CA1-4113-000	C	1	COVER, RIGHT FRONT
	CA1-4114-000	E	1	HOOK
	CA1-4130-000	E	1	HOLDER, REWIND SHAFT
	CA1-4131-000	B	1	SHAFT, REWIND
	CA1-4140-000	D	1	COVER, SHAFT
	CA1-4179-000	D	1	ROLLER
	CF1-0980-000	E	1	REMOTECONTROL JACK UNIT
	CM1-0379-000	C	1	BOARD, PRINTED CIRCUIT
	CS1-5626-000	D	1	SPRING
	CS1-7376-000	C	2	CONTACT
	CS1-7383-000	D	1	SPRING, CLICK
	XAS-6200-409		8	SCREW, CROSS-RECESS, PH
	XAS-6200-459		3	SCREW, CROSS-RECESS, PH
	XG6-1100-541	E	1	BALL, STEEL
	X91-2024-870		2	SCREW, CROSS-RECESS, PH
	X99-0295-000		3	SCREW, CROSS-RECESS, PH
	X99-0420-000		4	SCREW, CROSS-RECESS, PH
	X99-0438-000		2	SCREW, CROSS-RECESS, PH
	X99-0452-000		2	SCREW, CROSS-RECESS, PH
	X99-0481-000		2	SCREW, CROSS-RECESS, PH

CANON T50

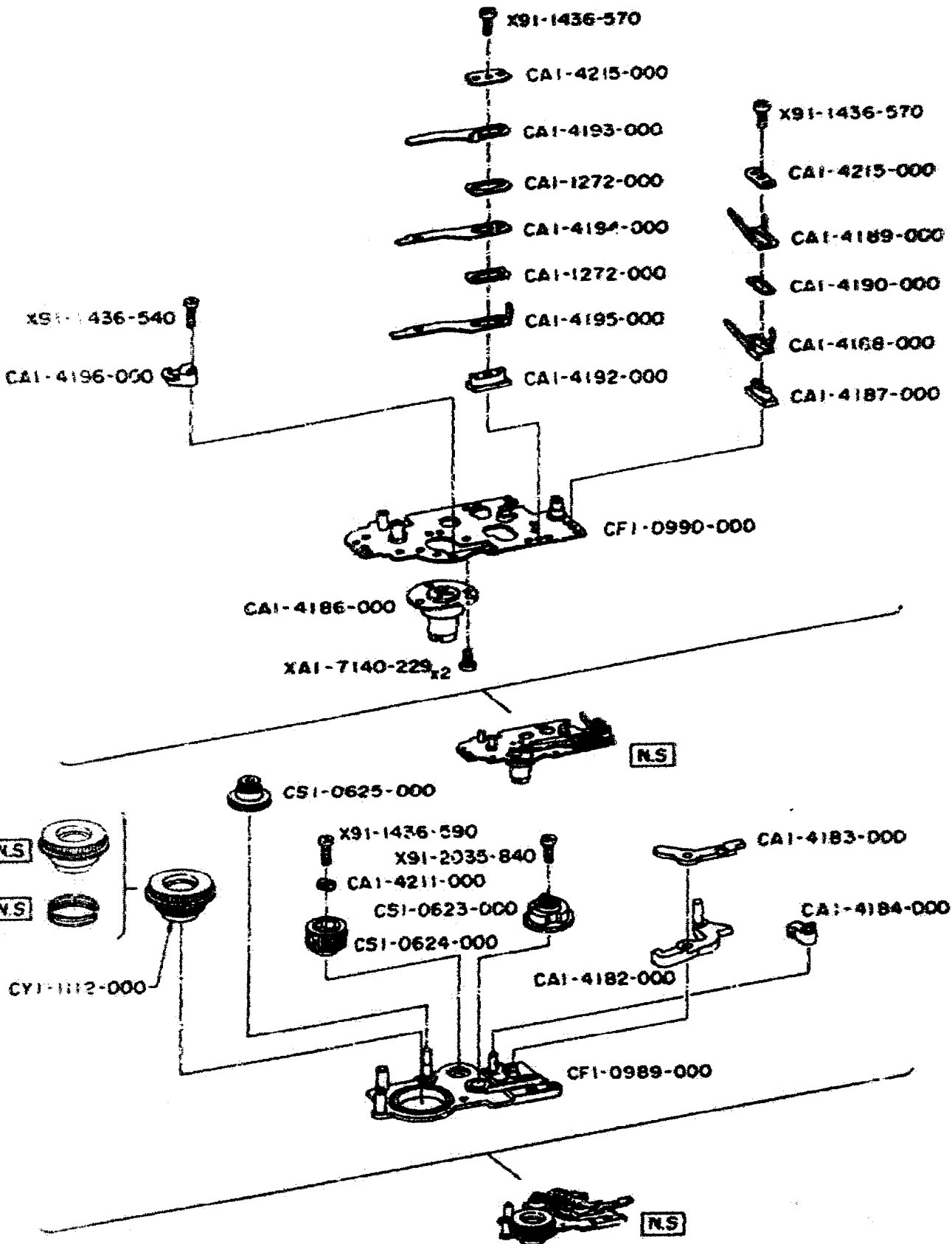

PARTS LIST

SWITCH & GEAR MECHANISM

MARK	PART NO.	CLASS	QTY	DESCRIPTION
	CA1-1272-000	E	2	INSULATOR
	CA1-4182-000	E	1	LEVER, WINDING STOPPER
	CA1-4183-000	E	1	LEVER, MIRROR RETURNING
	CA1-4184-000	E	1	LEVER, RETURNING STOPPER
	CA1-4186-000	E	1	HOLDER, MOTOR
	CA1-4187-000	D	1	BASE, CONTACT
	CA1-4188-000	D	1	CONTACT, SW4-1
	CA1-4189-000	D	1	CONTACT, SW4-2
	CA1-4190-000	D	1	INSULATOR
	CA1-4192-000	D	1	BASE, CONTACT
	CA1-4193-000	D	1	CONTACT, RELEASE-1
	CA1-4194-000	D	1	CONTACT, RELEASE-2
	CA1-4195-000	D	1	CONTACT, RELEASE-3
	CA1-4196-000	D	1	BASE, CONTACT
	CA1-4211-000	E	1	COUPLER, SPROCKET
	CA1-4215-000	D	2	INSULATOR
	CF1-0989-000	E	1	BASEPLATE, UPPER WINDING-1
	CF1-0990-000	E	1	BASEPLATE, UPPER WINDING-2
	CS1-0623-000	E	1	GEAR
	CS1-0624-000	E	1	GEAR
	CS1-0625-000	E	1	GEAR
	CY1-1112-000	D	1	SPOOL GEAR ASSY
	XA1-7140-229		2	SCREW, CROSS-RECESS, PH
	X91-1436-340		1	SCREW, CROSS-RECESS, PH
	X91-1436-57D		2	SCREW, CROSS-RECESS, PH
	X91-1436-59D		1	SCREW, CROSS-RECESS, PH
	X91-2035-34D		1	SCREW, CROSS-RECESS, PH

CANON T50

CAI-4175-000
 CAI-4175-020 detail ACF-542

Old → New

Old and new parts are not interchangeable
 Camera Service stocks the old and new parts
 See also CAI-4175-000 related change
 (See Pg. 11)

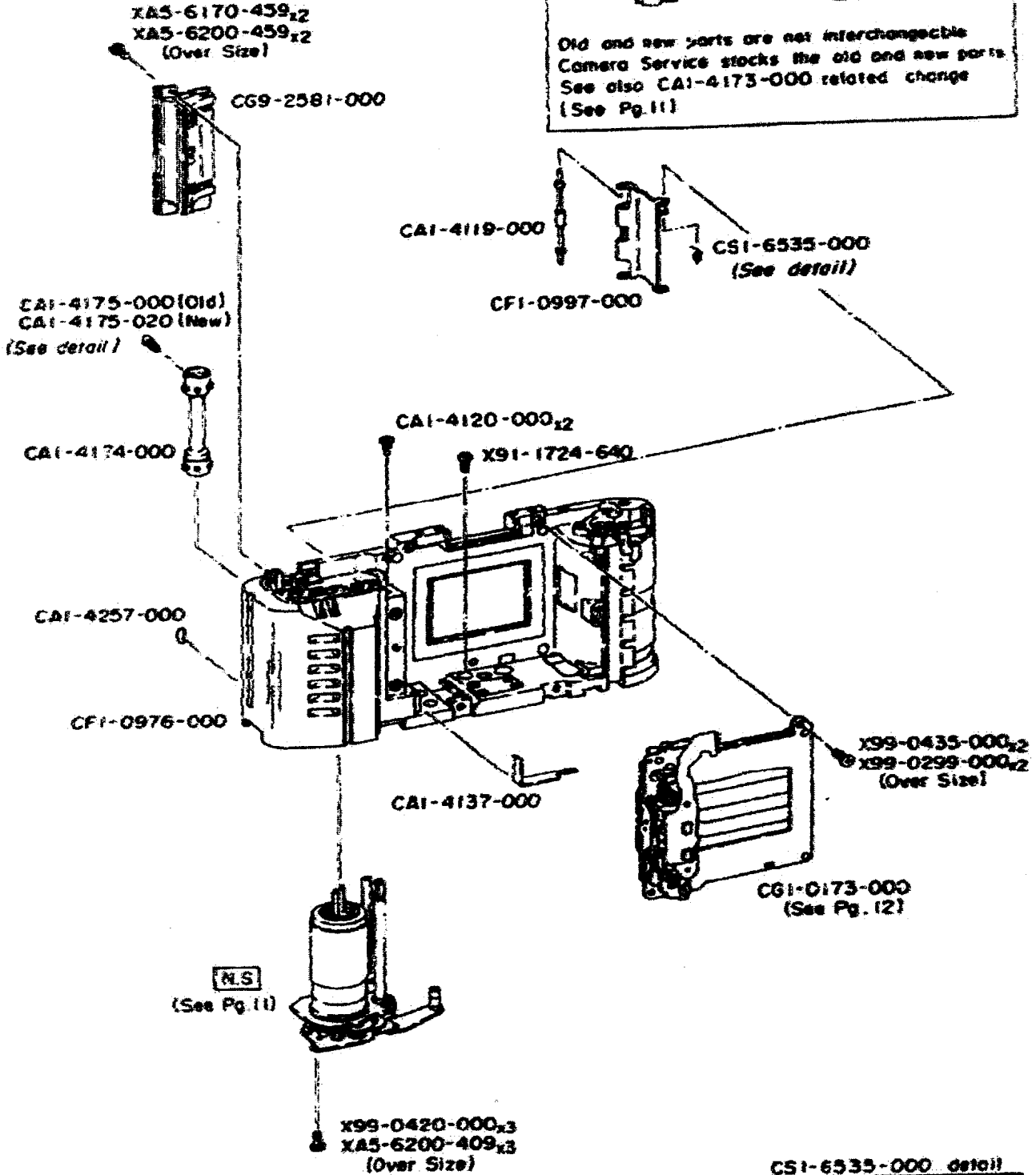

CS1-6535-000 detail

A	A	SIZE
	110°	(110)
	115°	(115)

PARTS LIST

SPROCKET & SHUTTER UNIT

MARK	PART NO.	CLASS	QTY	DESCRIPTION
	CA1-4119-000	E	1	ROLLER, AL
	CA1-4120-000	D	2	SCREW, SHAFT
	CA1-4137-000	D	1	SHIELD, LIGHT
	CA1-4174-000	C	1	SPROCKET
	CA1-4175-000	D	1	SCREW
	CA1-4175-020	D	1	SCREW
	CA1-4257-000	D	1	SEAL, FILM
	CF1-0976-000	E	1	BODY
	CF1-0997-000	D	1	COVER, AL
	CG9-2581-000	D	1	ROLLER HOLDER UNIT
	CS1-6535-000	E	1	SPRING
	(ENTER SIZE WHEN ORDERING, SEE DETAIL)			
	XAS-6170-459		2	SCREW, CROSS-RECESS, PH
	XAS-6200-409		3	SCREW, CROSS-RECESS, PH
	XAS-6200-459		2	SCREW, CROSS-RECESS, PH
	X91-1724-640		1	SCREW, CROSS-RECESS, PH
	X99-0299-000		2	SCREW, CROSS-RECESS, FCH
	X99-0420-000		3	SCREW, CROSS-RECESS, PH
	X99-0435-000		2	SCREW, CROSS-RECESS, FCH

CANON T50

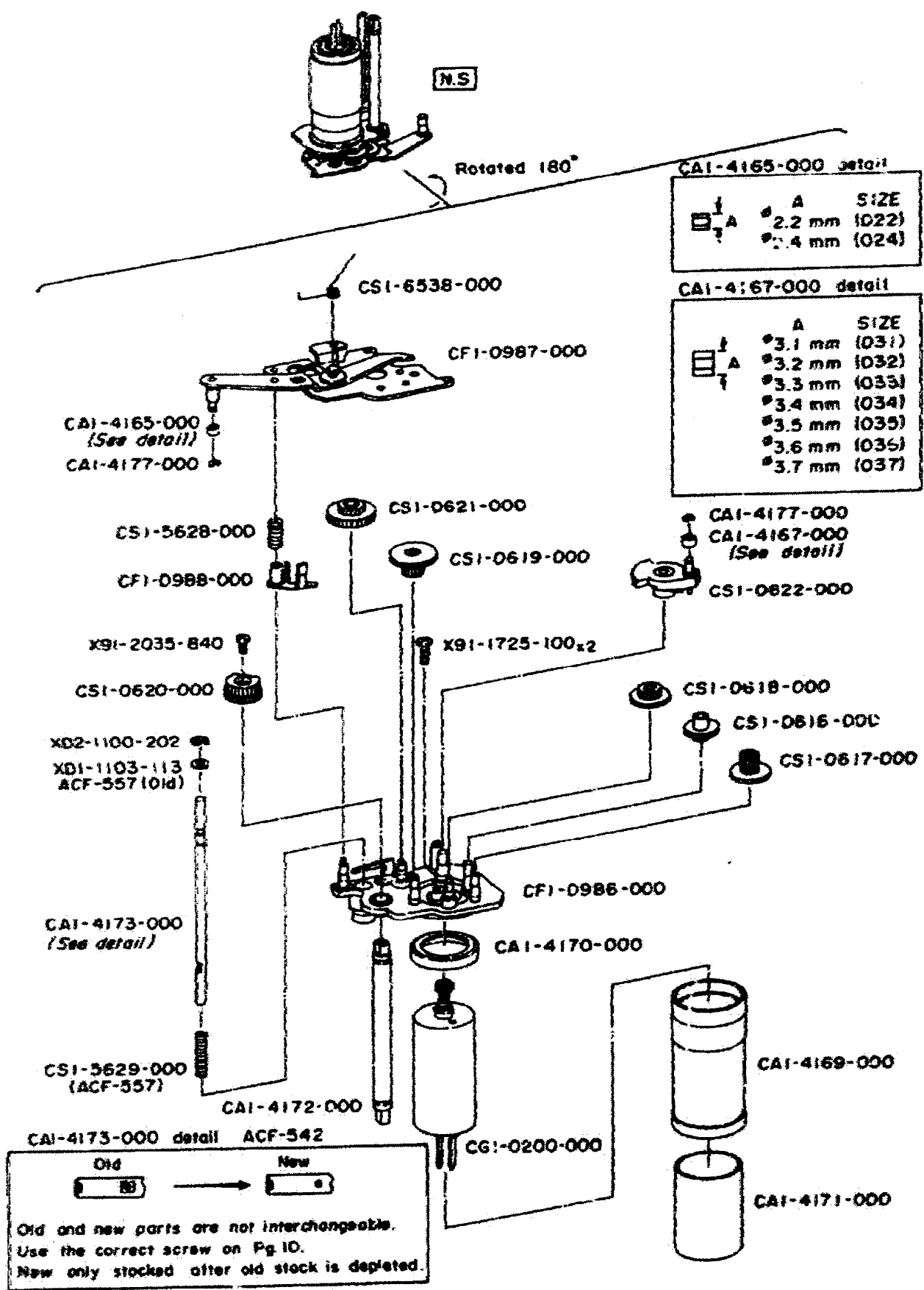

PARTS LIST

MOTOR & GEAR MECHANISM

MARK	PART NO.	CLASS	QTY	DESCRIPTION
	CA1-4165-000 (ENTER SIZE WHEN ORDERING, SEE DETAIL)	E	1	COLLAR, CHARGE
	CA1-4167-000 (ENTER SIZE WHEN ORDERING, SEE DETAIL)	E	1	COLLAR, SECTOR
	CA1-4169-000	E	1	SPOOL
	CA1-4170-000	E	1	COLLAR, SPOOL
	CA1-4171-000	D	1	RUBBER, SPOOL
	CA1-4172-000	E	1	SHAFT, WINDING
	CA1-4173-000	D	1	SHAFT, SPROCKET
	CA1-4177-000	D	2	C RING
	CF1-0986-000	E	1	BASEPLATE, LOWER WINDING-1
	CF1-0987-000	E	1	BASEPLATE, LOWER WINDING-2
	CF1-0988-000	E	1	LEVER, LOCK
	CG1-0200-000	D	1	MOTOR UNIT
	CS1-0616-000	E	1	GEAR
	CS1-0617-000	E	1	GEAR
	CS1-0618-000	E	1	GEAR
	CS1-0619-000	E	1	GEAR
	CS1-0620-000	E	1	GEAR
	CS1-0621-000	E	1	GEAR
	CS1-0622-000	E	1	GEAR, SECTOR
	CS1-5628-000	E	1	SPRING, COIL
	CS1-5629-000	E	1	SPRING, COIL
	CS1-6538-000	E	1	SPRING
	X01-1103-113		1	WASHER
	XD2-1100-202		1	E RING
	X91-1725-100		2	SCREW, CROSS-RECESS, PH
	X91-2035-840		1	SCREW, CROSS-RECESS, PH

CANON T50

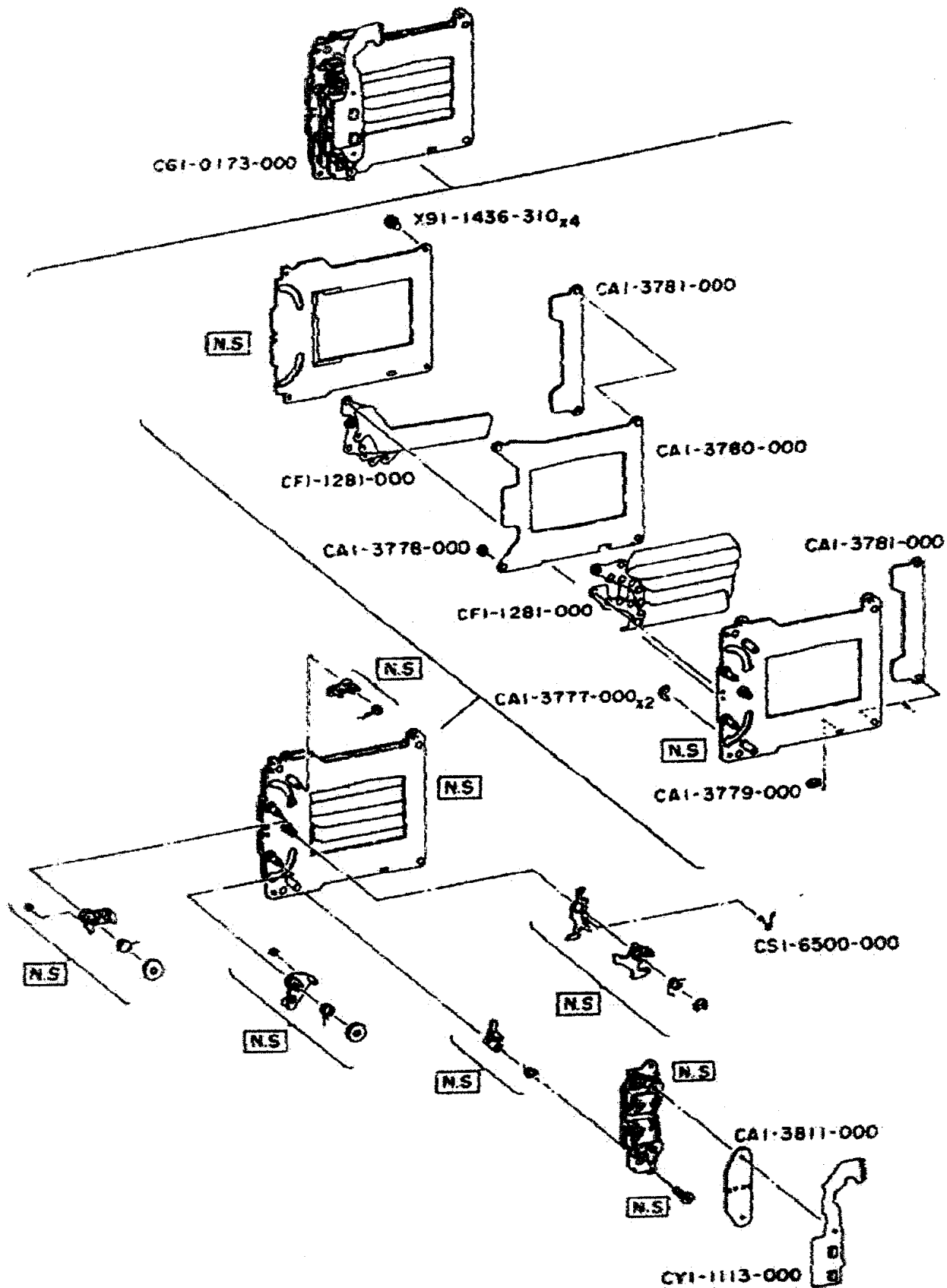

PARTS LIST

SHUTTER PARTS

MARK	PART NO.	CLASS	QTY	DESCRIPTION
	CA1-3777-000	E	2	RUBBER, STOPPER
	CA1-3778-000	E	1	RUBBER, STOPPER-A
	CA1-3779-000	E	1	RUBBER, STOPPER-B
	CA1-3780-000	E	1	PLATE, SEPARATOR
	CA1-3781-000	E	2	SPACER
	CA1-3811-000	E	1	PLATE, CONTACT POSITIONING
	CF1-1281-000	C	2	SHUTTER BLADE UNIT
	CG1-0173-000	C	1	SHUTTER UNIT
	CS1-6500-000	D	1	SPRING
	CY1-1113-000	C	1	SHUTTER FLEX PCB P.H
	X91-1436-310		4	SCREW, CROSS-RECESS, PH

CANON T50

ELECTRIC PARTS UNIT (2nd Type) WIRING DIAGRAM (Back View)

REF. NO C12-1632

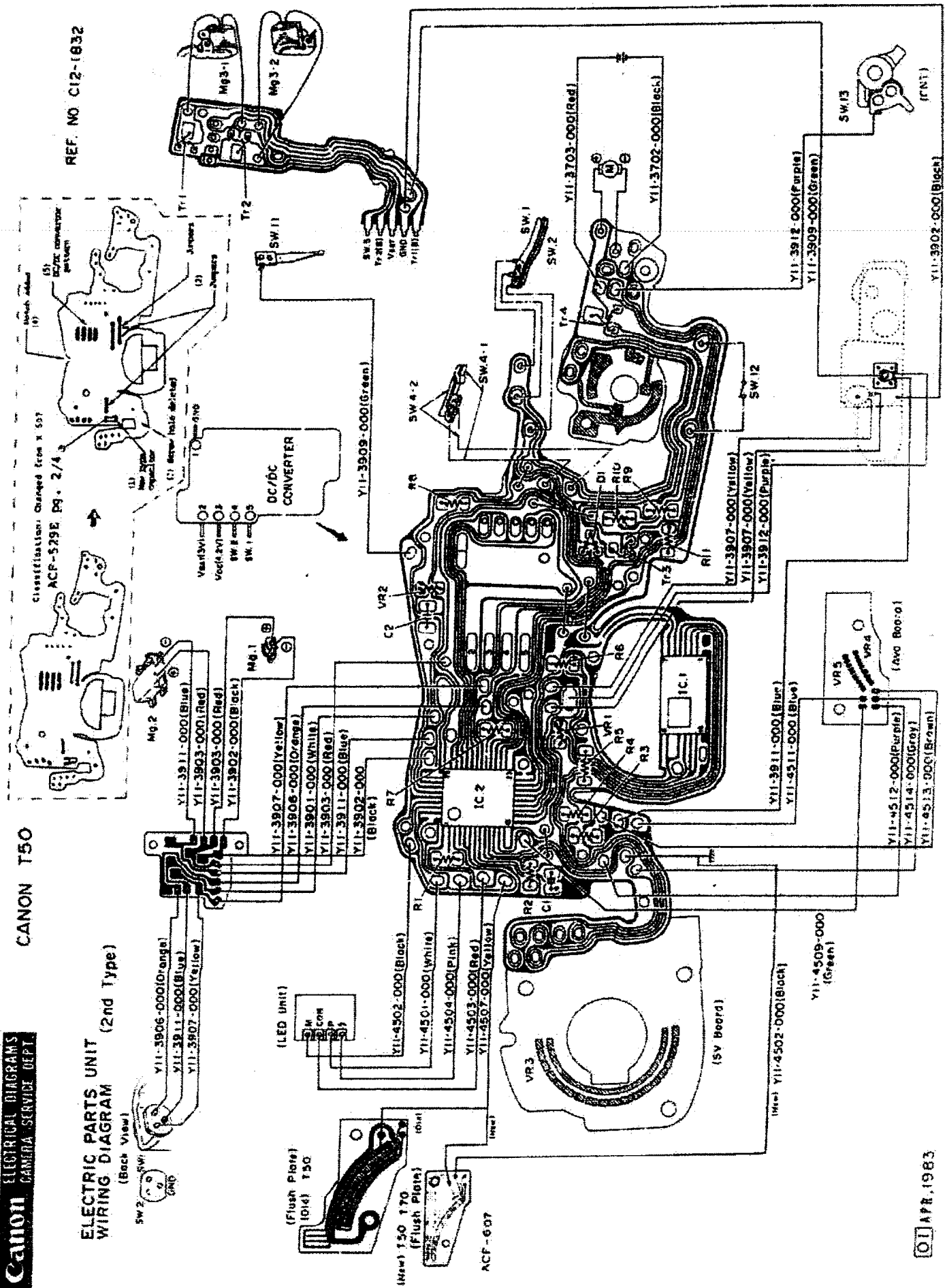

01 APR. 1983

114

CONTENTS

	Page	Address
1. Release Inoperative	1	E-10
2. No VDC Output	2	E-11
3. Takeup Mechanism Inoperative	3	E-12
4. 1/1000 Setting not Adjustable	4	E-13
5. 1st Curtain doesn't Travel	5	E-14
6. 2nd Curtain doesn't Travel	6	F-1
7. Level Adjustment not Possible	7	F-2
8. Aperture Set to Minimum During AE	8	F-3
9. Aperture Fully Open During AE	9	F-4
10. Self Timer doesn't Operate	10	F-5
11. Remote Control not Possible	11	F-6
12. CNT Inoperative	12	F-7
13. Inhibit Voltage Incorrect	13	F-8
14. Leak Current	14	F-9
15. "P" in Viewfinder doesn't Light	15	F-10
16. "⚡" in Viewfinder doesn't Light	16	F-11
17. "M" in Viewfinder doesn't Light	17	F-12

1. Release Inoperative

(DV: Use digital voltmeter, SY: Use synchroscope)

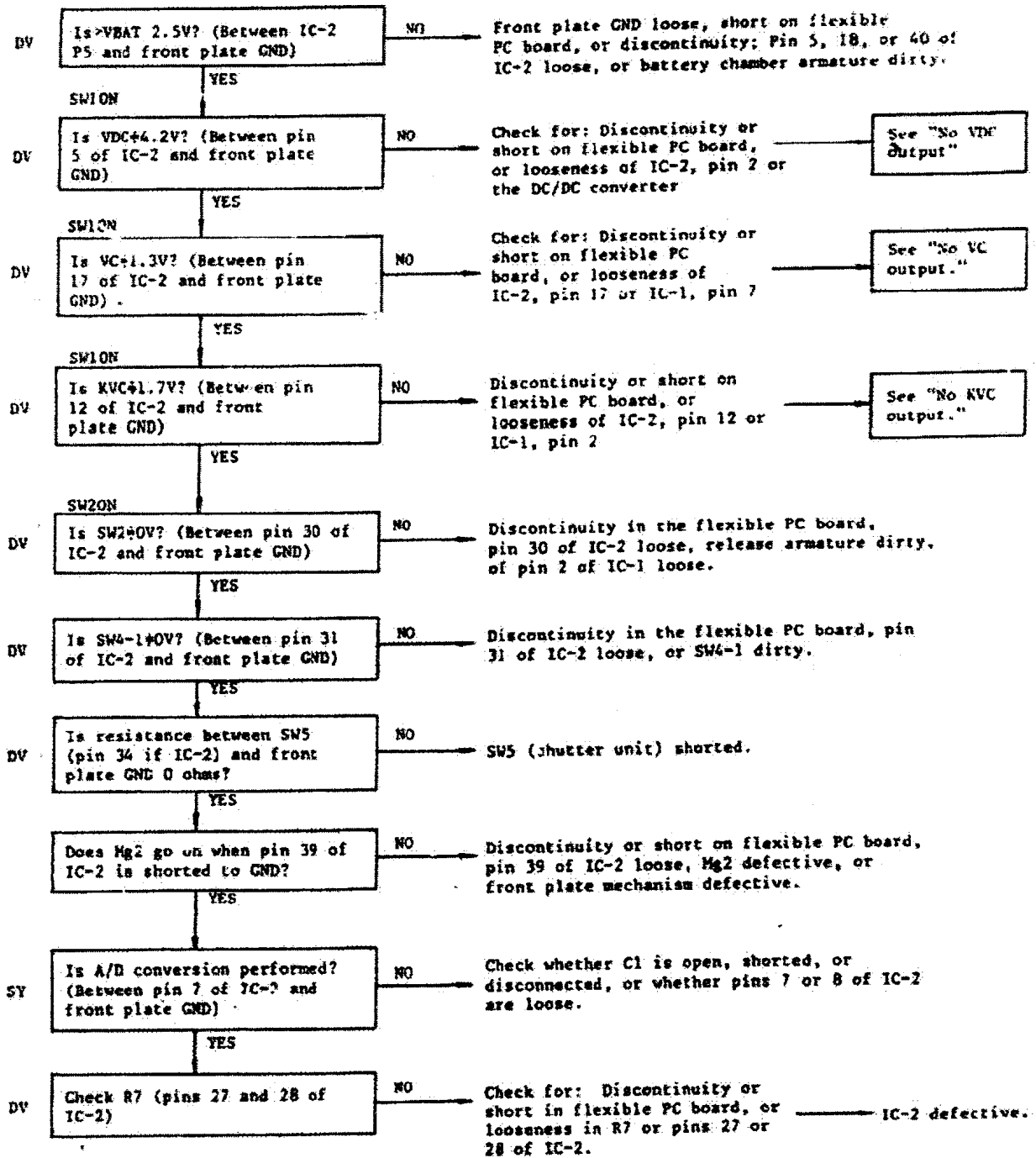

**ELECTRIC PARTS UNIT
WIRING DIAGRAM**

CANON T50

REF. NO. C12-1832

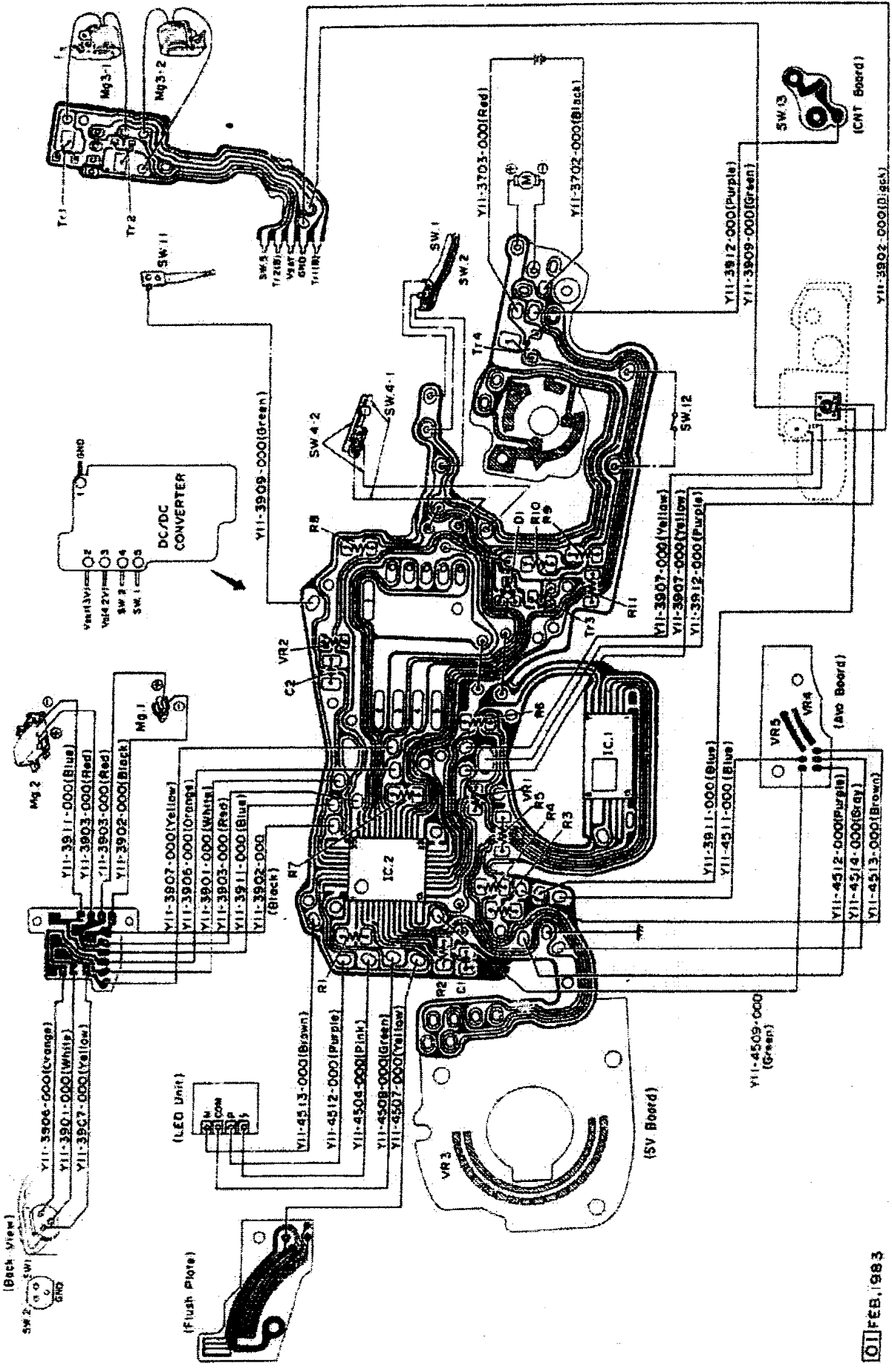

01 FEB. 1983

15

PARTS LIST

ELECTRIC PARTS & LEADS

SYMBOL	PART NO.	CLASS	DESCRIPTION	REMARKS
C1			CAPACITOR, CERA	0.01uF 25V
C2			CAPACITOR, TANTA	1uF 20V
Q1			DIODE	MA151WA
DC/DC	CH3-0015-000	D	CONVERTER, DC-DC	
IC1	CH4-0105-000	C	IC	T2682B
IC2	CH4-0090-000	C	IC	T1513
R1	VR9-1099-000	E	RESISTOR	22 KOHM, 1/8W
	VR9-1887-000	E	RESISTOR	24 KOHM, 1/8W
	VR9-1888-000	E	RESISTOR	27 KOHM, 1/8W
	VR9-1889-000	E	RESISTOR	30 KOHM, 1/8W
	VR9-1103-000	E	RESISTOR	33 KOHM, 1/8W
	VR9-1891-000	E	RESISTOR	36 KOHM, 1/8W
	VR9-1892-000	E	RESISTOR	39 KOHM, 1/8W
	VR9-1893-000	E	RESISTOR	43 KOHM, 1/8W
	VR9-1753-000	E	RESISTOR	47 KOHM, 1/8W
	VR9-1476-000	E	RESISTOR	51 KOHM, 1/8W
	VR9-1896-000	E	RESISTOR	62 KOHM, 1/8W
R2	VR9-1095-000	E	RESISTOR	15 KOHM, 1/8W
	VR9-1097-000	E	RESISTOR	18 KOHM, 1/8W
	VR9-1886-000	E	RESISTOR	20 KOHM, 1/8W
	VR9-1099-000	E	RESISTOR	22 KOHM, 1/8W
	VR9-1887-000	E	RESISTOR	24 KOHM, 1/8W
	VR9-1888-000	E	RESISTOR	27 KOHM, 1/8W
	VR9-1889-000	E	RESISTOR	30 KOHM, 1/8W
	VR9-1103-000	E	RESISTOR	33 KOHM, 1/8W
	VR9-1891-000	E	RESISTOR	36 KOHM, 1/8W
	VR9-1892-000	E	RESISTOR	39 KOHM, 1/8W
R3	VR9-2291-000	E	RESISTOR	19.6 KOHM 1/8W
R4	VR9-1870-000	E	RESISTOR	3.32 KOHM 1/8W
	VR9-1871-000	E	RESISTOR	3.40 KOHM 1/8W
	VR9-1872-000	E	RESISTOR	3.48 KOHM 1/8W
	VR9-1873-000	E	RESISTOR	3.55 KOHM 1/8W
	VR9-1874-000	E	RESISTOR	3.63 KOHM 1/8W
	VR9-1875-000	E	RESISTOR	3.74 KOHM 1/8W
	VR9-1876-000	E	RESISTOR	3.83 KOHM 1/8W
	VR9-1877-000	E	RESISTOR	3.92 KOHM 1/8W
R5	CH9-0055-000	E	RESISTOR	2.0 KOHM 1/8W
	VR9-1099-000	E	RESISTOR	22 KOHM 1/8W
	VR9-1103-000	E	RESISTOR	33 KOHM 1/8W
	VR9-1109-000	E	RESISTOR	56 KOHM 1/8W
	VR9-1115-000	E	RESISTOR	100 KOHM 1/8W

PARTS LIST

ELECTRIC PARTS & LEADS

SYMBOL	PART NO.	CLASS	DESCRIPTION	REMARKS	
R7	VR9-1321-000	E	RESISTOR	178 KOHM 1/8W	
	VR9-1322-000	E	RESISTOR	187 KOHM 1/8W	
	VR9-1323-000	E	RESISTOR	196 KOHM 1/8W	
	VR9-1413-000	E	RESISTOR	205 KOHM 1/8W	
	VR9-1414-000	E	RESISTOR	215 KOHM 1/8W	
	VR9-1415-000	E	RESISTOR	226 KOHM 1/8W	
	VR9-1416-000	E	RESISTOR	237 KOHM 1/8W	
	VR9-1417-000	E	RESISTOR	249 KOHM 1/8W	
	VR9-1418-000	E	RESISTOR	261 KOHM 1/8W	
	VR9-1419-000	E	RESISTOR	274 KOHM 1/8W	
	VR9-1420-000	E	RESISTOR	287 KOHM 1/8W	
	VR9-1421-000	E	RESISTOR	301 KOHM 1/8W	
	VR9-2367-000	E	RESISTOR	316 KOHM 1/8W	
	VR9-2368-000	E	RESISTOR	332 KOHM 1/8W	
	VR9-2369-000	E	RESISTOR	348 KOHM 1/8W	
	VR9-2370-000	E	RESISTOR	365 KOHM 1/8W	
	R8	VR9-1087-000	E	RESISTOR	6.8 KOHM 1/8W
	R9	VR9-1324-000	E	RESISTOR	470 OHM 1/8W
	R10	VR9-2293-000	E	RESISTOR	2.0 KOHM 1/8W
R11	VR9-2292-000	E	RESISTOR	20 OHM 1/8W	
TR1			TRANSISTOR	25C2982	
TR2			TRANSISTOR	25C2982	
TR3	WA2-0228-000	E	TRANSISTOR	25C2712	
TR4	WA2-0213-000	D	TRANSISTOR	2SA1213 Q/Y	
VR1	VR9-1125-000	E	RESISTOR, VARIABLE	220 KOHM	
VR2	CH9-0072	E	RESISTOR, VARIABLE	333 KOHM	
VR3					
VR4					
VR5					
	Y11-3702-000		LEAD (BLACK)		
	Y11-3703-000		LEAD (RED)		
	Y11-3901-000		LEAD (WHITE)		
	Y11-3902-000		LEAD (BLACK)		
	Y11-3903-000		LEAD (RED)		
	Y11-3906-000		LEAD (ORANGE)		
	Y11-3907-000		LEAD (YELLOW)		
	Y11-3909-000		LEAD (GREEN)		
	Y11-3911-000		LEAD (BLUE)		
	Y11-3912-000		LEAD (PURPLE)		
	Y11-4501-000		LEAD (WHITE)		
	Y11-4502-000		LEAD (BLACK)		
	Y11-4503-000		LEAD (RED)		
	Y11-4506-000		LEAD (ORANGE)		
	Y11-4507-000		LEAD (YELLOW)		
	Y11-4509-000		LEAD (GREEN)		
	Y11-4511-000		LEAD (BLUE)		
	Y11-4512-000		LEAD (PURPLE)		
	Y11-4513-000		LEAD (BROWN)		
	Y11-4514-000		LEAD (GRAY)		

INDEX OF PARTS NUMBERS

NEW	PART NO.	PAGE	ADDRESS	NEW	PART NO.	PAGE	ADDRESS
	10-4233-000	4	A-13,14		CA1-4194-000	9	B-9,10
	14-2308-000	6	9-3,4		CA1-4155-000	9	B-9,10
	CA1-1113-000	6	B-3,4		CA1-4196-000	9	B-9,10
	CA1-1147-010	6	B-3,4		CA1-4203-000	3	A-11,12
	CA1-1272-000	9	B-9,10		CA1-4204-000	3	A-11,12
	CA1-1374-000	2	A-9,10		CA1-4205-000	3	A-11,12
	CA1-1375-000	8	B-7,8		CA1-4206-000	3	A-11,12
	CA1-1525-000	6	B-3,4		CA1-4207-000	5	B-1,2
	CA1-3385-000	2	A-9,10		CA1-4209-000	5	B-1,2
	CA1-3777-000	12	C-1,2		CA1-4210-000	5	B-1,2
	CA1-3778-000	12	C-1,2		CA1-4211-000	9	B-9,10
	CA1-3779-000	12	C-1,2		CA1-4212-000	5	B-1,2
	CA1-3780-000	12	C-1,2		CA1-4214-000	2	A-9,10
	CA1-3781-000	12	C-1,2		CA1-4215-000	9	B-9,10
	CA1-3811-000	12	C-1,2		CA1-4219-000	4	A-13,14
	CA1-4102-000	1	A-7,8		CA1-4220-000	4	A-13,14
	CA1-4103-000	1	A-7,8		CA1-4221-000	4	A-13,14
	CA1-4104-000	1	A-7,8		CA1-4226-000	4	A-13,14
	CA1-4108-000	1	A-7,8		CA1-4227-000	4	A-13,14
	CA1-4139-000	5	B-1,2		CA1-4227-030	4	A-13,14
	CA1-4110-000	5	B-1,2		CA1-4228-000	6	B-3,4
	CA1-4112-000	8	B-7,8		CA1-4229-000	6	B-3,4
	CA1-4113-000	8	B-7,8		CA1-4230-000	1	A-7,8
	CA1-4114-000	8	B-7,8		CA1-4232-000	2	A-9,10
	CA1-4119-000	10	B-11,12		CA1-4233-000	2	A-9,10
	CA1-4120-000	10	B-11,12		CA1-4234-000	2	A-9,10
	CA1-4125-000	3	A-11,12		CA1-4235-000	2	A-9,10
	CA1-4138-000	8	B-7,8		CA1-4236-000	2	A-9,10
	CA1-4131-000	8	B-7,8		CA1-4237-000	2	A-9,10
	CA1-4133-000	4	A-13,14		CA1-4238-000	2	A-9,10
	CA1-4135-000	1	A-7,8		CA1-4239-000	2	A-9,10
	CA1-4137-000	10	B-11,12		CA1-4243-000	2	A-9,10
	CA1-4139-000	3	A-11,12		CA1-4244-000	2	A-9,10
	CA1-4140-000	8	B-7,8		CA1-4248-000	3	A-11,12
	CA1-4141-000	1	A-7,8		CA1-4249-000	3	A-11,12
	CA1-4144-000	1	A-7,8		CA1-4256-000	5	B-1,2
	CA1-4145-000	1	A-7,8		CA1-4257-000	10	B-11,12
	CA1-4154-000	3	A-11,12		CA1-4275-000	6	B-3,4
	CA1-4156-000	3	A-11,12		CA1-4276-000	6	B-3,4
	CA1-4157-000	3	A-11,12		CA1-4277-000	6	B-3,4
	CA1-4158-000	3	A-11,12		CA1-4278-000	6	B-3,4
	CA1-4165-000	11	B-13,14		CA1-4279-000	6	B-3,4
	CA1-4167-000	11	B-13,14		CA1-4280-000	6	B-3,4
	CA1-4169-000	11	B-13,14		CA1-4289-000	6	B-3,4
	CA1-4170-000	11	B-13,14		CA1-4848-000	4	A-13,14
	CA1-4171-000	11	B-13,14		CA1-4959-000	3	A-11,12
	CA1-4172-000	11	B-13,14		CA1-5129-010	6	B-3,4
	CA1-4173-000	11	B-13,14		CA1-5133-000	4	A-13,14
	CA1-4174-000	10	B-11,12				
	CA1-4175-000	10	B-11,12		CAA-1847-000	1	A-7,8
	CA1-4175-020	10	B-11,12				
	CA1-4177-000	11	B-13,14		CF1-0423-000	3	A-11,12
	CA1-4178-000	1	A-7,8		CF1-0976-000	10	B-11,12
	CA1-4179-000	8	B-7,8		CF1-0977-000	1	A-7,8
	CA1-4182-000	9	B-9,10		CF1-0980-000	8	B-7,8
	CA1-4183-000	9	B-9,10		CF1-0981-000	4	A-13,14
	CA1-4184-000	9	B-9,10		CF1-0982-000	3	A-11,12
	CA1-4186-000	9	B-9,10		CF1-0986-000	11	B-13,14
	CA1-4187-000	9	B-9,10		CF1-0987-000	11	B-13,14
	CA1-4188-000	9	B-9,10		CF1-0988-000	11	B-13,14
	CA1-4189-000	9	B-9,10		CF1-0989-000	9	B-9,10
	CA1-4190-000	9	B-9,10		CF1-0990-000	9	B-9,10
	CA1-4192-000	9	B-9,10		CF1-0991-000	3	A-11,12
	CA1-4193-000	9	B-9,10		CF1-0992-000	3	A-11,12
					CF1-0995-000	2	A-9,10

INDEX OF PARTS NUMBERS

NEW	PART NO.	PAGE	ADDRESS	NEW	PART NO.	PAGE	ADDRESS
	CF1-0996-000	4	A-13,14		CS1-6540-000	3	A-11,12
	CF1-0997-000	10	B-11,12		CS1-7376-000	8	B-7,8
	CF1-1021-000	5	B-1,2		CS1-7378-000	1	A-7,8
	CF1-1022-000	4	A-13,14		CS1-7383-000	8	B-7,8
	CF1-1281-000	12	C-1,2		CS2-6109-000	4	A-13,14
	CG1-0173-000	12	C-1,2		CY1-1112-000	9	B-5,10
	CG1-0199-000	2	A-9,10		CY1-1113-000	12	C-1,2
	CG1-0200-000	11	B-13,14		CY1-1115-000	3	A-11,12
	CG1-0201-000	4	A-13,14		CY1-1116-000	6	B-3,4
	CG1-0207-000	7	B-5,6		CY1-1117-000	6	B-3,4
	CG1-0208-000	7	B-5,6		CY1-1118-000	4	A-13,14
	CG1-0209-000	7	B-5,6		CY1-1120-000	7	B-5,6
	CG9-2581-000	10	B-11,12		CY1-1200-000	1	A-7,8
	CH1-0378-000	4	A-13,14		CY4-9101-000	4	A-13,14
	CH1-0379-000	8	B-7,8		CY4-9202-000	6	B-3,4
	CH3-0015-000	15	C-6		CY4-9204-000	4	A-13,14
	CH4-0090-000	15	C-6		VR9-1087-000	16	C-7
	CH4-0105-000	15	C-6		VR9-1095-000	15	C-6
	CH9-0055-000	15	C-6		VR9-1099-000	15	C-6
	CH9-0072-000	16	C-7		VR9-1103-000	15	C-6
	CN1-5231-000	6	B-3,4		VR9-1109-000	15	C-6
	CN1-5233-000	4	A-13,14		VR9-1115-000	15	C-6
	CS1-0616-000	11	B-13,14		VR9-1116-000	16	C-7
	CS1-0617-000	11	B-13,14		VR9-1123-000	16	C-7
	CS1-0618-000	11	B-13,14		VR9-1321-000	16	C-7
	CS1-0619-000	11	B-13,14		VR9-1322-000	16	C-7
	CS1-0620-000	11	B-13,14		VR9-1323-000	16	C-7
	CS1-0621-000	11	B-13,14		VR9-1324-000	16	C-7
	CS1-0622-000	11	B-13,14		VR9-1413-000	16	C-7
	CS1-0623-000	9	B-9,10		VR9-1414-000	16	C-7
	CS1-0624-000	9	B-9,10		VR9-1415-000	16	C-7
	CS1-0625-000	9	B-9,10		VR9-1416-000	16	C-7
	CS1-0627-000	3	A-11,12		VR9-1417-000	16	C-7
	CS1-0628-000	3	A-11,12		VR9-1418-000	16	C-7
	CS1-4141-000	3	A-11,12		VR9-1419-000	16	C-7
	CS1-5626-000	8	B-7,8		VR9-1420-000	16	C-7
	CS1-5628-000	11	B-13,14		VR9-1421-000	16	C-7
	CS1-5629-000	11	B-13,14		VR9-1476-000	15	C-6
	CS1-5636-000	7	B-5,6		VR9-1753-000	15	C-6
	CS1-5637-000	7	B-5,6		VR9-1870-000	15	C-6
	CS1-5639-000	7	B-5,6		VR9-1871-000	15	C-6
	CS1-5653-000	7	B-5,6		VR9-1772-000	15	C-6
	CS1-5640-000	7	B-5,6		VR9-1873-000	15	C-6
	CS1-5642-000	7	B-5,6		VR9-1874-000	15	C-6
	CS1-5643-000	7	B-5,6		VR9-1875-000	15	C-6
	CS1-5644-000	7	B-5,6		VR9-1876-000	15	C-6
	CS1-5646-000	7	B-5,6		VR9-1877-000	15	C-6
	CS1-5649-000	7	B-5,6		VR9-1886-000	15	C-6
	CS1-5650-000	7	B-5,6		VR9-1887-000	15	C-6
	CS1-5651-000	7	B-5,6		VR9-1888-000	15	C-6
	CS1-5652-000	7	B-5,6		VR9-1889-000	15	C-6
	CS1-5653-000	7	B-5,6		VR9-1891-000	15	C-6
	CS1-5694-000	7	B-5,6		VR9-1892-000	15	C-6
	CS1-6500-000	12	C-1,2		VR9-1893-000	15	C-6
	CS1-6535-000	10	B-11,12		VR9-1896-000	15	C-6
	CS1-6538-000	11	B-13,14		VR9-2291-000	15	C-6
	CS1-6539-000	3	A-11,12		VR9-2292-000	16	C-7
					VR9-2293-000	16	C-7
					VR9-2367-000	16	C-7
					VR9-2368-000	16	C-7
					VR9-2369-000	16	C-7

INDEX OF PARTS NUMBERS

NEW	PART NO.	PAGE	ADDRESS	NEW	PART NO.	PAGE	ADDRESS
	WR9-2370-000	14	C-7		X99-0424-000	5	B-1,2
	WA2-0213-000	14	C-7		X99-0425-000	5	B-1,2
	WA2-0228-000	16	C-7		X99-0426-000	2	A-9,10
	XA1-1170-189	6	B-3,4		X99-0427-000	2	A-9,10
	XA1-1170-209	6	B-3,4		X99-0432-000	5	B-1,2
	XA1-1200-229	3	A-11,12		X99-0433-000	2	A-9,10
	XA1-1200-309	2	A-9,10		X99-0434-000	4	A-13,14
	XA1-3170-159	6	B-3,4		X99-0435-000	10	B-11,12
	XA1-3170-309	2	A-9,10		X99-0437-000	3	A-11,12
	XA1-3200-509	6	B-3,4		X99-0438-000	8	B-7,8
	XA1-6340-147	4	A-13,14		X99-0452-000	8	B-7,8
	XA1-6170-359	7	B-5,6		X99-0454-000	5	B-1,2
	XA1-7140-229	9	B-9,10		X99-0455-000	1	A-7,8
	XA1-7170-359	4	A-13,14		X99-0460-000	1	A-7,8
					X99-0481-000	3	A-11,12
	XA5-6170-459	10	B-11,12		Y11-3702-000	16	C-7
	XA5-6200-409	3	A-11,12		Y11-3703-000	16	C-7
		4	A-13,14		Y11-3901-000	16	C-7
		8	B-7,8		Y11-3902-000	16	C-7
		10	B-11,12		Y11-3903-000	16	C-7
	XA5-6200-459	5	B-1,2		Y11-3906-000	16	C-7
		8	B-7,8		Y11-3907-000	16	C-7
		10	B-11,12		Y11-3909-000	16	C-7
					Y11-3911-000	16	C-7
					Y11-3912-000	16	C-7
	XD1-1102-120	6	B-3,4		Y11-4501-000	16	C-7
	XD1-1102-121	6	B-3,4		Y11-4502-000	16	C-7
	XD1-1103-113	11	B-13,14		Y11-4503-000	16	C-7
					Y11-4506-000	16	C-7
	X02-1100-072	6	B-3,4		Y11-4507-000	16	C-7
	X02-1100-202	11	B-13,14		Y11-4509-000	16	C-7
	X02-1200-152	2	A-9,10		Y11-4511-000	16	C-7
	X08-1100-541	8	B-7,8		Y11-4512-000	16	C-7
					Y11-4513-000	16	C-7
					Y11-4514-000	16	C-7
	X71-9749-000	7	B-5,6				
	X71-9750-000	3	A-11,12				
		7	B-5,6				
	X91-1436-310	12	C-1,2				
	X91-1436-540	9	B-9,10				
	X91-1436-570	9	B-9,10				
	X91-1436-590	9	B-9,10				
	X91-1436-610	3	A-11,12				
	X91-1436-620	3	A-11,12				
	X91-1436-630	5	B-1,2				
	X91-1724-640	10	B-11,12				
	X91-1725-100	11	B-13,14				
	X91-1737-200	6	B-3,4				
	X91-1737-380	1	A-7,8				
	X91-1737-410	1	A-7,8				
	X91-2024-870	8	B-7,8				
	X91-2035-840	9	B-9,10				
		11	B-13,14				
	X98-0202-060	6	B-3,4				
	X99-0295-000	5	B-1,2				
		8	B-7,8				
	X99-0299-000	10	B-11,12				
	X99-0420-000	8	B-7,8				
		10	B-11,12				
	X99-0472-000	3	A-11,12				
	X99-0421-000	4	A-13,14				