

Canon®

T70

**MULTIPLE PROGRAM AE
DUAL METERING SYSTEM**

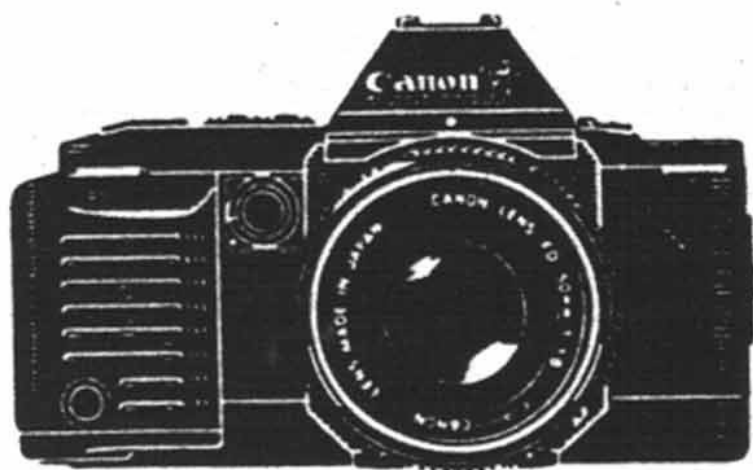

REPAIR GUIDE

Table of Contents

T-70

- 1. Repair Instructions
- 2. Parts Catalog

C O N T E N T S

	Page	Address
I. ASSEMBLY & DISASSEMBLY	1	A-5
I-1. Covers	1	A-5
I-2. Top Cover Parts	3	A-7
I-3. Main Flex Removal	5	A-9
I-4. LCD Unit	9	A-13
I-5. Front Panel, Pentaprism	11	B-1
I-6. Front Panel Parts	13	B-3
I-7. Shutter, Upper Winding Parts	19	B-9
I-8. Sprocket Removal	21	B-11
(AL Cover and Lower Winding Parts)		
I-9. Lower Winding Base	23	B-13
II. ADJUSTMENTS		
Table of Contents.....	26	C-2

COLOR CODE

To save space on drawings, it has been necessary to use a color code. The code is:

Black	BL	Blue	BU	Gold	GL
Brown	BR	Violet	V	Tan	T
Red	R	Purple	PR	Pink	PK
Orange	O	Gray	GY	Sky Blue	SB
Yellow	Y	White	W	Yellowish Green	YG
Green	GN	Silver	S		

I. ASSEMBLY & DISASSEMBLY

I-1. Covers

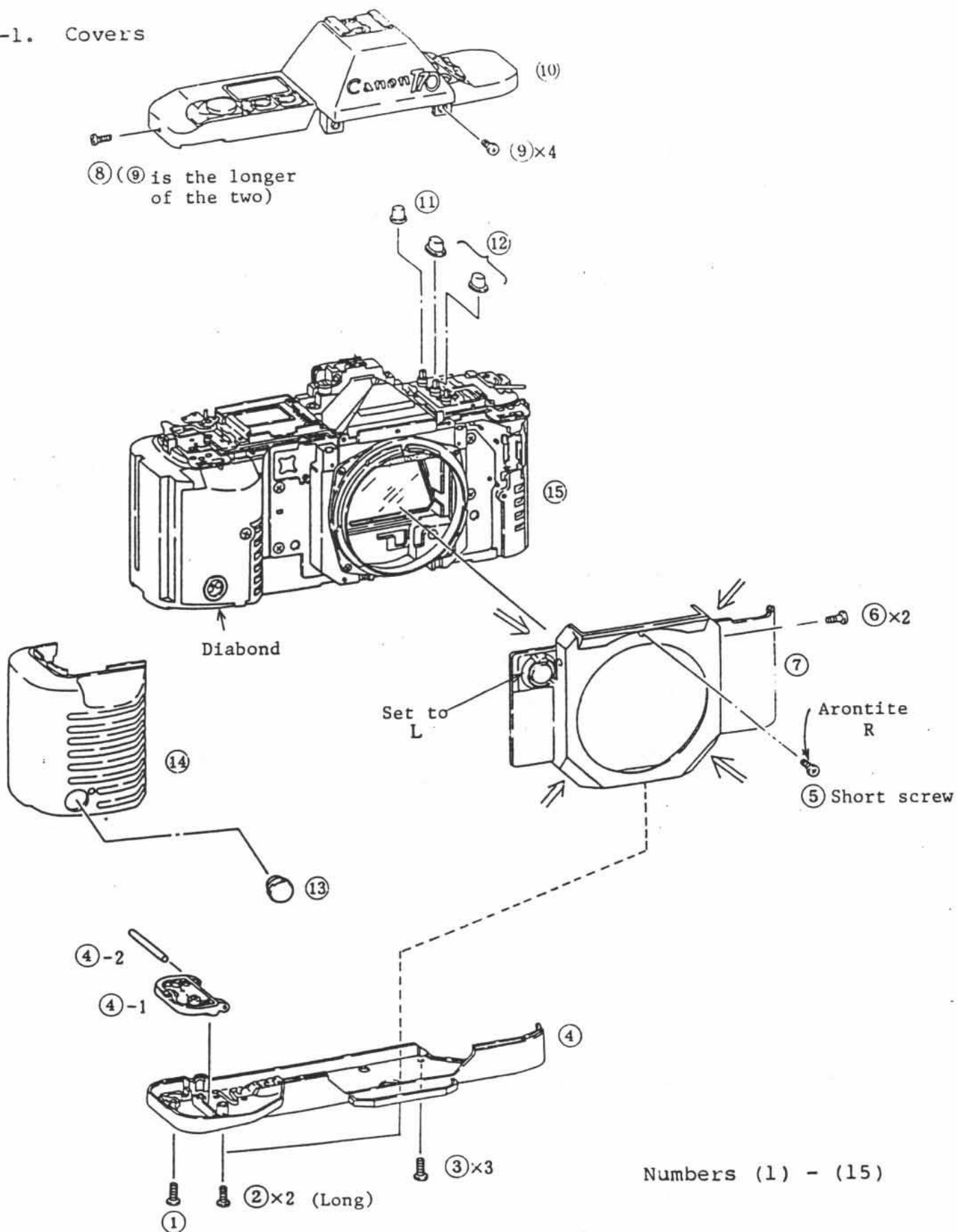

I. ASSEMBLY & DISASSEMBLY

I-1. Covers

Disassembly Notes

1. Bottom Cover (4): Push the film rewind button in the marked direction before removing the bottom plate. This is necessary to prevent deforming of the spring which would cause the button to not operate smoothly.
2. Front Cover (7): Set the shutter speed shift lock lever to "L" to prevent bending the switch contacts. Loosen the two screws in the right end cover (4) . Pinch the front cover at the four corners as shown and lift off.
3. Top Cover (10): To remove the top cover completely, unsolder the seven leads shown below.

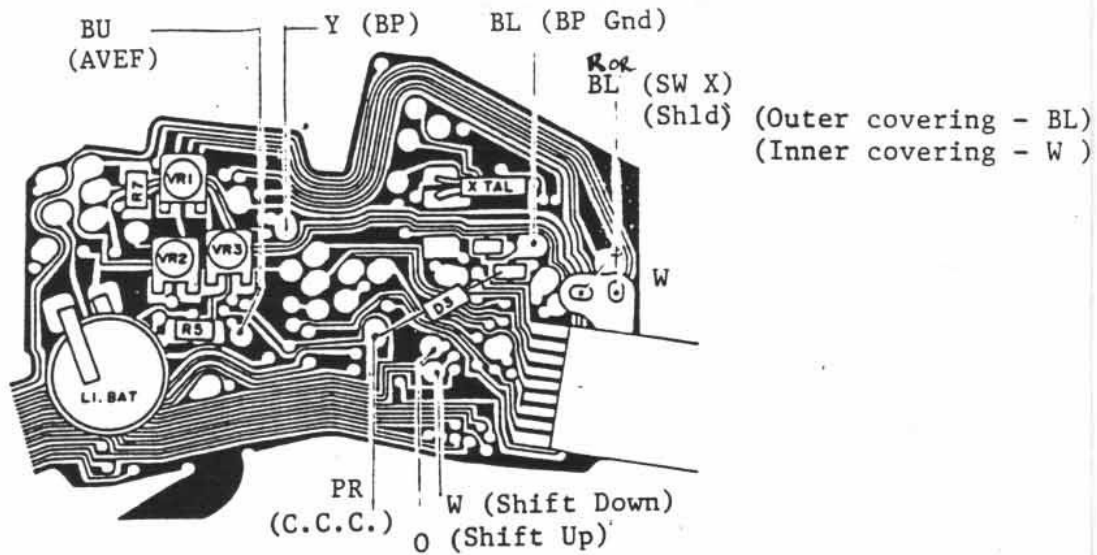

Assembly Notes

1. After resoldering shielded leads, be sure to recover with insulating tape.
2. Don't pinch wires when reinstalling the covers.
3. Screw (5) is shorter than the other cover screws. If a longer screw is used here it will scratch the pentaprism.
4. When reinstalling the bottom cover, push the film rewind button as explained above.

I. ASSEMBLY & DISASSEMBLY

I-2. Top Cover Parts

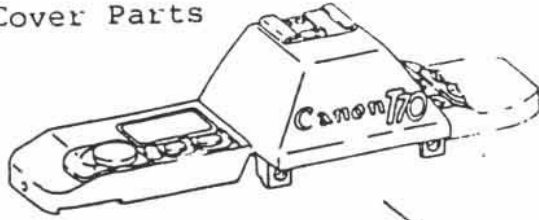

①-2

A	A
	5.3mm
	5.5mm
	6.7mm

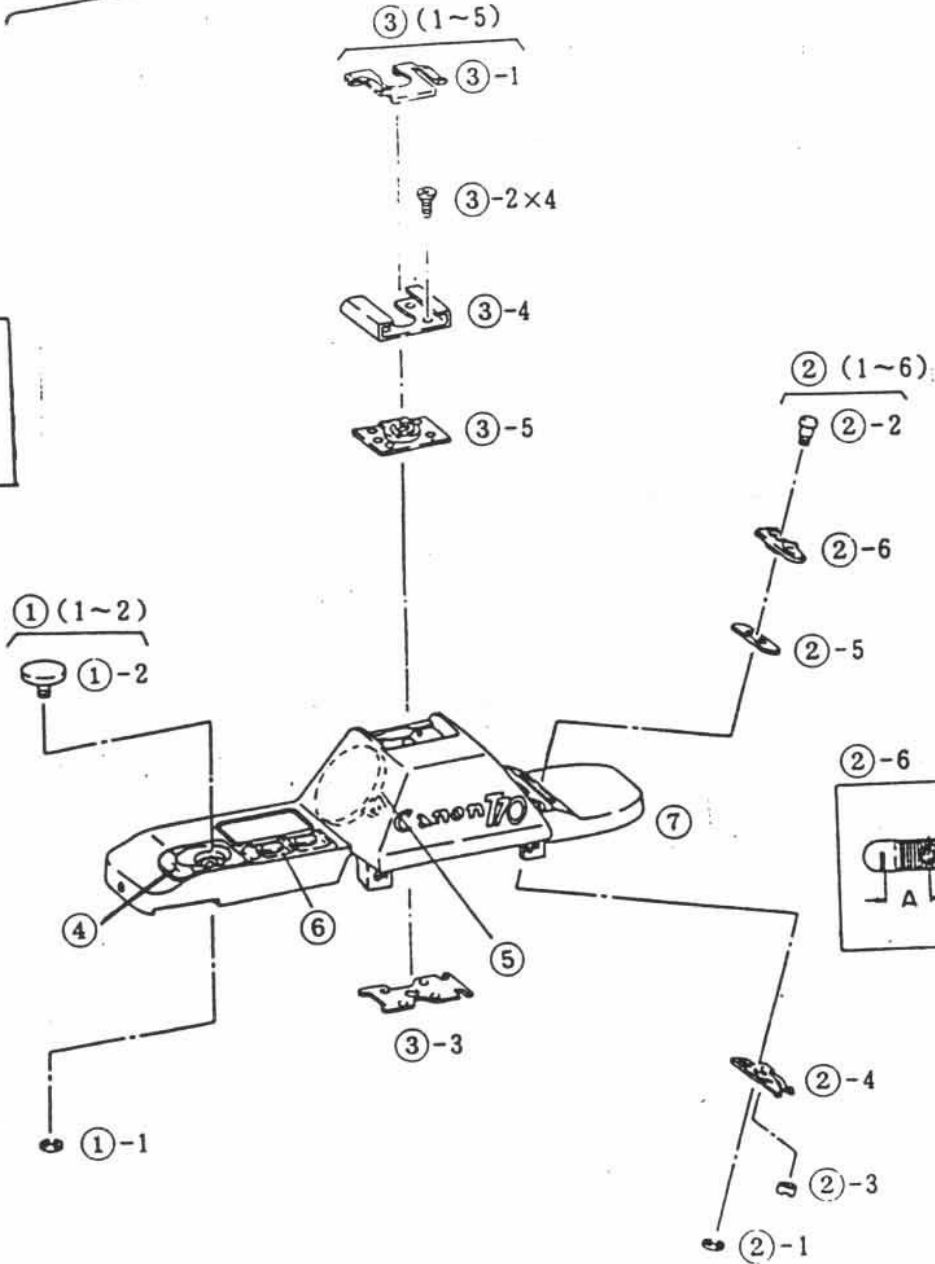

②-6

A	A
	8.15mm
	8.30mm
	8.40mm

Numbers (1) - (16)

I. ASSEMBLY & DISASSEMBLY

I-1. Top Cover Parts

Disassembly Notes

1. Shutter Button Seat (4), Beeper (5), and Swift Switch (6) are all bonded to the top cover with diabond.

Assembly Notes

1. The maximum height of the shutter button above its seat should be $0.3 \pm 0.3\text{mm}$ when the button is all the way up.
2. Insure that the index of the selector lever (2)-6 aligns with the different selected indices on the top cover.

I. ASSEMBLY & DISASSEMBLY

I-3. Main Flex Removal

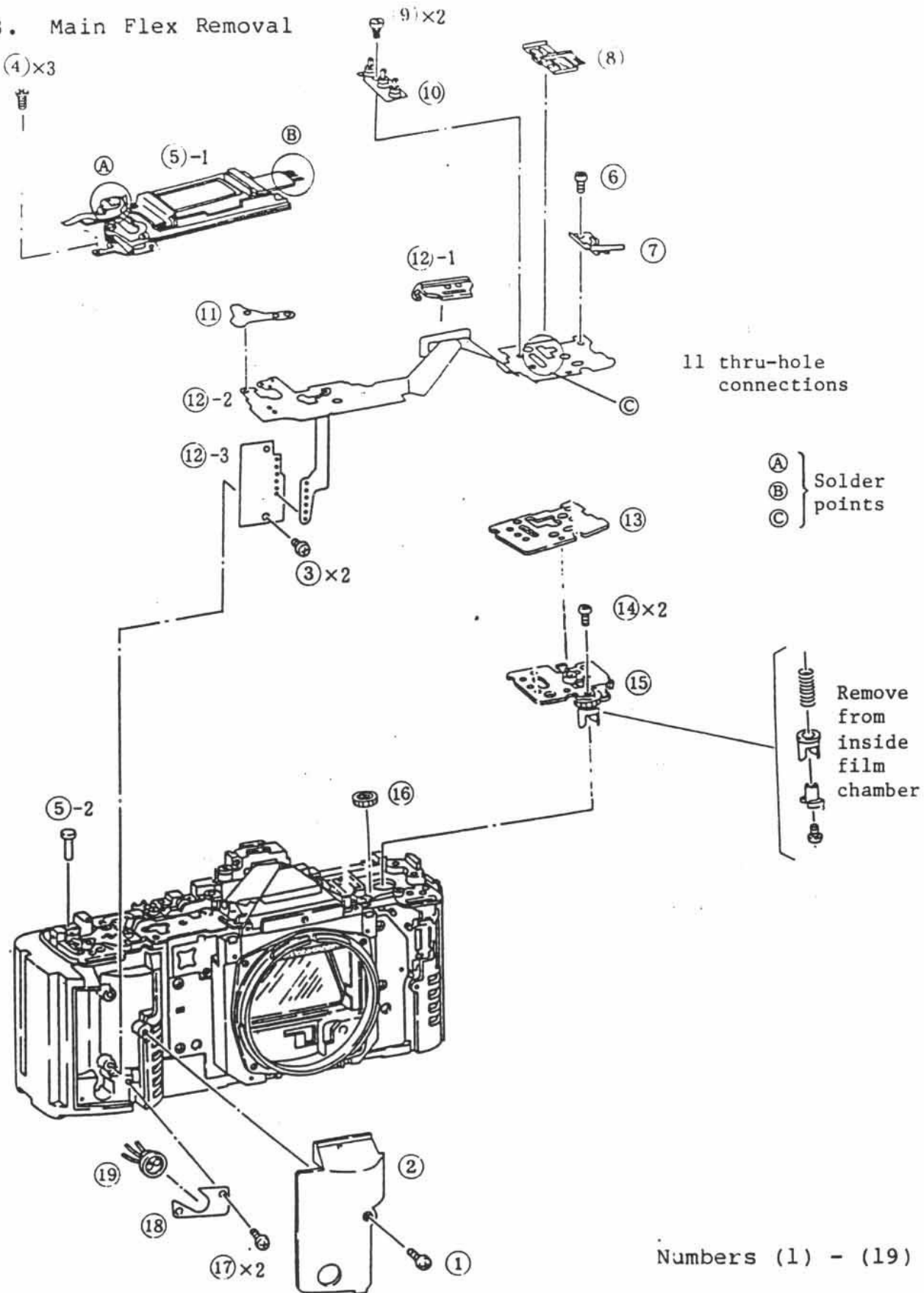

I. ASSEMBLY & DISASSEMBLY

I-3. Main Flex Removal

Disassembly Notes

1. To remove the LCD panel (5), the jumper wires (B) and main flex leads (A) have to be unsoldered and three screws (4) removed.
Caution: 1. One of the thru-hole pins at (A) has an enlarged head. Use solder wick and be careful not to tear the flex when removing the flex.
2. Don't use force when unsoldering the (B) section.

2. Main Flex Removal

- 2.1. SPC stopper (12)-1 is bonded to the SPC. Remove it with the flex.
- 2.2. Remove solder from the 11 thru-hole pins in (12)-2 with solder wick. See page 8 for positions.
- 2.3. Remove the 12 lead wires from the main flex (12). See page 7 for positions.
- 2.4. Unsolder the 5 solder points on the shutter flex.
- 2.5. Unsolder the LED jumper leads (C).

Adjustment Notes

1. Don't exert pressure on the flex after the thru-hole pins are soldered. This could break the underside pattern.
2. Don't use excess solder. This could cause shorts between the LCD panel and ground.
3. When installing the SPC stopper, engage the elongated hole first.
4. When installing the LCD (5)-1 and soldering at (A), don't release them until the solder is thoroughly set, or it may splatter all over.
5. Install the remote jack (19) and its holder (18) as shown.

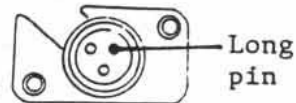

6. Back Cover Switch (7)
 - 6.1. With the back cover open, hold the opening hook down and push the lock lever in the marked direction so they latch.
 - 6.2. Push the back cover switch (7) in the direction shown and fix it in place.

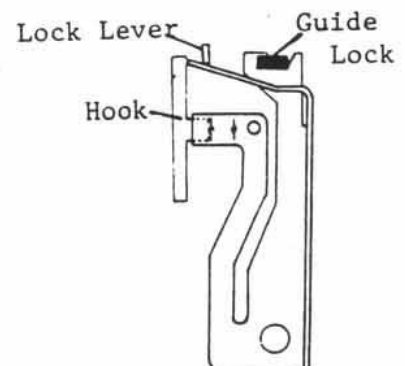

I. ASSEMBLY & DISASSEMBLY

I-3. Main Flex Removal

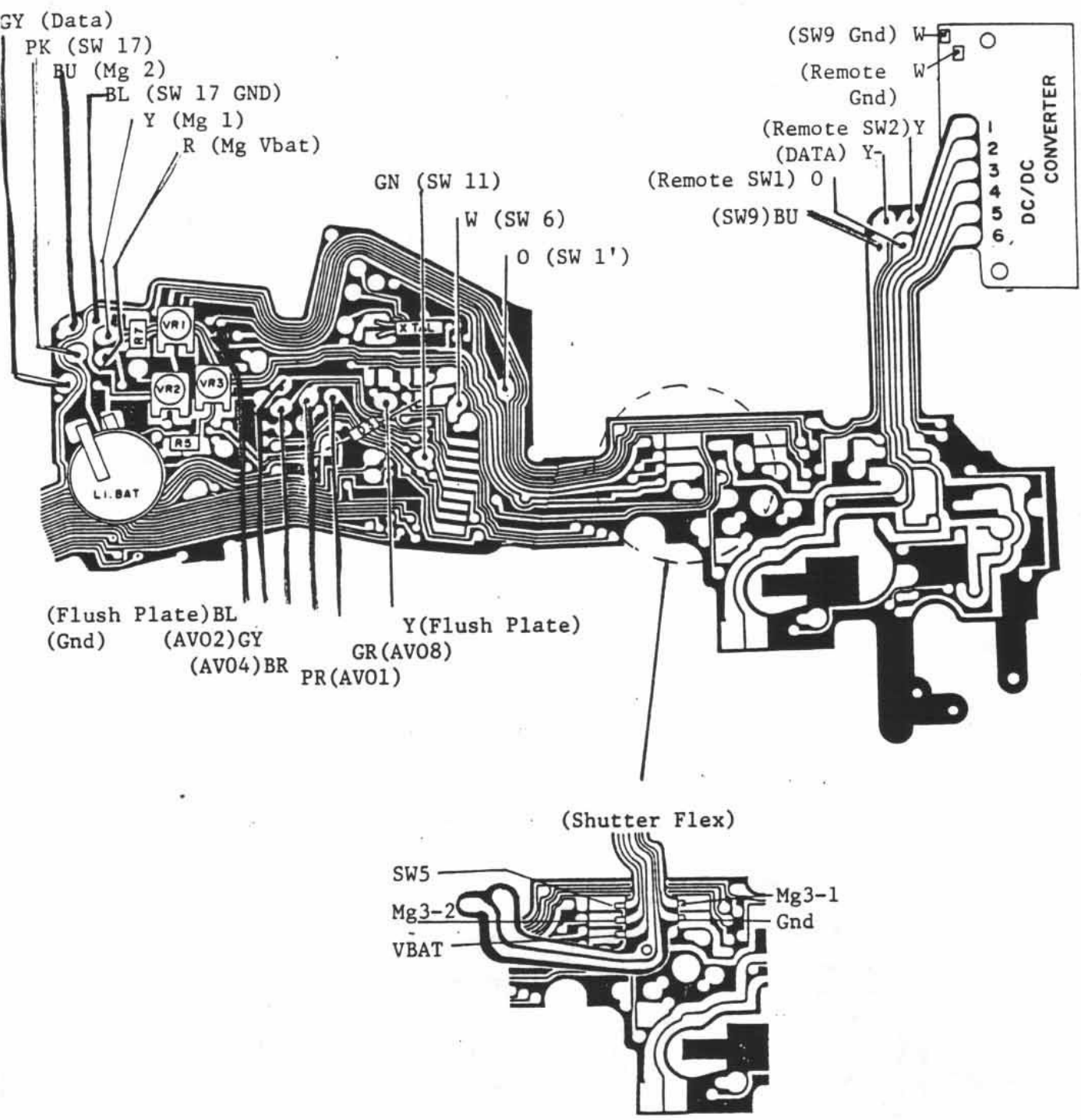

I. ASSEMBLY & DISASSEMBLY

I-3. Main Flex Removal

Thru-hole Connections:

- A: SW4-2
 - B: SW4-M (Enlarged head)
 - C: SW4-1
 - D: SW10 GND
 - E: SW18 GND
 - F: SW18
 - G: Data (+)
 - H: SW10
 - I: Motor (-)
 - J: VBAT (+) (Enlarged Head)
 - K: VBAT (-) (Enlarged Head)
- To LCD Board:
- 1: SW3 (Enlarged Head)
 - 2: SW1
 - 3: GND
 - 4: SW2

↑ : Enlarged Head

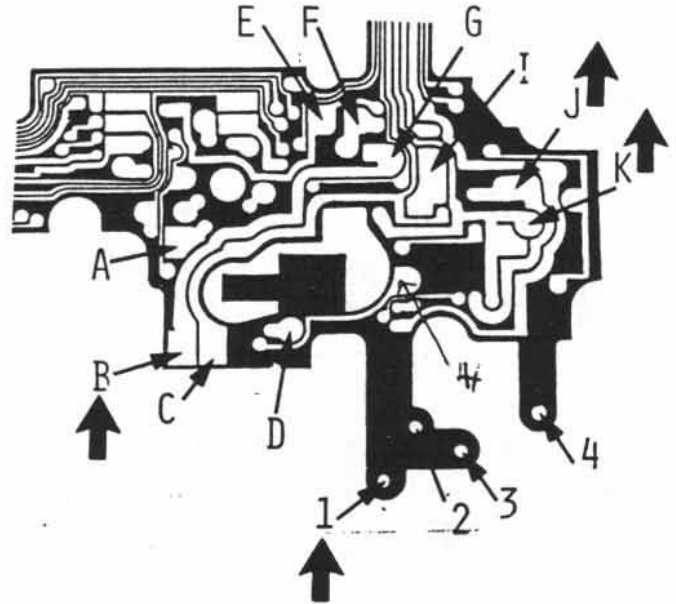

Apply insulating tape over the area shown.

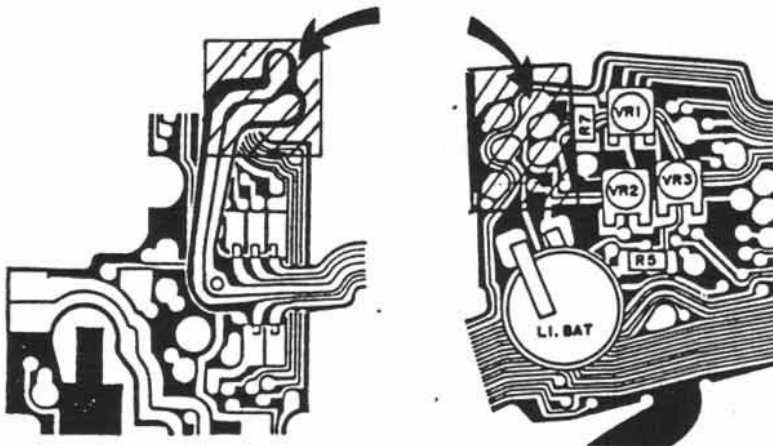

I. ASSEMBLY & DISASSEMBLY

I-4. LCD Unit

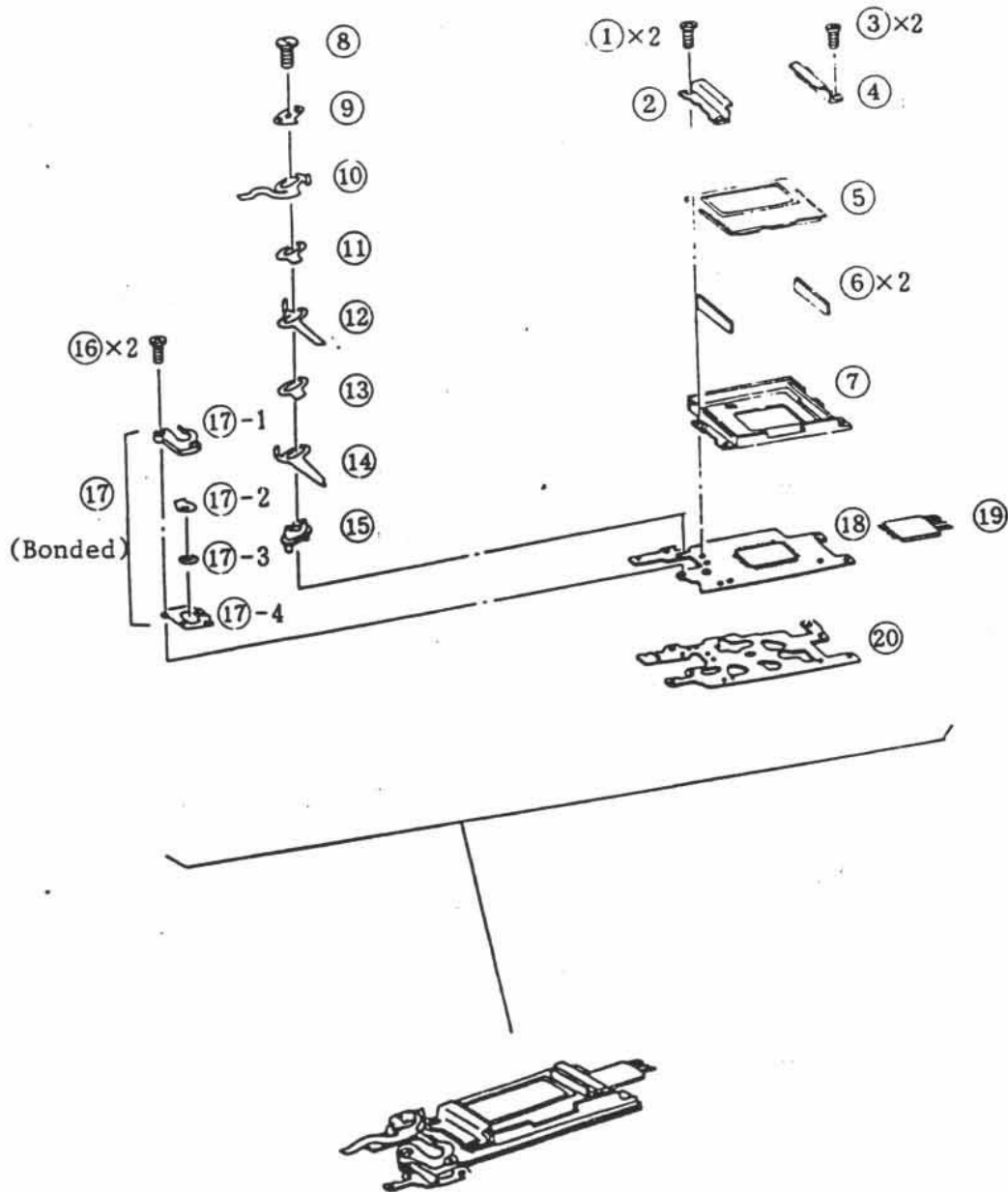

Numbers: (1 - 17)

81

I. ASSEMBLY & DISASSEMBLY

14

I-4. LCD Unit

Disassembly Notes

1. Don't scratch the surface of the LCD (5). To clean it, wipe lightly with Fronsolve AE.
 2. Switch holders (17)-1 and (17)-4 are welded together and cannot be separated. Take care not to lose (17)-2 and 3 when screws (16) are removed.
 3. The ends of jumper lead (19) break easily. Take care not to bend them too much.
-

Adjustment Notes

1. Be sure the elastic connectors (6) are clean before installing them.
2. When installing (17)-2 and 3, make sure the convex side of 17-3 is next to (17)-2.
3. After assembling and installing the main switch parts (8) through (17), check that it makes the proper muted clicking sound (peko-peko in Japanese).

I-5. ASSEMBLY & DISASSEMBLY

I-5. Front Panel, Pentaprism

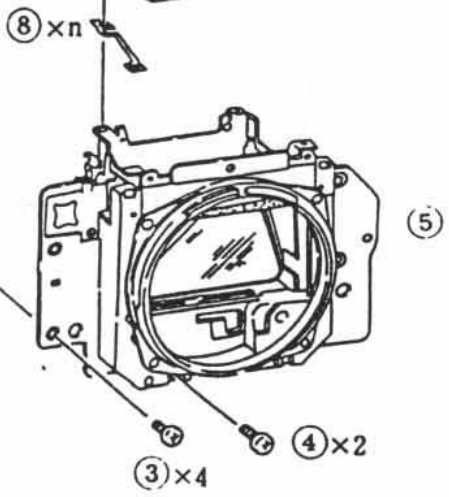
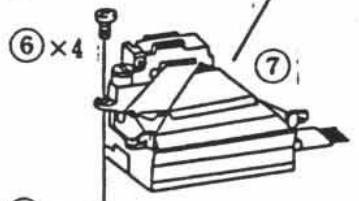
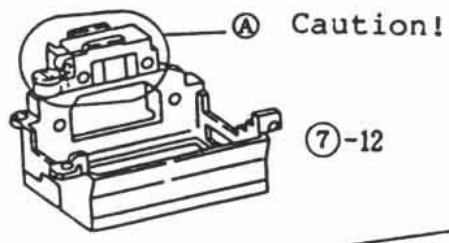
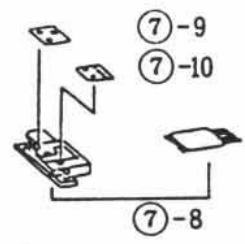
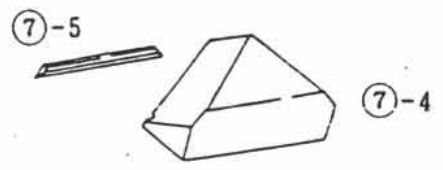
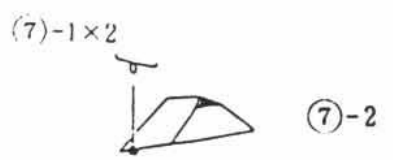
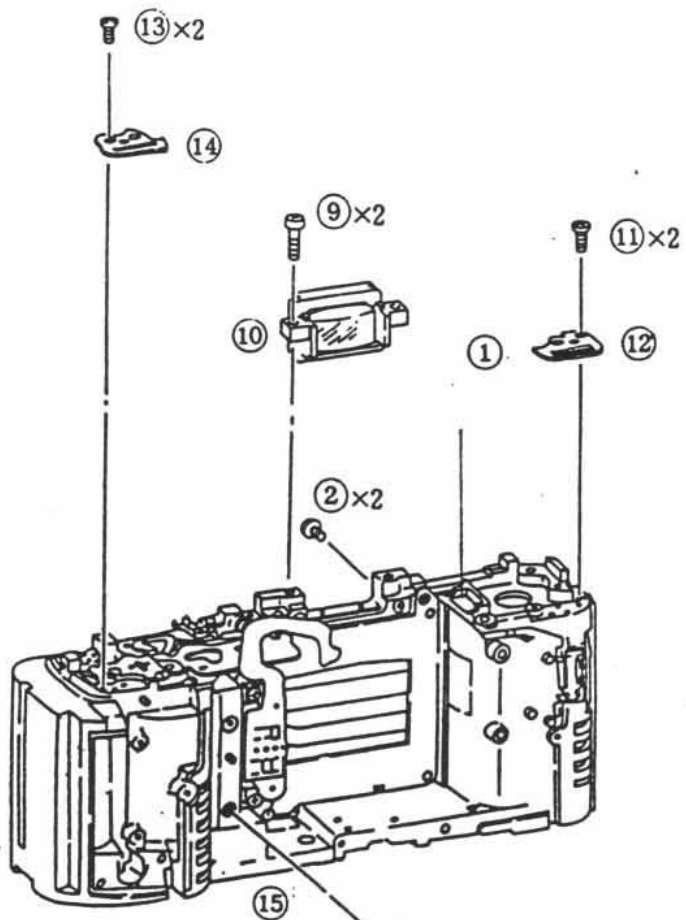

I-5. Front Panel, Pentaprism

Disassembly Notes

1. Remove Holder (1) (squeeze in, lift out) , and straighten the LED jumpers to prevent catching when the front panel is removed.
2. If SPC Holder (A) is removed, an extensive alignment procedure is required. Remove it only if necessary.
3. Rubber dust shields are used in the area of the pentaprism (7)-4 and the LED (7)-8. Remove them before removing the main part.

Adjustment Notes

1. Install the front panel (5) into the body (15) with the shutter open and the mirror up.
2. Reinstall all rubber dust seals in the proper position.
3. If SPC Holder (A) was removed from the front panel, perform the SPC positioning adjustment.
4. Install the focusing screen (7)-11 with the two notches up and toward the LED.

Lubrication and Spring Anchor Position

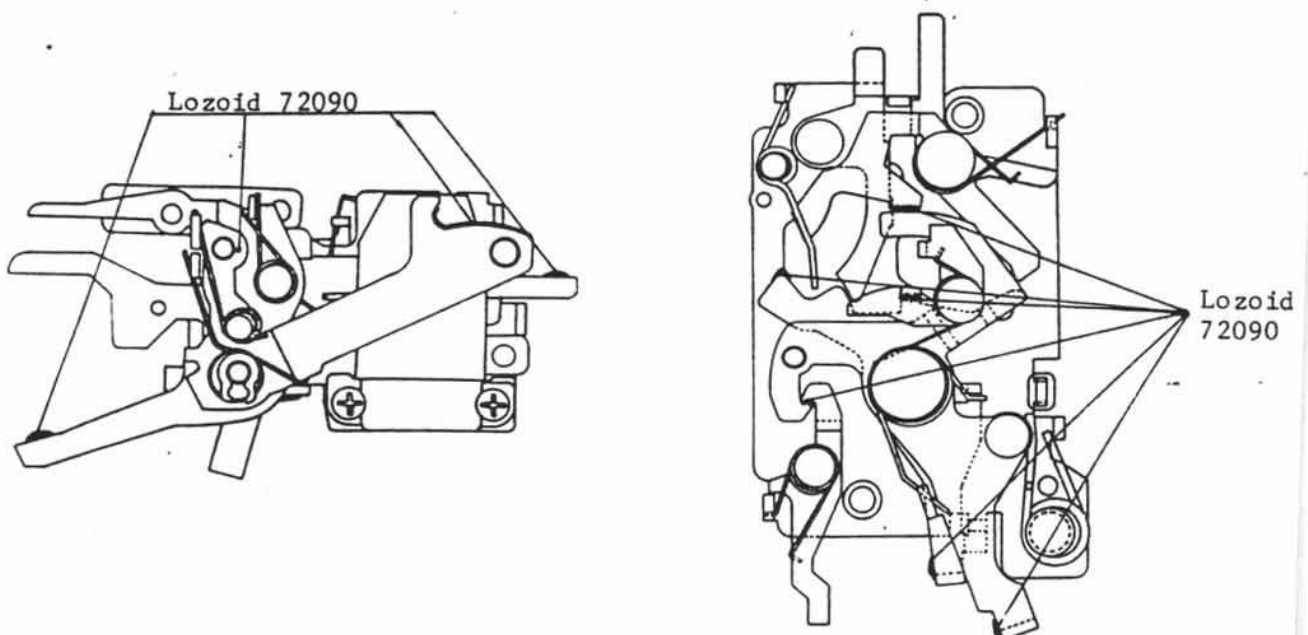

I. ASSEMBLY & DISASSEMBLY

I-6. Front Panel Parts

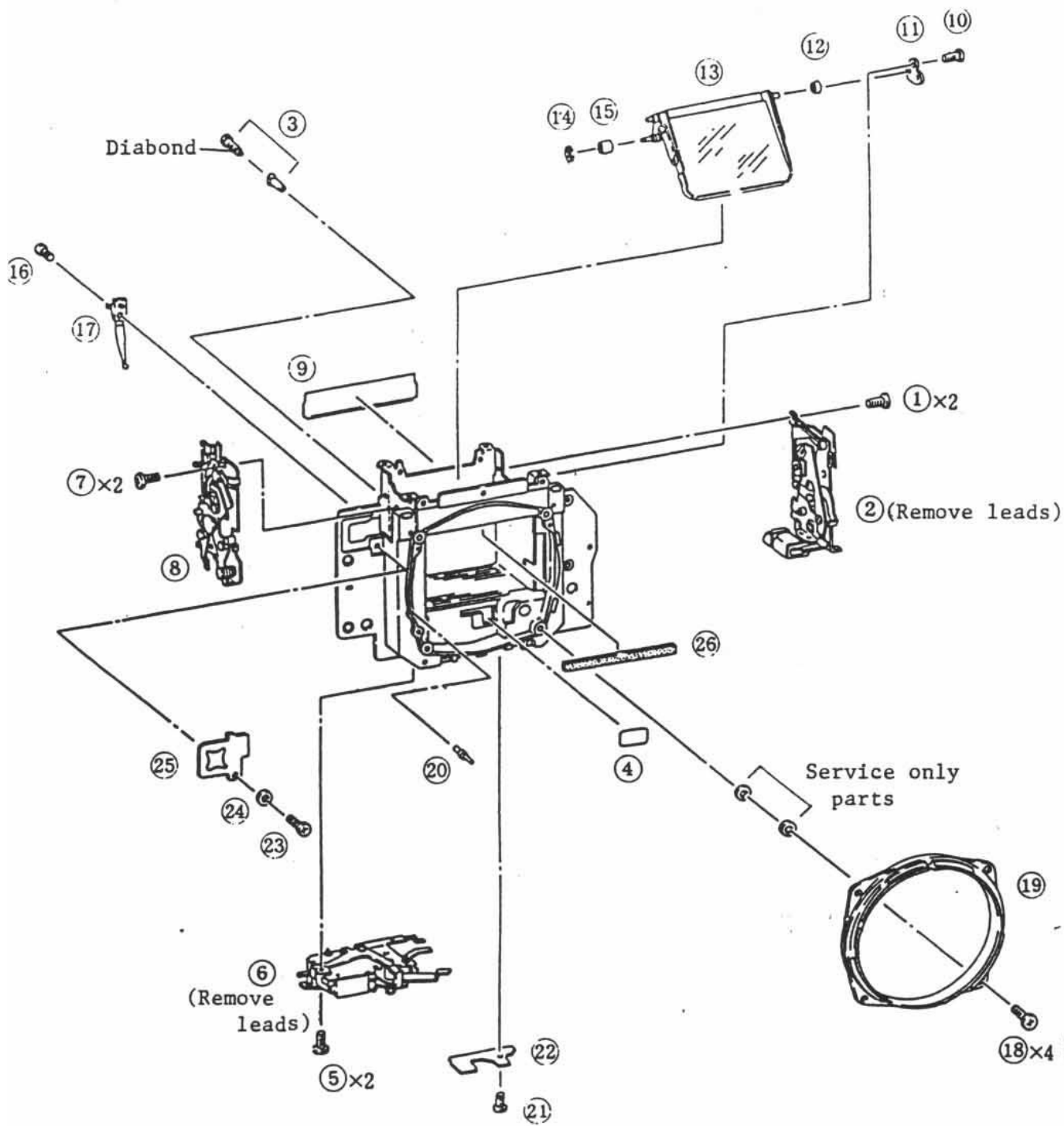

25 Wiring



22 Wiring

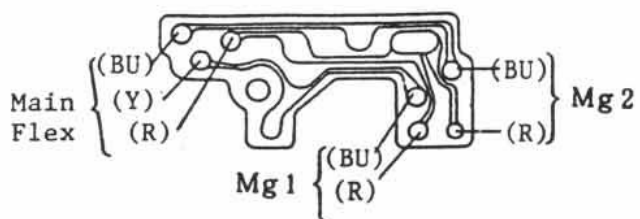

I. ASSEMBLY & DISASSEMBLY

I-6. Front Panel Parts

1. AE Unit Adjustment

2. AE Eccentric Gap Adjustment

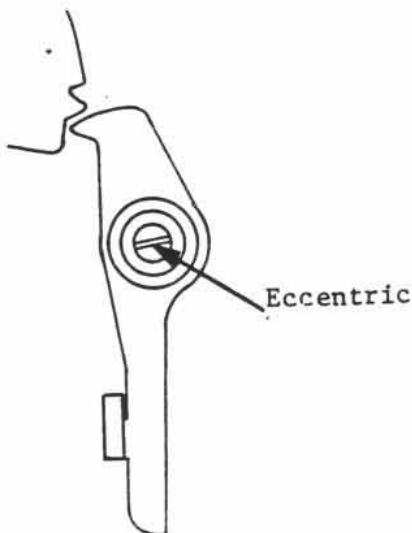
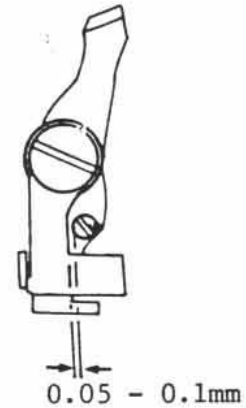
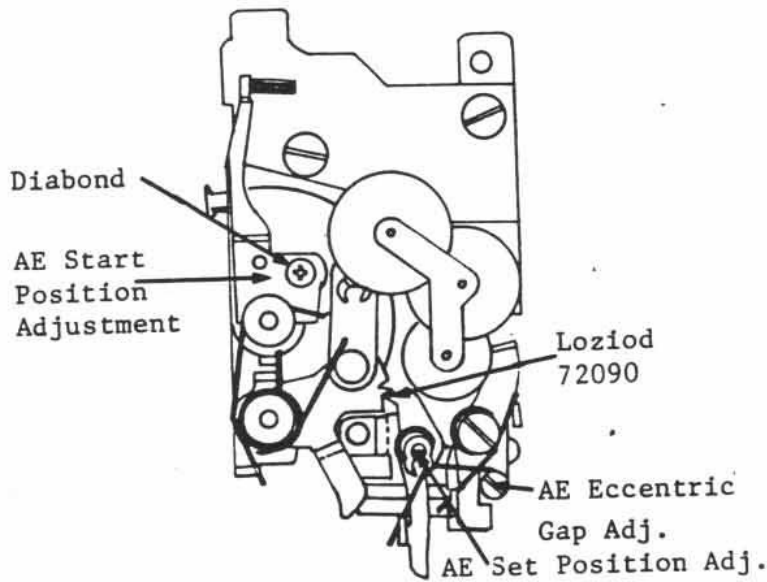

3. Set Position Adjustment

Attach a tool standard lens and read the AE set position; adjust by turning the eccentric.
 (Norm: $0.4 \pm 0.2F$).

- o One or two steps of overcharge is sufficient for the front panel by itself.
- o If a tool standard lens is not available, install an ordinary standard lens (to place a load on the aperture signal charge lever) and adjust to obtain seven turns plus six teeth, ± 1 tooth.

I. ASSEMBLY & DISASSEMBLY

I-6. Front Panel Parts

4. AE Start Position Adjustment

- 4.1. Attach a standard lens.
- 4.2. With the front panel set for automatic exposure, loosen the screw indicated in Figure 1 on page 14 and adjust the AE brush so that its tip is positioned between A and B. After completing the adjustment, paint the head of the screw with G103.
- 4.3. Connect the + probe of a multimeter to A' and the - probe to the metal part of the AE unit; adjustment is satisfactory if there is no conductivity between the two points. Also confirm that there is no conductivity with the + probe of the multimeter connected to point B'.

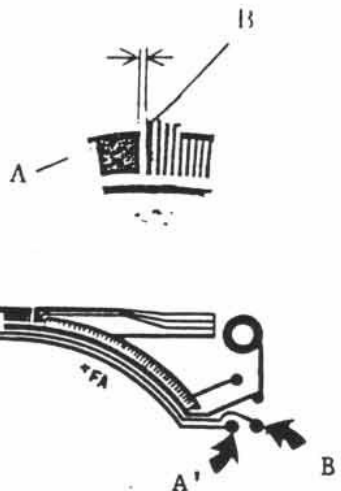

5. AE Precision Adjustment

- 5.1. AE precision can be adjusted by cutting the pattern as indicated in Figure xx. (However, adjustment is only possible in the direction indicated.)

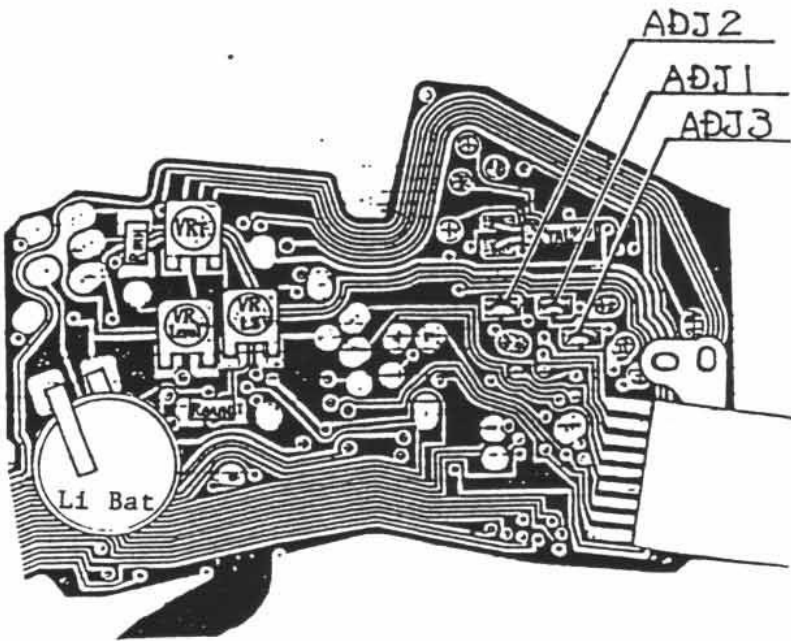

AE ADJ

AE. ADJ			Shift (F)
ADJ1	ADJ2	ADJ3	
OFF	OFF	OFF	0
ON	OFF	OFF	-1/8
OFF	ON	OFF	-2/8
ON	ON	OFF	-3/8
OFF	OFF	ON	+1/8
ON	OFF	ON	+2/8
OFF	ON	ON	+3/8
ON	ON	ON	+4/8

I. ASSEMBLY & DISASSEMBLY

I-6. Front Panel Parts

6. Mirror Installation Adjustment

See page 13 for procedures for installing the mirror.

6.1. Adjust thrust play along the mirror axis by replacing collar (12).

Standard: 0.05 - 0.3 mm.

Drive pin collar adjustment

6.2. Adjust spacing between the mirror and the shock absorbing cushion by replacing collar (15).

Standard: 0 - 1.0mm



6.3. Mirror 45° adjustment

Turn the 45° adjustment nut inside the mirror box with a hex wrench. (for large adjustment, move adjusting plate (11) (pg 13) slightly).

Standard:

Horizontal - Within 8'

Vertical - Within 3'

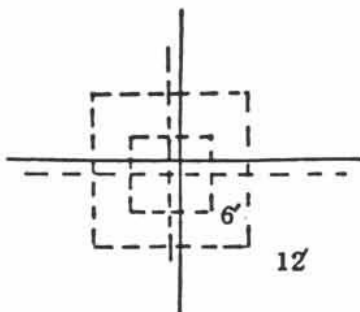

Note: Since the accuracy of horizontal positioning is determined by component precision, replace the mirror box on units which do not meet the standards.

I. ASSEMBLY & DISASSEMBLY

I-6. Front Panel Parts

7. A-M Switching Position Adjustment

Standards:

0.2 - 0.7 mm from the mount surface

Contact resistance - 1 ohm or less

Adjust the switching position by bending the contacts; test contact resistance by connecting the + probe of a multimeter to the lead coming from SW11 and the - probe to the metal part of the front plate. Switching should occur when the aperture ring of a standard lens mounted on the front plate is turned to the A mark.

8. Mgl Minimum Holding Voltage

Standard: 1 V or less

Inspection Procedure

1. With the front panel unit set and a standard lens mounted, connect the + side of a regulated power source to the + lead of Mgl and the - side to the - lead.
2. Apply 3 V from the regulated power source.
3. Start the AE mechanism.
4. Reduce the voltage level from the regulated power source and read the voltage at which Mgl is released.

I. ASSEMBLY & DISASSEMBLY

I-6. Front Panel Parts

9. AVO Adjustment

- 9.1. Connect the + probe of a multimeter to the green lead (AV08) from the AE unit and ground the - probe to the metal part of the front panel.
- 9.2. Set a depth gauge to 7.025 mm and check whether the AVO height is correct by confirming that switching between the f/2.5 and f/2.8 levels occurs within ± 0.03 mm of this height.
- 9.3. AVO is adjusted by means of a screw inside the maximum aperture compensation pin. (The screw is locked with G103; dissolve it with ketone.) After making the adjustment, paint the screw with G103.

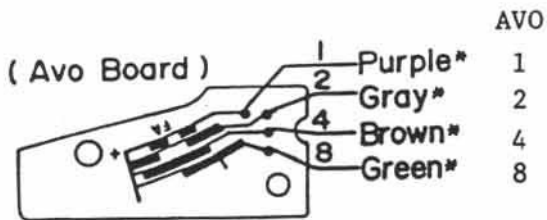

MAX F NO.	5.6	4.5	4.0	3.5	2.8	2.5	2.0	1.8	1.4	1.2
Pin Height ± 0.05 (mm)	5.70	6.00	6.30	6.57	6.90	7.15	7.46	7.72	8.10	8.38
Avo 8	1	1	1	1	1	0	0	0	0	0
Avo 4	0	1	1	1	1	1	1	1	1	0
Avo 2	1	1	1	0	0	0	0	1	1	1
Avo 1	0	0	1	1	0	0	1	1	0	0
Changeover	5.85	6.15	6.435	6.74	7.025	7.305	7.59	7.91	8.24	

I. ASSEMBLY & DISASSEMBLY

I-7. Shutter, Upper Winding Parts

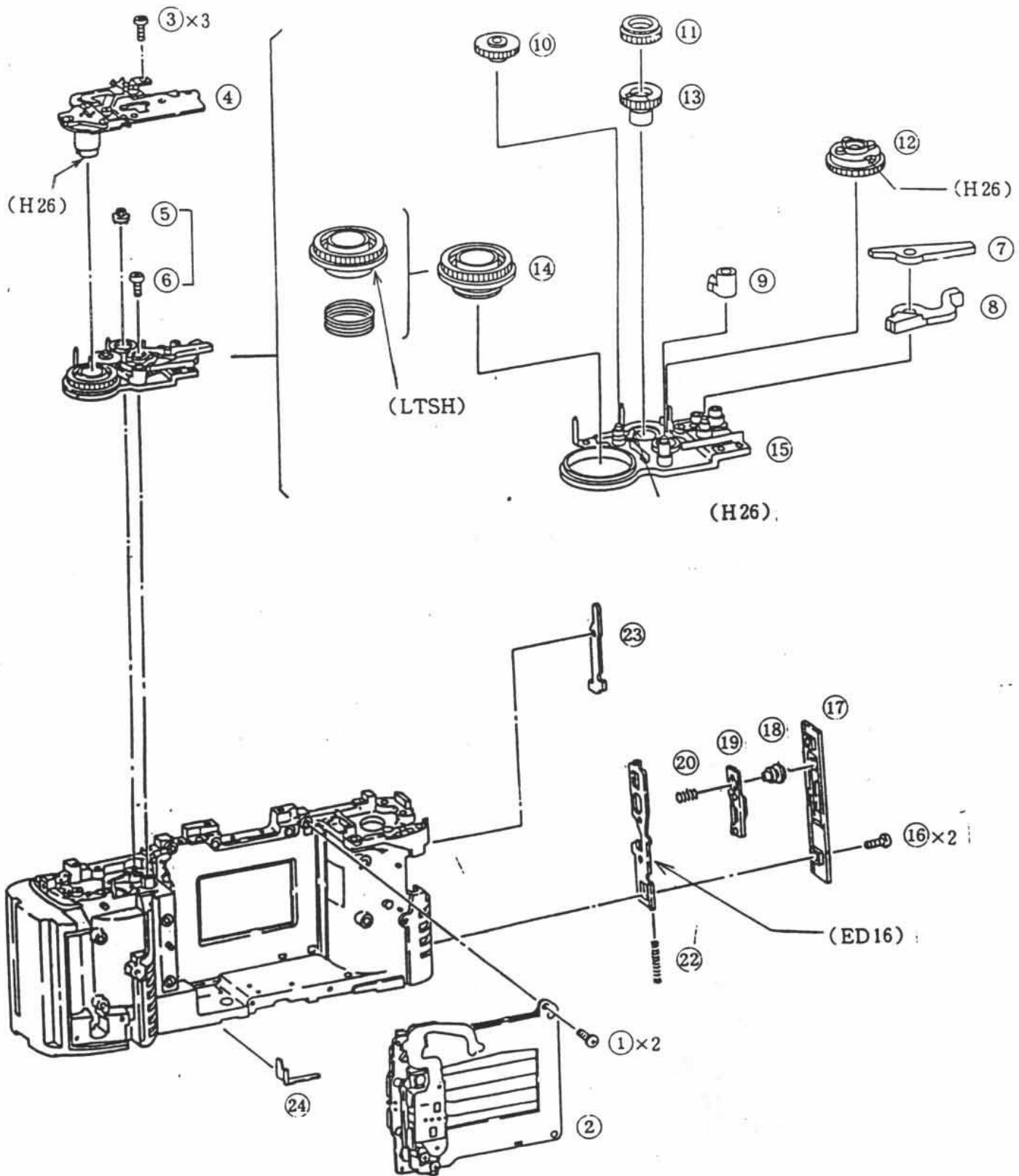

I. ASSEMBLY & DISASSEMBLY

I-7. Shutter, Upper Winding Parts

Disassembly Notes

1. Shutter Unit (2) Removal
 1. (3) through (24) need not be removed to remove the shutter unit.
 2. Don't bend the switch contacts on (4).
 3. Remove the shutter with it open.
2. Winding Baseplate Removal

Hold gear (12) with a compass while removing (5) and (6). (If it is not held, gears may be chipped).

Adjustment Notes

1. Shutter Unit Installation
 1. Before installing the shutter, check it according to the repair guide (located on the T50 Repair Guide microfiche).
 2. After installing the shutter, be sure to push the 1st curtain armature so the shutter is in the open position.
 3. Install light shield (24) as shown. It should not ride over the lip on the body.

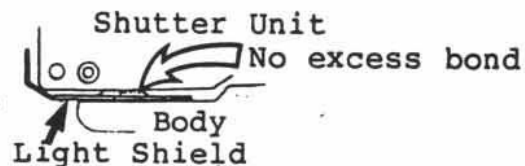
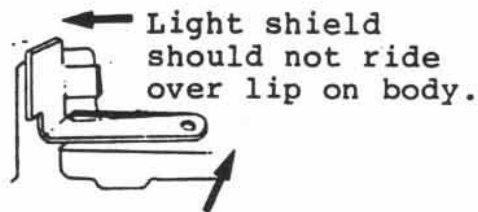

2. Winding Baseplate Installation
 1. Don't bend any of the contacts.
 2. Perforation Adjustment

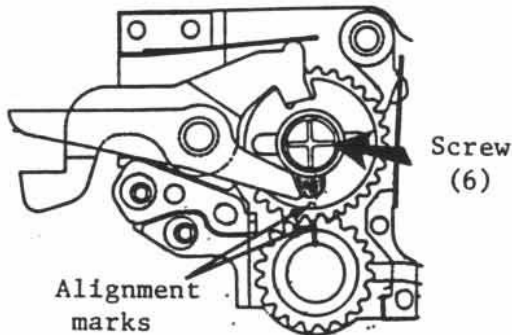

The drawing shows the position where the perforations should be aligned. The alignment marks align once for each three sprocket rotations. To wind, disengage the winding stopper and wind slowly with a screwdriver at screw (6). (Rough, fast winding may chip gears in the lower geartrain).

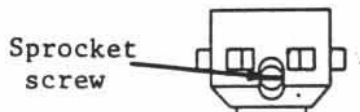

I. ASSEMBLY & DISASSEMBLY

I-8. Sprocket Removal
(AL Cover and Lower Winding Parts)

Lube 3 points

H26



Upper

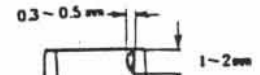

9 Detail



Lower

Lube
1/3 Cir

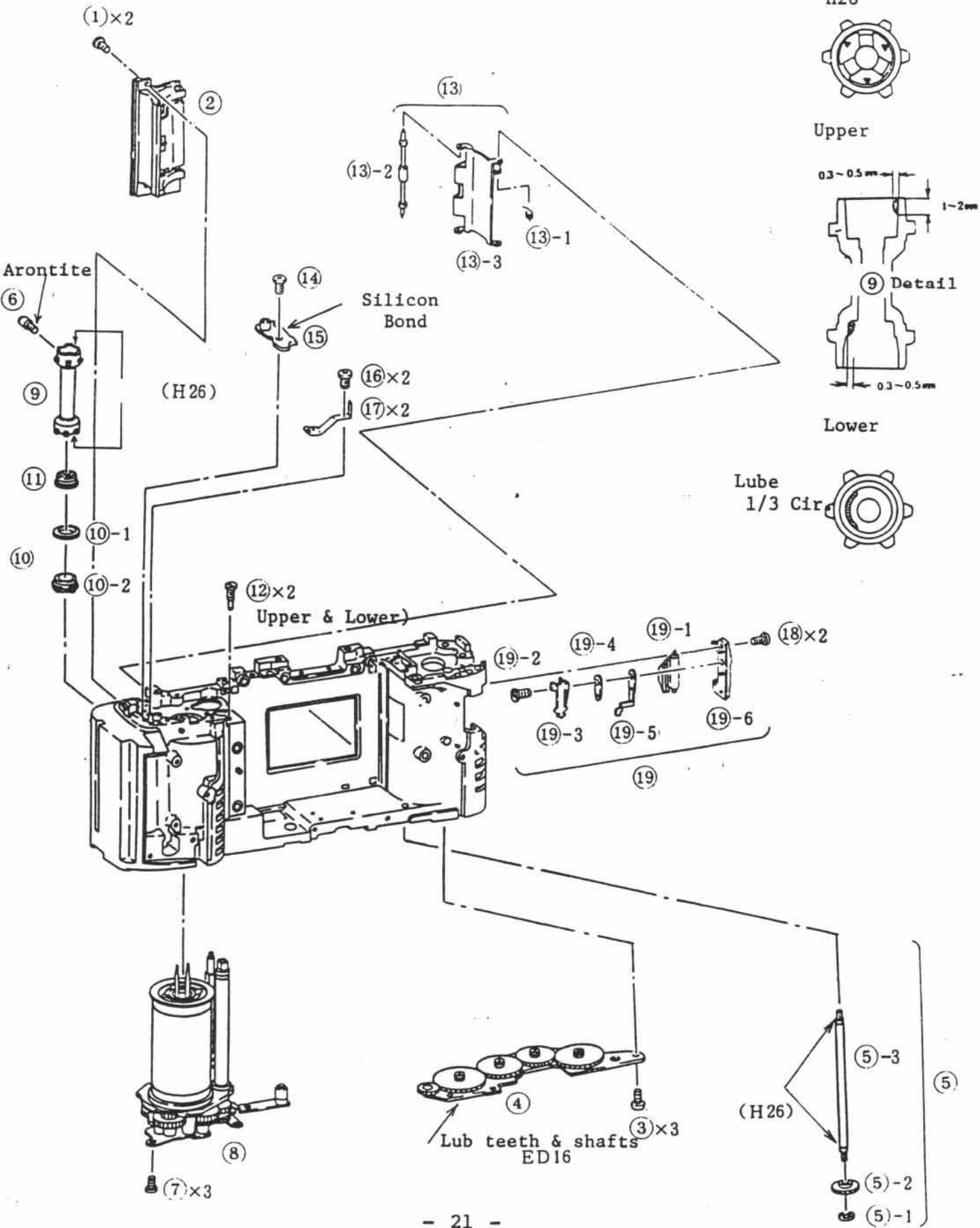

I. ASSEMBLY & DISASSEMBLY

I-8. Sprocket Removal (AL Cover and Lower Winding Parts)

Disassembly Notes

1. Remove the sprocket clutch screw before removing the upper winding baseplate.
2. Since the lower winding baseplate is only lightly welded, take care when removing it.

Adjustment Notes

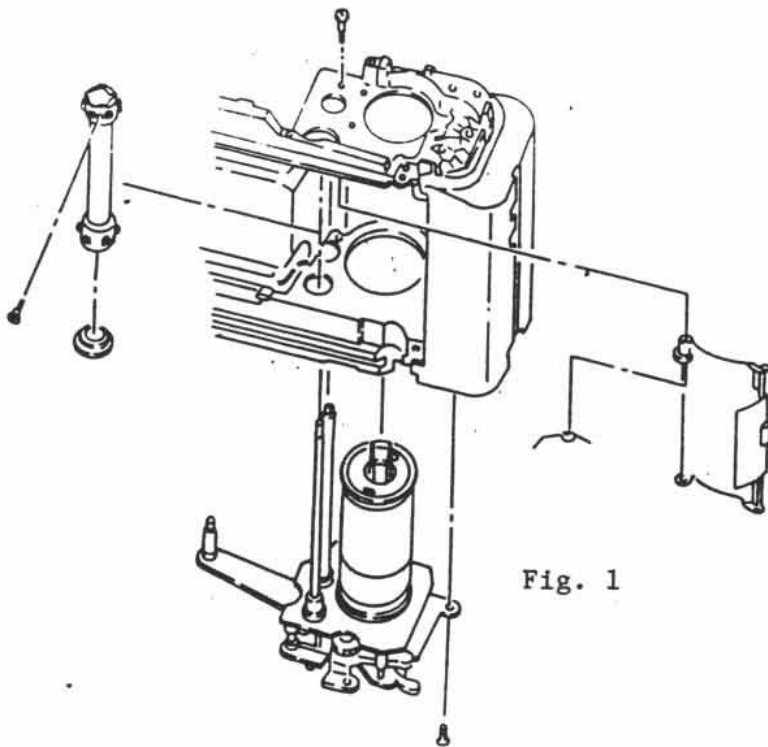

Fig. 1

1. There are flats on both sides of the sprocket shaft wher the sprocket shoe fits. Put Arontite on the tip of the screw.
2. Install the AL cover as shown in the drawing.
3. The AL cover operating spring should exert a pull of 60 to 90 gcm when the cover separares from the spool cover. The angle should be 115°.
4. Ensure that the end of the spring is fully inserted in the groove in the bdy.
5. Hold AL cover (13) out of the way while removing the lower winding baseplate (w/motor).
6. Batter Leak Protection Be sure to install silicon rubber in the roof of bat-tery chamber (15) to prevent battery leakage from corroding the inside of the camera.



Fig. 2

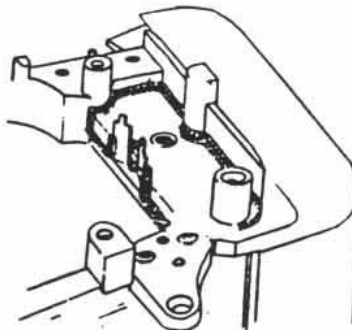
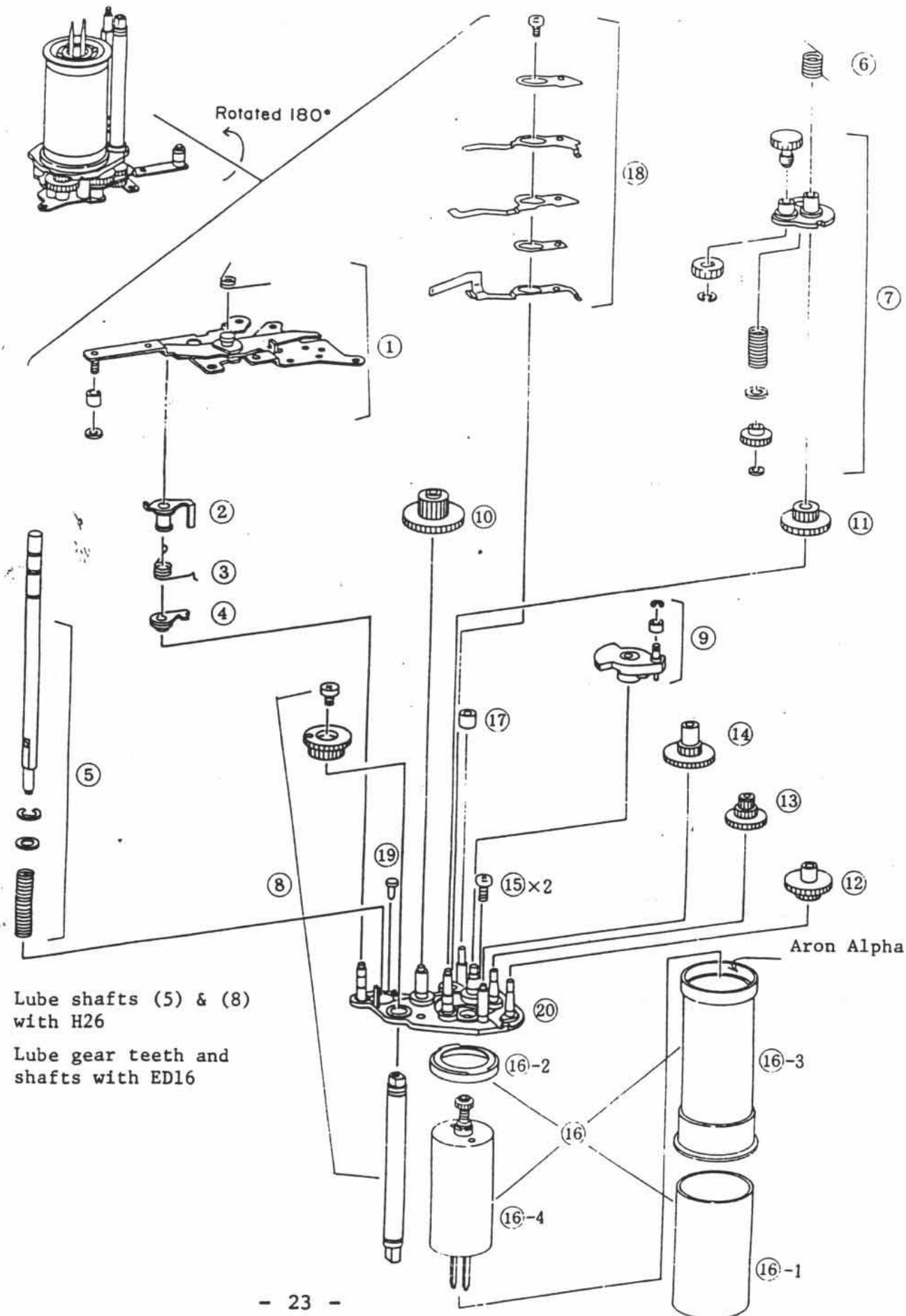

Fig. 3

I-9. Lower Winding Base



Lube shafts (5) & (8) with H26

Lube gear teeth and shafts with ED16

I. ASSEMBLY & DISASSEMBLY

I-9. Lower Winding Baseplate

Disassembly Notes

1. Since the lower winding baseplate-2 (1) and the lower winding baseplate (20) are only lightly welded together at three of the plastic studs, take care when removing the entire unit together. (The welding is an assembly procedure to improve assembly line efficiency. It is not structurally important).
2. Check the location of all parts before disassembly.
3. Spool collar (16)-2 is bonded to the spool (16)-3 during assembly. If it is necessary to separate them, they must be replaced.

Adjustment Notes

1. Bond the spool (16)-3 and collar (16)-2 with Aron Alpha.
2. Correctly position the alignment pin when installing the spool assembly (16), including the motor, on the baseplate (20).
3. Don't dirty the spool rubber. This will cause poor winding. Use alcohol (or Fronsolve AE) to clean the rubber.
4. Dress the leads from SW9 (18) as shown and bond with diabond. Leads must lay flat and not interfere with gears that mount above them. After installation, check that the switch operates properly. (If the switch does not make and break properly, the film transport bars will not appear on the LCD).

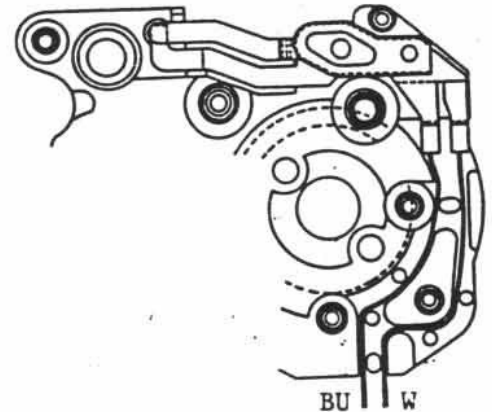

5. Lower Winding Gear Mesh

- 5.1. Align the mark on gear (10) with the leftmost hole in sector gear (9).
- 5.2. Put (9) against the stopper. [Take care with (17)].
- 5.3. Point the mark on gear (8) at the center of (10) and install it.

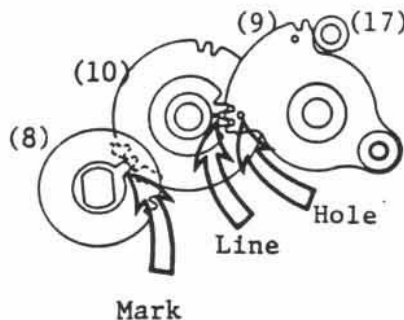

I. ASSEMBLY & DISASSEMBLY

I-9. Lower Winding Baseplate

Adjustment Notes

6. Install the lower winding baseplate-2 (1), otherwise known as the winding charge lever baseplate, onto the lower winding baseplate (20). (The back cover should be removed so (2) clears (1) when (1) is installed).

7. Overcharge Adjustment
 Standard: 0.9 to 1.2 f/stops
 7.1. Attach the AE Evaluation Tool Standard Lens (if available).
 7.2. Remove the winding stopper, and turn the winding gear clockwise. Read the f/number at the point where the reversal occurs.
 Adjust by changing the sector gear roller (A). If (A) does not provide sufficient adjustment, change collar (B).

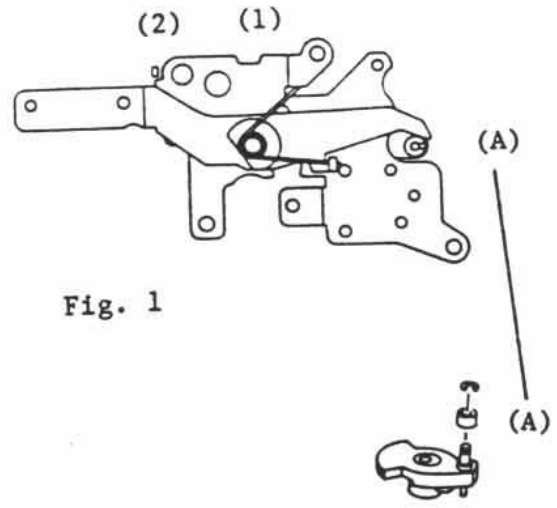

Fig. 1

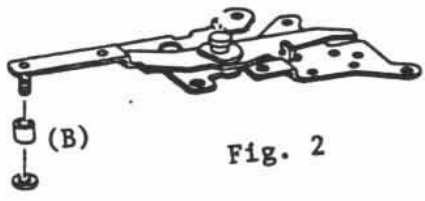

Fig. 2

8. Spool Torque Adjustment
 Standard: 200-250 gcm
 8.1. Adjust by changing gear (14) on page 19.
 8.2. Wind from 20 to 26cm of film onto the spool. Attach a tension gauge to the film and pull. The limit (in grams) is from 200 to 250 g.
 (With 5 to 6 frames wound (20 to 26 cm), the radius of the spool is approximately one cm.

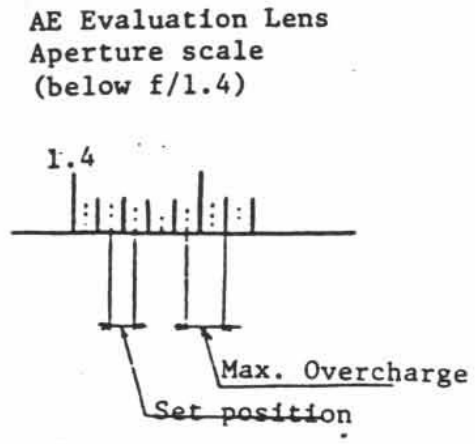

Fig. 3

C O N T E N T S

	Page	Address
I. ASSEMBLY & DISASSEMBLY		
Table of Contents	ii	A-4
II. ADJUSTMENTS		
II-1. Shutter	27	C-3
II-2. SPC Positioning	28	C-4
II-3. Gain, Level, and Level Shift	29	C-5
II.4. Inhibit voltage, Electronic Flash (EF) Changeover	31	C-7
II-5. Offset	32	C-8
II-6. SW4	33	C-9
III. OPERTING CURRENTS	34	C-10

35

31

II. ADJUSTMENTS

II-1. Shutter

CURTAIN TRAVEL TIME

Standard: $7.5 \pm 0.3\text{ms}$

X SYNC

Standard: A Line - 0.5ms or over
B Line - 2.5ms or over
C Line - N/A

SHUTTER SPEED: (Perform after Gain adjustment (pg. 29))

1. After the shutter is installed, only the first curtain travel time can be adjusted. (The adjustment is from the underside of the body, like the T50, but on the T70 the rewind gear assy. must also be removed).
2. Set the camera in TV mode at 1/1000 second.
Push the mode switch and ground "A" to change modes (up).
Push the mode switch and ground "B" to change modes (down).
In the TV mode, grounding "A" shifts the shutter speed up.
In the TV mode, grounding "B" shifts the speed down.
3. Adjust the 1/1000 second shutter speed with VR1.

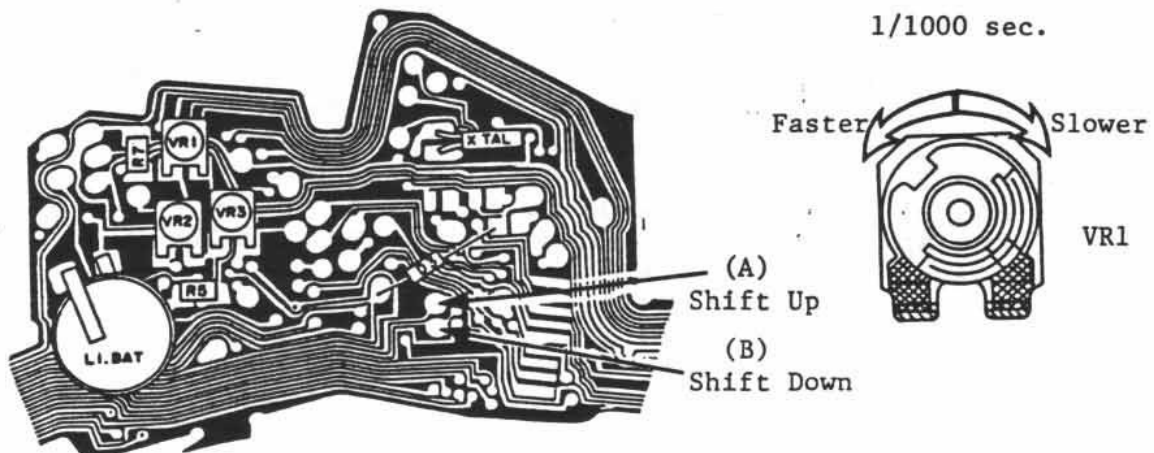

II. ADJUSTMENTS

II-2. SPC Positioning

ADJUSTMENTS:

1. Horizontal : Eccentric hex screw "A"
2. Vertical: Cross-recess screw "B"
3. Adjustment required only when ICl, the SPC holder, or the pentaprism frame have been changed. Otherwise, check only.
4. Eccentric "A" should be prepositioned as shown before starting. (This is to prevent tilting).

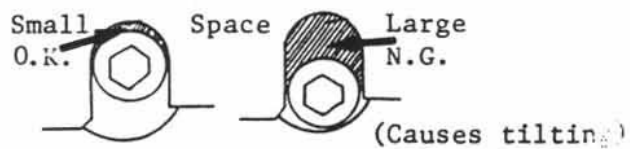
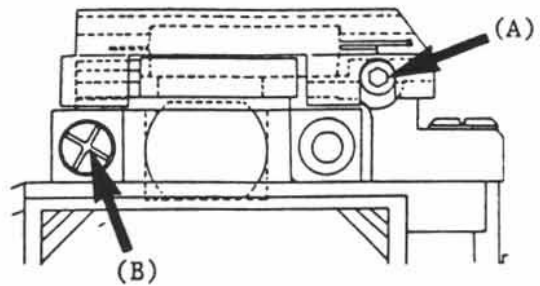

ADJUSTMENT:

1. Use an FD 50mm f/1.4 lens set at the closest distance.
2. Make a blind from opaque, dull colored card of most anything. It should be larger than the field of view at the closest distance (min.: 16 x 25cm) and have a circular 4mm hole in the middle. The purpose is to simulate a point light source.
3. Put the camera on a tripod directly in front of the light source (EF500, etc.). Hold the card directly in front of the light source, which should be set as bright as possible (EV15, normally).
4. Set the camera in the TV mode and metering to Partial.
5. Set the film and shutter speeds as necessary. (For best results, the room should be fairly dark).
6. Adjust the card so the point light source is centered in the split image and focus on the point source.
7. Adjust the camera so the f/number indicated in the viewfinder is f/1.8 or f/2.0. (Since selective area (partial) metering with AE lock is being used, SW1 must be released after each reading).

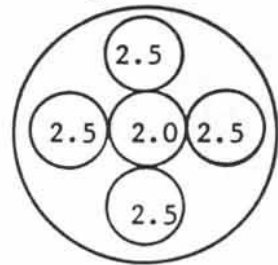

8. If the SPC is off to the left as shown, adjust the eccentric "A" . If it is off vertically, adjust "B".

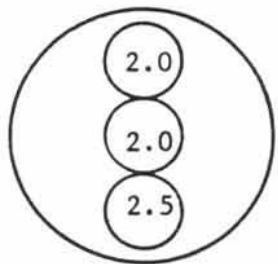
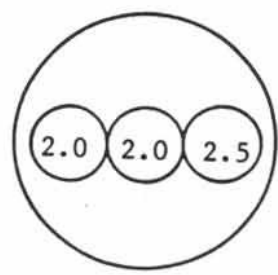

II. ADJUSTMENTS

II-3. Gain, Level, and Level Shift

With the T70, the LCD gives a read-out which is directly related to the EV felt by the camera. This read-out (explained in detail later) is used to adjust the camera exposure.

1. Gain and Level Adjustment

Gain is pre-adjusted when the electric parts unit is assembled. It need not be adjusted unless IC-3 is adjusted.

Use either the Tool Standard or shop standard FD 50mm f/1.4 lens set to the A mark.

Set the K value at 12.5 and check EV9 and EV15.

The settings of the film speed (ISO) and mode aren't important. (Ref: Fig. 1, 2, 3 and Tables 1 & 2 on this and following page)

1. Ground TP1 with a temporary jumper.
2. Ground TP2 to activate selective area (Partial) metering.
3. Set the selector to Average.
4. To adjust GAIN, read and record the LCD read-out for EV9 and EV15. Change R5 so the two are similar (If one is $-1/8$, they both should be). Increasing R5 resistance reduces gain slope and vice versa. (At this point, the read-out may not be exactly as shown in Table 1, but if it is not it should vary by the same amount in the same direction. For example, if the EV9 reading is $12 - 3/8$ instead of 13, the EV15 reading should be $4 - 3/8$ instead of 5).
5. Adjust the LEVEL with VR2 so the EV9 reading is within $\pm 1/8$ and the EV15 reading within $\pm 2/8$.

2. Level Shift (LS) Adjustment

The LS adjustment is used to match the exposure from selective area metering and from center weighted average metering.

1. After the GAIN and LEVEL adjustments, remove the ground from TP2. (Activates center-weighted average metering)
2. With VR3, adjust for EV9 brightness so the LCD read-out is the same as above (within $\pm 1/8$ EV).
3. Check EV15. (It should be within $\pm 2/8$ EV).

Fig. 1

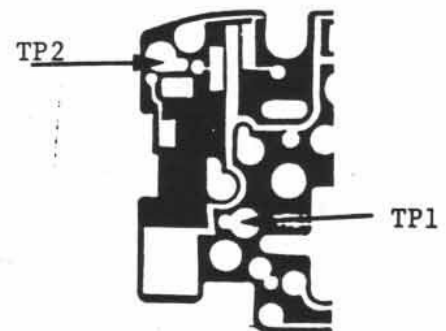

II. ADJUSTMENTS

II-3. Gain, Level, and Level Shift



図-2

R5 : Gain Adjustment
 VR2: Level Adjustment
 VR3: Level Shift Adjustment

EV	LCD
1	23
2	22
3	21
4	20
5	17
6	16
7	15
8	14
9	13
10	12
11	11
12	10
13	7
14	6
15	5
16	4
17	3
18	2

Table 1

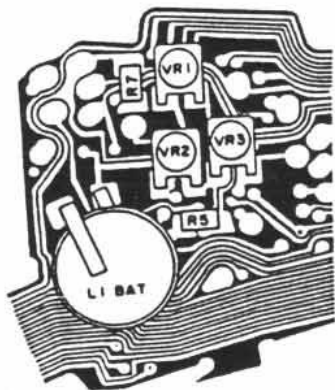
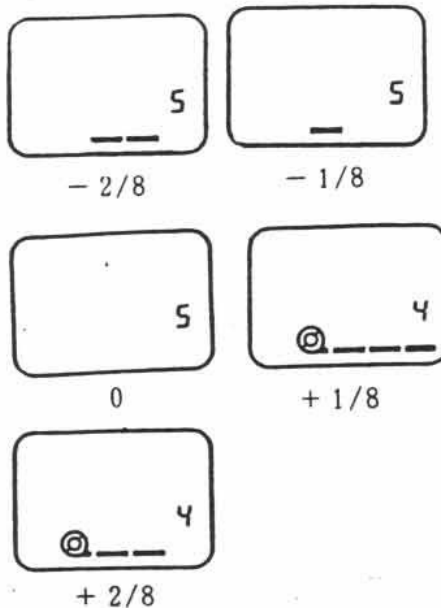

Standard
 EV9 \pm 1/8
 EV15 \pm 2/8

Fig. 3 Indication at EV15

EV	Indication
\pm 0	
- 1/8	
- 2/8	
- 3/8	
- 4/8	
- 5/8	
- 6/8	
- 7/8	

Table 2

II. ADJUSTMENTS

II-4. Inhibit voltage, Electronic Flash (EF) Changeover

INHIBIT VOLTAGE

Standard: 2.1 +0.2 v
 -0.15

1. Install the back LR03 cell to open the battery detection switch (SW3).
2. Attach leads to VBATT (+) and (-) and supply 2.1V (Fig. 1).
3. Remove R7 (Pg. 30, Fig. 2) and install a 40KOhm variable resistor.
4. Set the selector switch to SELF-TIMER.
5. Ground TP1 (Pg. 29, Fig. 1).
6. Watching the self-timer counter, adjust the variable resistor till the camera just stops working.
7. Remove and read the variable. Install an R7 of the nearest value to the variable.

ELECTRONIC FLASH (EF) Changeover (LCD Check)

1. Ground TP-1 (Pg. 29, Fig. 1).
2. Set the selector switch to PART(AE. L).
3. The LCD read-out should be $4 \pm 1/8$ (Pg. 30, Fig. 3).

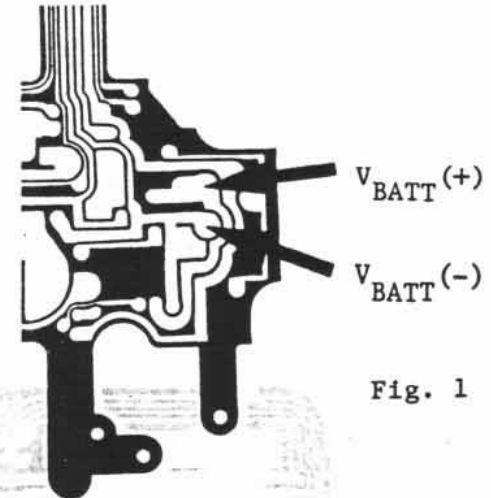

Fig. 1

(Viewfinder Check)

1. Install a 4.7 KOhm resistor from the CCC terminal to ground.
2. The viewfinder indication should be f/4.0 with the flash mark. The LCD should indicate 1/90sec.

If these standards are not met, find an adjusting resistor (R4) which causes the conditions to be met when installed from the EF land to either the KVC or GND land.

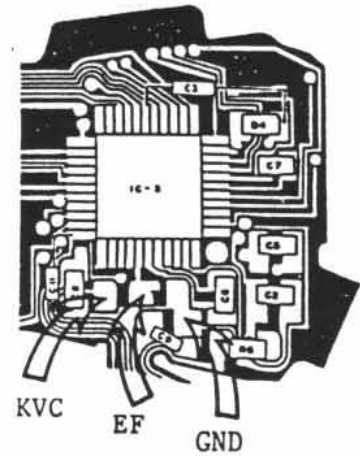

Fig. 2

II. ADJUSTMENTS

II-5. Offset

OFFSET

Offset adjustment is only necessary when IC1 has been changed.

Standard: IC1 p8 Voltage(V1) - IC1 p7 Voltage (V2)= 0 to 5mV

1. Remove RTC (R6) .
2. Short IC1 pin 10 to IC1 pin 7.
3. Read the voltage across pin 8 and ground. This is V1.
4. Read the voltage across pin 7 (MOS OUT) and ground. This is V2.
5. If $V1 - V2 = 0$ to 5mV , adjustment is not necessary.

If adjustment is necessary, proceed.

6. Install a 100KOhm variable resistor from ground to null 1 (1) or null 2 (2) in the figure below.
7. Adjust the resistor until V1-V2 is within tolerances.
8. Remove and read the variable resistor.
9. Install a fixed resistor as close as possible to the variable's resistance in the variable's position.
10. Remove the short across pins 10 and 7.
11. Reinstall RTC.

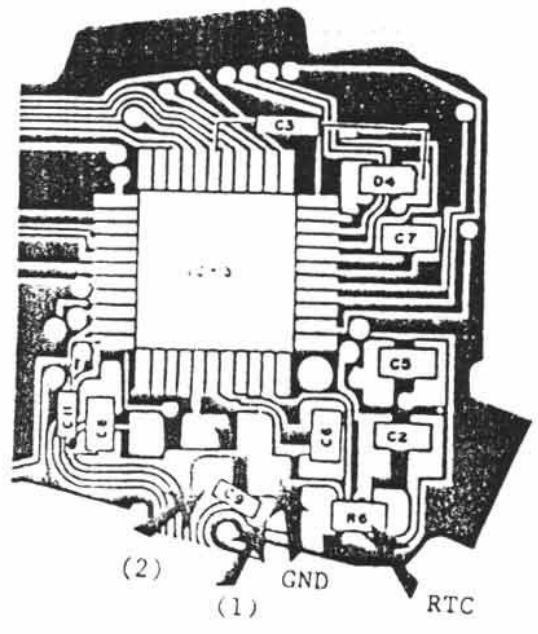
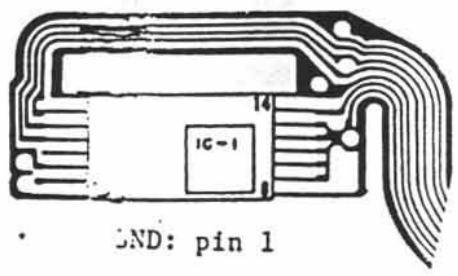

II. ADJUSTMENTS

II-6. SW4

This adjustment is necessary to prevent a dead spot because of switching overlap.

(Adjustment is made using spacers between the winding stop lever and gear).

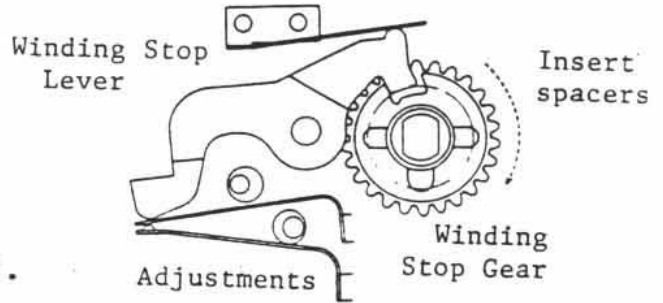

SW-1 and SW-M (Motor) Timing

1. With a 0.7mm spacer, SW4-1 and SW-M should both be off.
2. With a 1.0mm spacer, SW4-1 and SW-M should both be on.

SW4-2 and SW-M Timing

1. With a 0.45mm spacer, SW4-2 and SW-M should both be off.
2. Without the spacer, both SW4-2 and SW-M should be on.

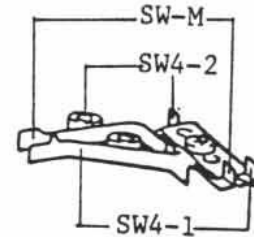

Eccentrics take a 0.9mm hex key.

After adjustment, the following requirements must all be met.



(A) = 0.4mm or over (B) = 0.5mm or over (C) = 0.5mm or over

Only if these conditions are met can correct operation be insured.

If both SW4-1 and SW4-2 are on at the same time, the power supply will be shorted and the camera will stop.

Use viewfinder focus adjusting washers as spacers.

III. OPERATING CURRENTS

(Power Supply: 3.3V regulated power supply)

Standards:

	(Less Than)
1. Camera Lock (off) or Stand-by:	100uA
2. Exposure Metering:	100mA
3. Winding (20th exp., lens = f/5.6)	680mA
4. Rewinding film	450mA
5. Rewinding time	25 sec.

S E R V I C E T O O L S L I S T

C A N O N T 7 0

MEASUREMENT

TEST EQUIPMENT

- 1. Shutter EF 500AC Multi-Exposure Tester
- 2. Exposure Meter
 - 2.1 Canon Light Source-4 (2854K)
 - 2.2 D.C. Voltage Tester (1mV, 1uA specs.)
 - 2.3 Ohmmeter
 - 2.4 Standard Brightness Checker (CdS) or Canon Luminance Meter (SBC)
 - 2.5 Multi Camera Tester EF-500AC
- 3. Viewfinder Universal 600mm Range-viewfinder Collimator or equivalent.
- 4. Electrical Adjustments
 - 4.1 Digital Multimeter (DMM)
 - 4.2 Oscilloscope
 - 4.3 Regulated Voltage Power Supply (LVPS)
 - 4.4 Ohmmeter
 - 4.5 AE Standard Tool Lens
- 5. Mirror angle (45°)
 - 5.1 Universal Type 90° Collimator or
 - 5.2 Simplified 90° Collimator
- 6. Flange to Focal Plane Distance (FFD) 42.14mm Dial Gauge Set
- 7. Mechanical
 - 7.1 Dial Tension Gauge-600g
 - 7.2 Depth Micrometer*
 - 7.3 2.5mm Hex Key (Mirror Angle)
 - 7.4 0.9mm Hex Key (SPC Position, SW-4 Adj)

* : Local Purchase

REF. NO. CI2-1842-000

CANON T70

CONTENTS

	PAGE	ADDRESS
EXTERNAL PARTS	1	A-7,8
TOP COVER PARTS	2	A-9,10
BACK COVER & LCD PARTS	3	A-11,12
ELECTRIC PARTS UNIT	4	A-13,14
FINDER PARTS	5	B-1,2
MIRROR BOX PARTS	6	B-3,4
MIRROR MECHANISM, AUTO DIAPHRAGM & AE UNIT	7	B-5,6
REWIND GEAR & LATCH MECHANISM	8	B-7,8
SWITCH & GEAR MECHANISM	9	B-9,10
SPROCKET PARTS & ROLLER HOLDER UNIT	10	B-11,12
MOTOR & GEAR MECHANISM	11	B-13,14
SHUTTER UNIT	12	C-1,2
WINDING DIAGRAM	13	C-3,4
ELECTRIC PARTS LIST	14	C-5
ELECTRIC PARTS LIST	15	C-6
INDEX OF PART NUMBERS	16 -	C-7 -

84.03

T70 SERVICE PARTS POLICY

1. THE POLICY OF CAMERA SERVICE, TOKYO, IS TO STOCK ALL PARTS NECESSARY TO EFFECT EFFICIENT ECONOMICAL SERVICE. IT IS NEITHER NECESSARY NOR TECHNICALLY FEASIBLE TO STOCK SEPARATELY EVERY PART THAT GOES INTO EACH PRODUCT.

IN ESTABLISHING THE SPARE PARTS LIST, WE CONSIDER REPAIR DIFFICULTY, LABOR COST, SPECIAL TOOL REQUIREMENTS AND INDIVIDUAL PARTS Vs. ASSEMBLED UNIT COST TO DETERMINE IN WHICH FORM PARTS WILL BE STOCKED.

2. A RECENT REVIEW HAS SHOWN THAT IT IS MORE ECONOMICAL AND ADVANTAGEOUS TO THE CUSTOMER, THE SERVICE FACILITY AND US TO STOCK INDIVIDUAL PARTS UNLESS THERE IS AN OVERRIDING REASON FOR STOCKING PRE-ASSEMBLED UNITS.

THE UNITS LISTED BELOW ARE STOCKED AS UNITS BECAUSE THEY REQUIRE TOOLS OR TECHNICS NOT NORMALLY AVAILABLE AT FIELD SERVICE LEVEL.

CY1-1157-000	SHUTTER FLEX	CY1-1171-000	SPOOL GEAR ASSY
CY1-1163-000	EYEPIECE	CY1-1172-000	MOTOR UNIT
CY1-1164-000	COVER, BATTERY		

IN ADDITION TO THE ABOVE, WHICH ARE STOCKED ONLY AS UNITS, SOME INDIVIDUAL PARTS ARE STOCKED FOR THE FOLLOWING UNITS IN ADDITION TO THE UNIT.

CG1-0218-000	TOP COVER UNIT	CG1-0227-000	AE UNIT
CG1-0219-000	BACK COVER UNIT	CG1-0228-000	SHUTTER UNIT
CG1-0222-000	ELECTRIC PARTS UNIT	CG9-2636-000	REMOTE CONTROL JACK UNIT
CG1-0225-000	MIRROR MECHANISM		
CG1-0226-000	AUTO DIAPHRAGM UNIT		

3. INDIVIDUAL ELECTRICAL COMPONENTS WHICH MAY REQUIRE REPLACEMENT ARE STOCKED.

4. THE SPARE PARTS LIST IS ADJUSTED PERIODICALLY TO INSURE THE NECESSARY PARTS ARE ALWAYS AVAILABLE, AND UNNECESSARY PARTS ARE REMOVED FROM THE STOCK LIST.

5. ASSEMBLIES SHOWN WITH THE N.S. MARK ARE SHOWN FOR CLARITY ONLY. THEY ARE NOT STOCKED IN THE FORM SHOWN.

キヤノン T70 サービス部品について

サービス部品は修理上の精度、工数、コスト、部品の使用頻度等、諸々の事由を勘案し、設定している。

特にユニット部品の構成部品中で、使用頻度の少ないものは、サービス部品とはしない。キヤノンT70においては次のような部品設定とする。

下記部品はユニットのみをサービス部品とする。

CY1-1157-000	シャッターフレキユニット	CY1-1164-000	電池蓋ユニット
CY1-1163-000	接眼	CY1-1171-000	スプールギア
		CY1-1172-000	モーター

下記部品はユニット及び使用頻度の高いと考えられる部品をサービス部品とする。

CG1-0218-000	上蓋ユニット	CG1-0227-000	AE 抵抗ユニット
CG1-0219-000	背蓋ユニット	CG1-0228-000	シャッターユニット
CG1-0222-000	電気部品ユニット	CG9-2636-000	底蓋ユニット
CG1-0225-000	ミラーQRユニット		
CG1-0226-000	自動絞りユニット		

電気素子は一部のもの以外は、サービス部品としないが修理時のチェックが出来るよう定格を明示している。

※ 当初、サービス部品設定されない部品でも状況に応じ、サービス部品として、追加することもある。

※ ユニットの一部分でサービス部品としないものは N.S マークをつけてある。

以上

CANON T70

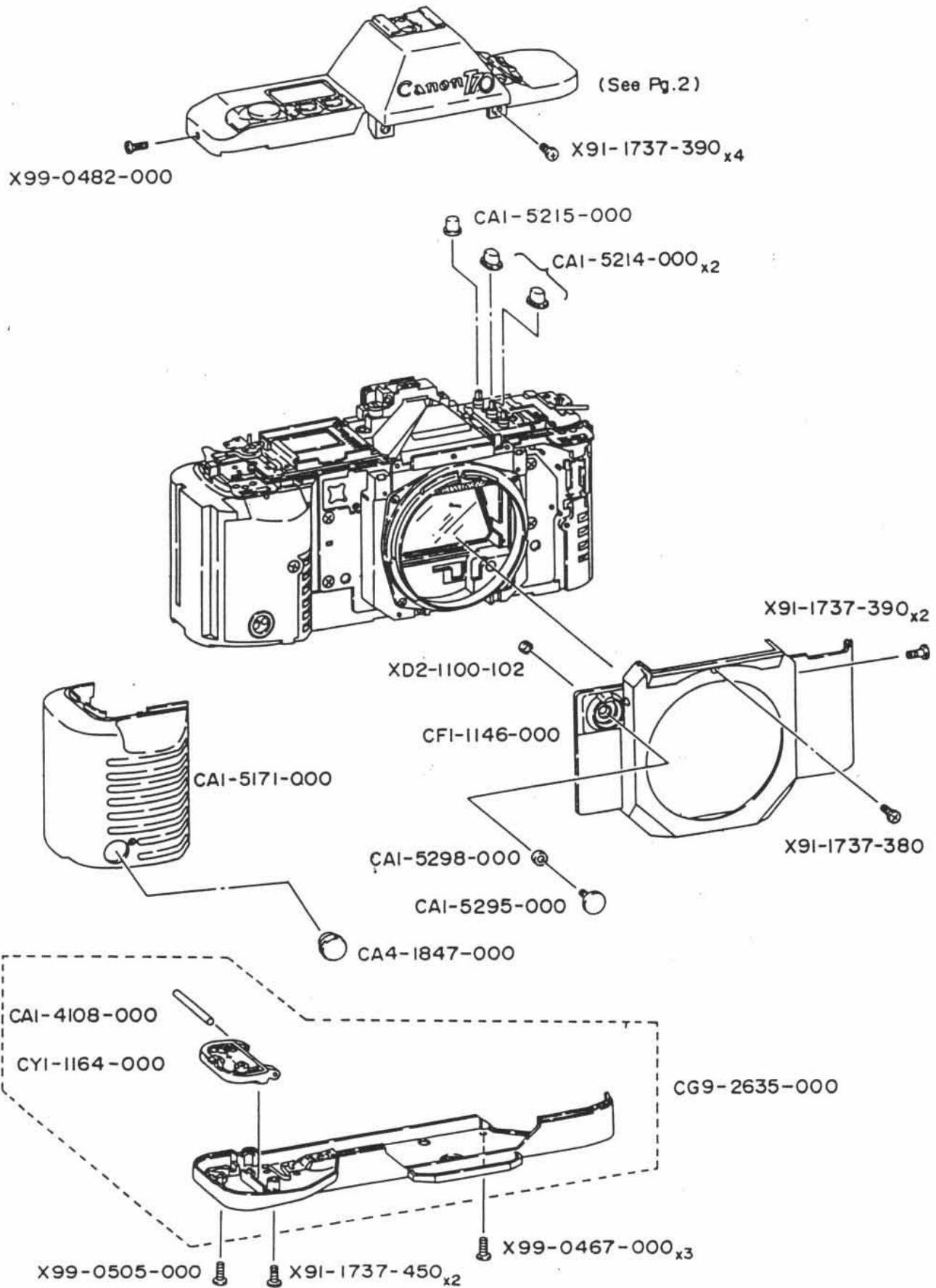

PARTS LIST

EXTERNAL PARTS

MARK	PART NO.	CLASS	QTY	DESCRIPTION
	CA1-4108-000	D	1	SHAFT, HINGE
	CA1-5171-000	C	1	COVER, GRIP
	CA1-5214-000	D	2	BUTTON
	CA1-5215-000	D	1	BUTTON, B.C.
	CA1-5295-000	D	1	BUTTON
	CA1-5298-000	E	1	COLLAR
	CA4-1847-000	D	1	CAP, TERMINAL
	CF1-1146-000	B	1	COVER, FRONT
	CG9-2635-000	B	1	BASE COVER UNIT
	CY1-1164-000	C	1	COVER, BATTERY
	XD2-1100-102		1	E RING
	X91-1737-380		1	SCREW, CROSS-RECESS, PH
	X91-1737-390		6	SCREW, CROSS-RECESS, PH
	X91-1737-450		2	SCREW, CROSS-RECESS, PH
	X99-0467-000		3	SCREW, CROSS-RECESS, PH
	X99-0482-000		1	SCREW, CROSS-RECESS, PH
	X99-0505-000		1	SCREW, CROSS-RECESS, PH

CANON T70

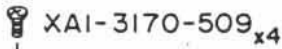

CAI-5312-000 detail

A	SIZE
8.15mm	(081)
8.30mm	(083)
8.40mm	(084)

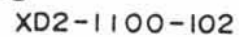
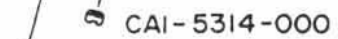
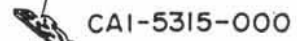
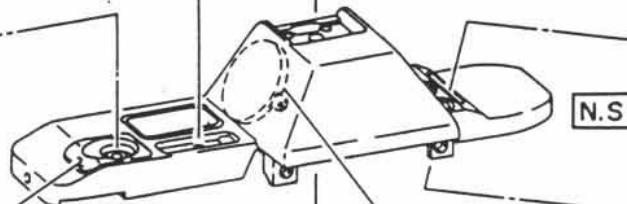
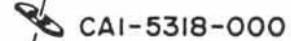
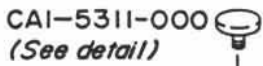
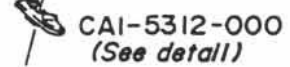
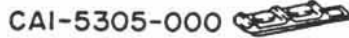
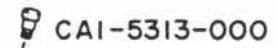
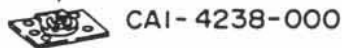

CAI-5311-000 detail

A	SIZE
5.3mm	(053)
5.5mm	(055)
5.7mm	(057)

84

47

REF. NO. C12-1842-000

2

PARTS LIST

TOP COVER PARTS

MARK	PART NO.	CLASS	QTY	DESCRIPTION
	CA1-1374-000	B	1	SHOE, ACCESSORY
	CA1-3385-000	C	1	SPRING, PLATE (BL)
	CA1-4238-000	B	1	BASE, ACCESSORY SHOE
	CA1-5304-000	E	1	SEAT, SHUTTER BUTTON
	CA1-5305-000	D	1	SWITCH, SHIFT UP & DOWN
	CA1-5306-000	E	1	SHIELD, LIGHT
	CA1-5311-000	D	1	BUTTON, RELEASE
	(ENTER SIZE WHEN ORDERING, SEE DETAIL)			
	CA1-5312-000	D	1	LEVER, SELECTOR
	(ENTER SIZE WHEN ORDERING, SEE DETAIL)			
	CA1-5313-000	D	1	BUTTON, SELECTOR
	CA1-5314-000	E	1	NUT
	CA1-5315-000	D	1	SPRING, LOCK
	CA1-5316-000	D	1	PLATE, MOUNTING
	CA1-5318-000	D	1	SHEET
	CF1-1278-000	E	1	BEEPER
	CG1-0218-000	B	1	TOP COVER UNIT
	XA1-3170-509		4	SCREW, CROSS-RECESS, FCH
	XD2-1100-102		1	E RING
	XD2-1200-152		1	E RING

CANON T70

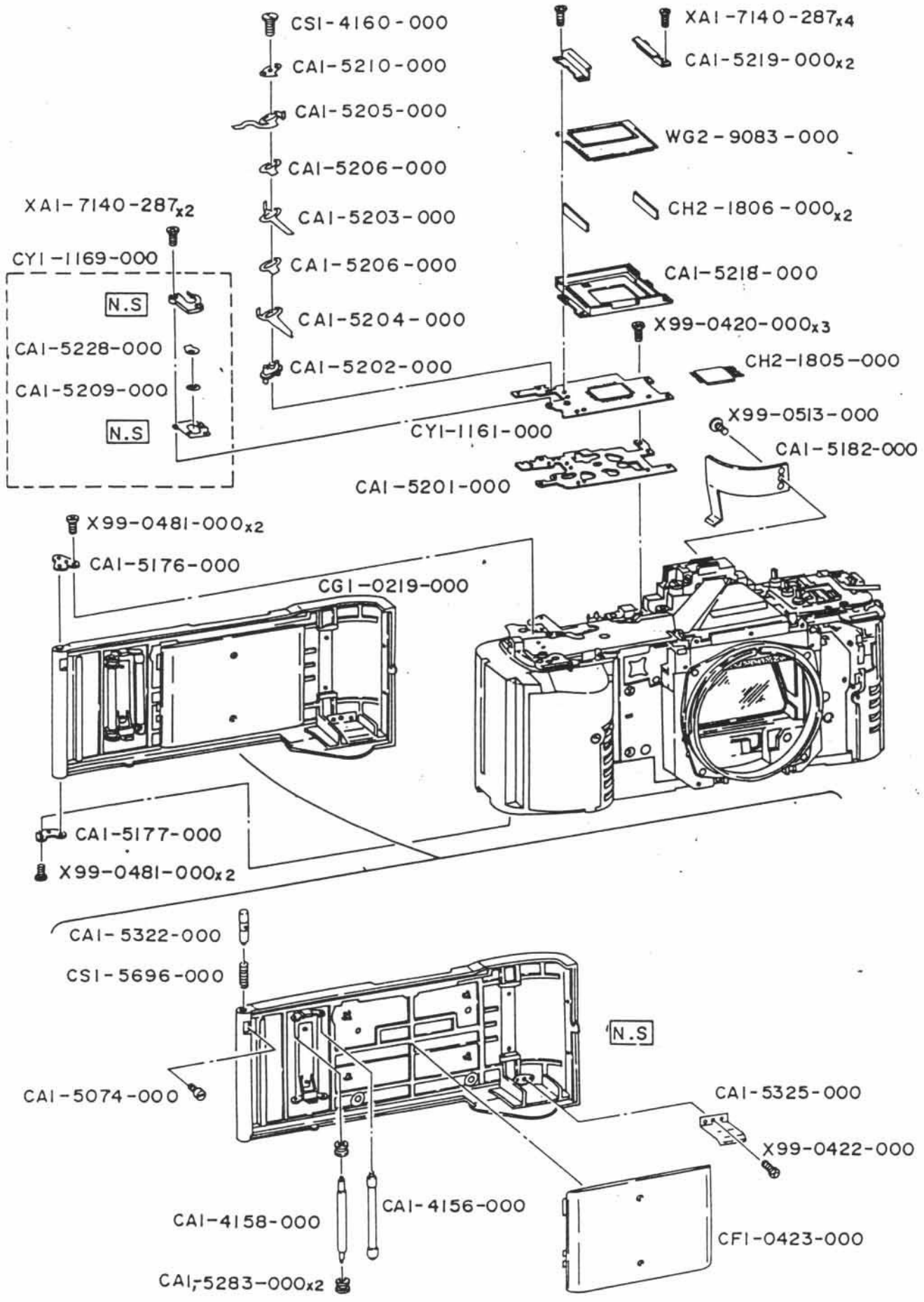

PARTS LIST

BACK COVER & LCD PARTS

MARK	PART NO.	CLASS	QTY	DESCRIPTION
	CA1-4156-000	D	1	FILM GUIDE
	CA1-4158-000	D	1	ROLLER
	CA1-5074-000	E	1	SCREW, STOPPER
	CA1-5176-000	E	1	HINGE, UPPER
	CA1-5177-000	E	1	HINGE, LOWER
	CA1-5182-000	D	1	GUIDE, CASSETTE
	CA1-5201-000	E	1	BASE, LCD
	CA1-5202-000	D	1	BASE, CONTACT
	CA1-5203-000	D	1	CONTACT, RELEASE
	CA1-5204-000	D	1	CONTACT, RELEASE
	CA1-5205-000	D	1	CONTACT, RELEASE
	CA1-5206-000	D	2	INSULATOR
	CA1-5209-000	E	1	CONTACT, CLICK
	CA1-5210-000	D	1	INSULATOR
	CA1-5218-000	D	1	CASE, LCD
	CA1-5219-000	D	2	HOLDER, LCD
	CA1-5228-000	E	1	COVER, SW2
	CA1-5283-000	E	2	ROLLER
	CA1-5322-000	D	1	SHAFT, HINGE
	CA1-5325-000	D	1	SPRING, PLATE
	CF1-0423-000	D	1	PLATE, PRESSURE
	CG1-0219-000	C	1	BACK COVER UNIT
	CH2-1805-000	D	1	CABLE, FLAT (9)
	CH2-1806-000	D	2	CONNECTOR
	CS1-4160-000	D	1	SCREW
	CS1-5696-000	D	1	SPRING, COIL
	CY1-1161-000	C	1	ELECTRIC PARTS UNIT
	CY1-1169-000	D	1	STOPPER, RELEASE
	WG2-9083-000	E	1	LCD
	XA1-7140-287		6	SCREW, CROSS-RECESS, PH
	X99-0420-000		3	SCREW, CROSS-RECESS, PH
	X99-0422-000		1	SCREW, CROSS-RECESS, PH
	X99-0481-000		4	SCREW, CROSS-RECESS, PH
	X99-0513-000		1	SCREW, CROSS-RECESS, PH

CANON T70

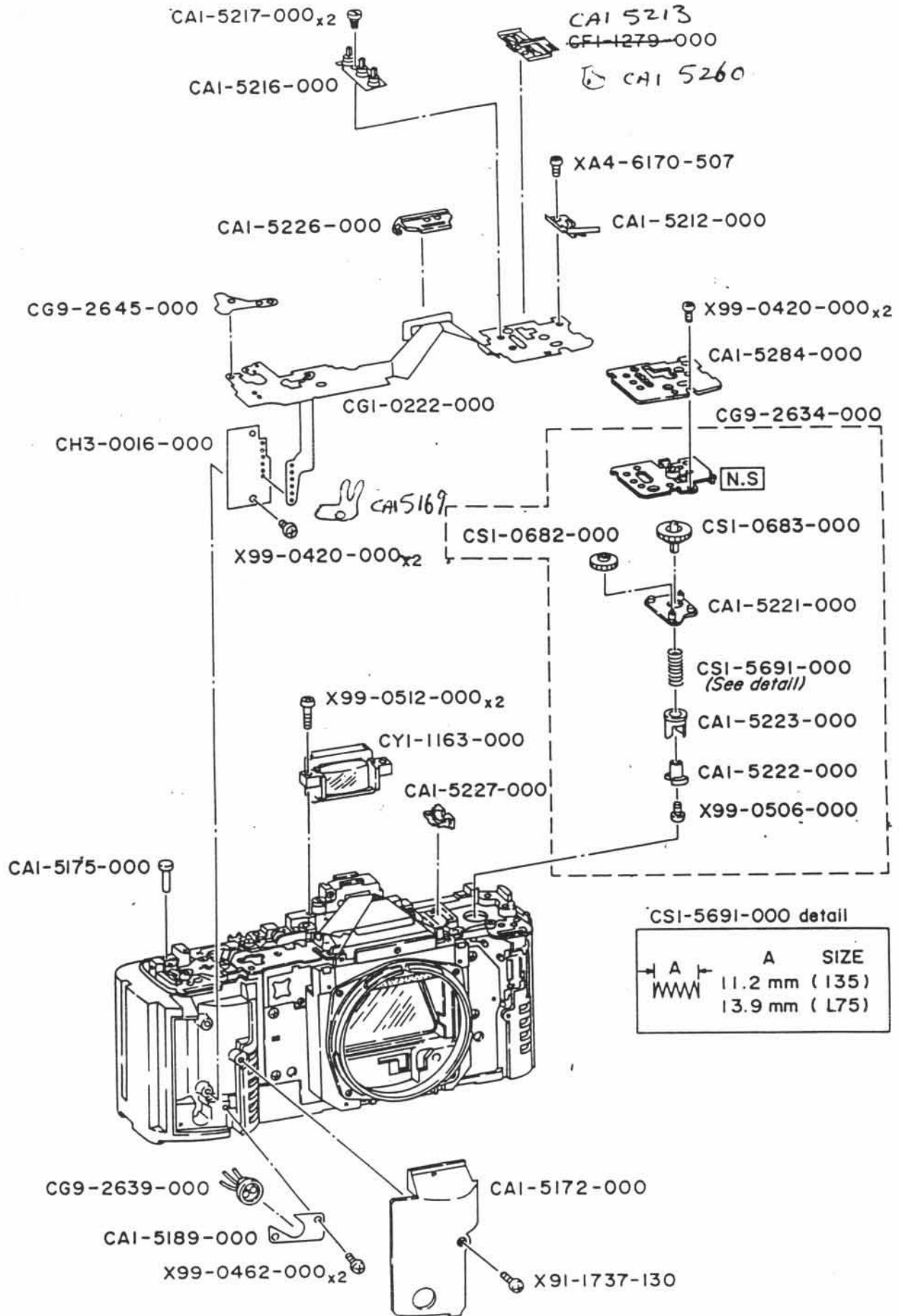

PARTS LIST

ELECTRIC PARTS UNIT

MARK	PART NO.	CLASS	QTY	DESCRIPTION
	CA1-5172-000	E	1	SPACE, GRIP
	CA1-5175-000	E	1	PIN, BATTERY SENSOR
	CA1-5189-000	E	1	HOLDER, JACK
	CA1-5212-000	E	1	CONTACT, AL
	CA1-5216-000	E	1	RUBBER, CONDUCTION
	CA1-5217-000	D	2	SCREW
	CA1-5221-000	E	1	BASE, REWIND
	CA1-5222-000	E	1	SHAFT, HOOK
	CA1-5223-000	E	1	FORK, REWIND
	CA1-5226-000	E	1	PLATE, STOPPER
	CA1-5227-000	E	1	HOLDER, FLAT CABLE (6)
	CA1-5284-000	E	1	INSULATOR
CA15213	CF1-1279-000	D	1	CONTACT, SELECTOR
	CG1-0222-000	B	1	ELECTRIC PART UNIT
	CG9-2634-000	E	1	REWINDING UNIT
	CG9-2639-000	E	1	REMOTE CONTROL JACK UNIT
	CG9-2645-000	E	1	SUB FLX
	CH3-0016-000	D	1	CONVERTER, DC/DC
	CS1-0682-000	E	1	GEAR
	CS1-0683-000	E	1	GEAR
	CS1-5691-000	E	1	SPRING, COIL
	(ENTER SIZE WHEN ORDERING, SEE DETAIL)			
	CY1-1163-000	B	1	EYEPIECE
	XA4-6170-507		1	SCREW, CROSS-RECESS, PH
	X91-1737-130		1	SCREW, CROSS-RECESS, PH
	X99-0420-000		4	SCREW, CROSS-RECESS, PH
	X99-0462-000		2	SCREW, CROSS-RECESS, PH
	X99-0506-000		1	SCREW, CROSS-RECESS, PH
	X99-0512-000		2	SCREW, CROSS-RECESS, PH
	CA15260			INSULATOR
	CA15169			EARTH LUG

CANON T70

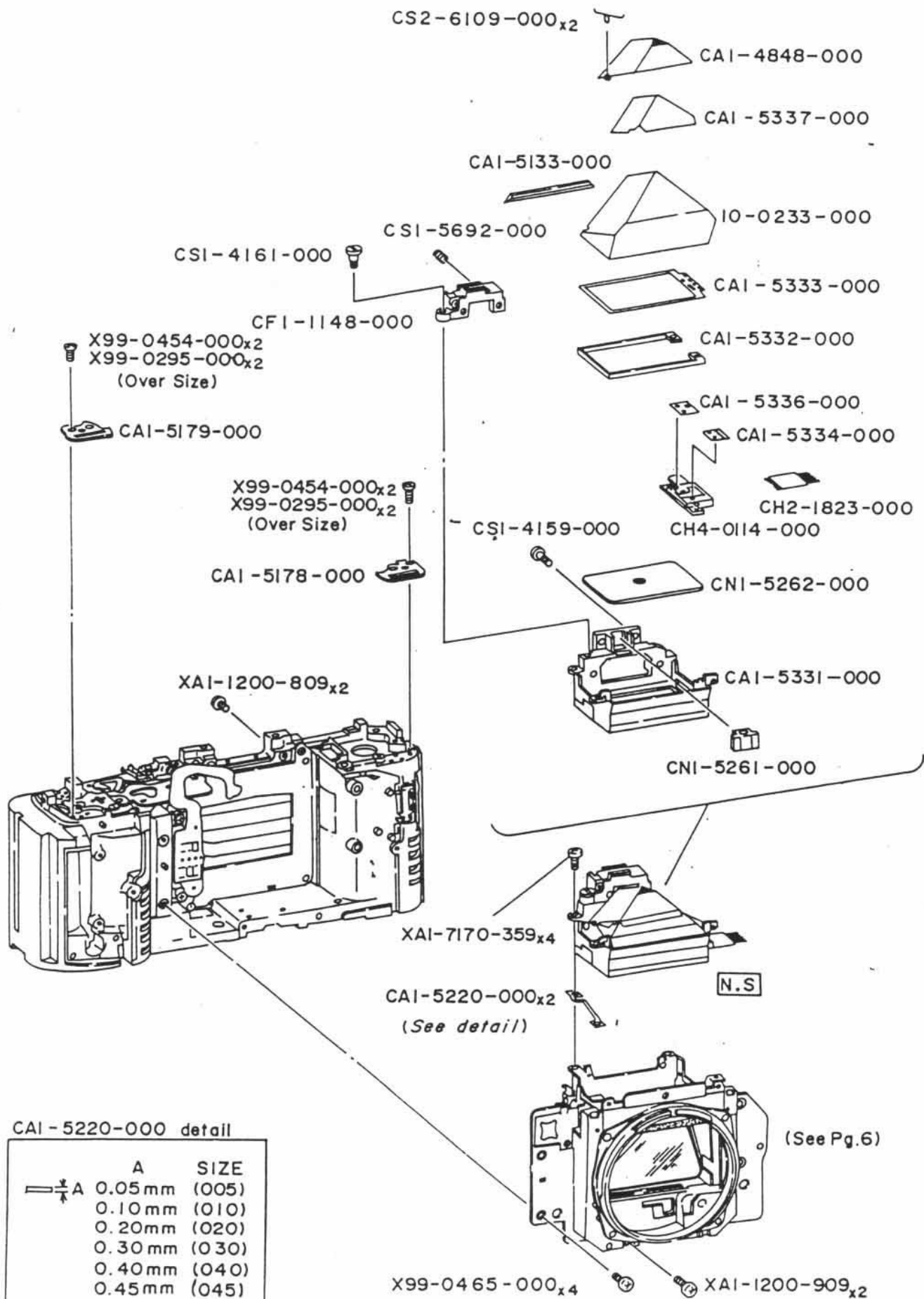

CAI-5220-000 detail

A	SIZE
$\frac{A}{10}$	0.05mm (005)
$\frac{A}{10}$	0.10mm (010)
$\frac{A}{10}$	0.20mm (020)
$\frac{A}{10}$	0.30mm (030)
$\frac{A}{10}$	0.40mm (040)
$\frac{A}{10}$	0.45mm (045)

PARTS LIST

FINDER PARTS

MARK	PART NO.	CLASS	QTY	DESCRIPTION
	10-0233-000	C	1	PENTAPRISM
	CA1-4848-000	E	1	HOLDER, PENTAPRISM
	CA1-5133-000	D	1	SPACE
	CA1-5178-000	D	1	LUG, NECK STRAP
	CA1-5179-000	D	1	LUG, NECK STRAP
	CA1-5220-000	E	2	WASHER, ADJUSTING
	(ENTER SIZE WHEN ORDERING, SEE DETAIL)			
	CA1-5331-000	E	1	BOX, PENTAPRISM
	CA1-5332-000	E	1	SPACE
	CA1-5333-000	E	1	MASK, FINDER
	CA1-5334-000	E	1	MASK, INDICATOR
	CA1-5336-000	E	1	MASK, LED
	CA1-5337-000	E	1	COVER, PENTAPRISM
	CF1-1148-000	E	1	HOLDER, SPC
	CH2-1823-000	D	1	CABLE, FLAT (6)
	CH4-0114-000	D	1	LED
	CN1-5261-000	E	1	LENS/PRISM, SPC
	CN1-5262-000	C	1	SCREEN, FOCUSING
	CS1-4159-000	E	1	SCREW
	CS1-4161-000	E	1	SCREW
	CS1-5692-000	E	1	SPRING, COIL
	CS2-6109-000	D	2	SPRING
	XA1-1200-809		2	SCREW, CROSS-RECESS, PH
	XA1-1200-909		2	SCREW, CROSS-RECESS, PH
	XA1-7170-359		4	SCREW, CROSS-RECESS, PH
	X99-0295-000		4	SCREW, CROSS-RECESS, PH
	X99-0454-000		4	SCREW, CROSS-RECESS, PH
	X99-0465-000		4	SCREW, CROSS-RECESS, PH

CANON T70

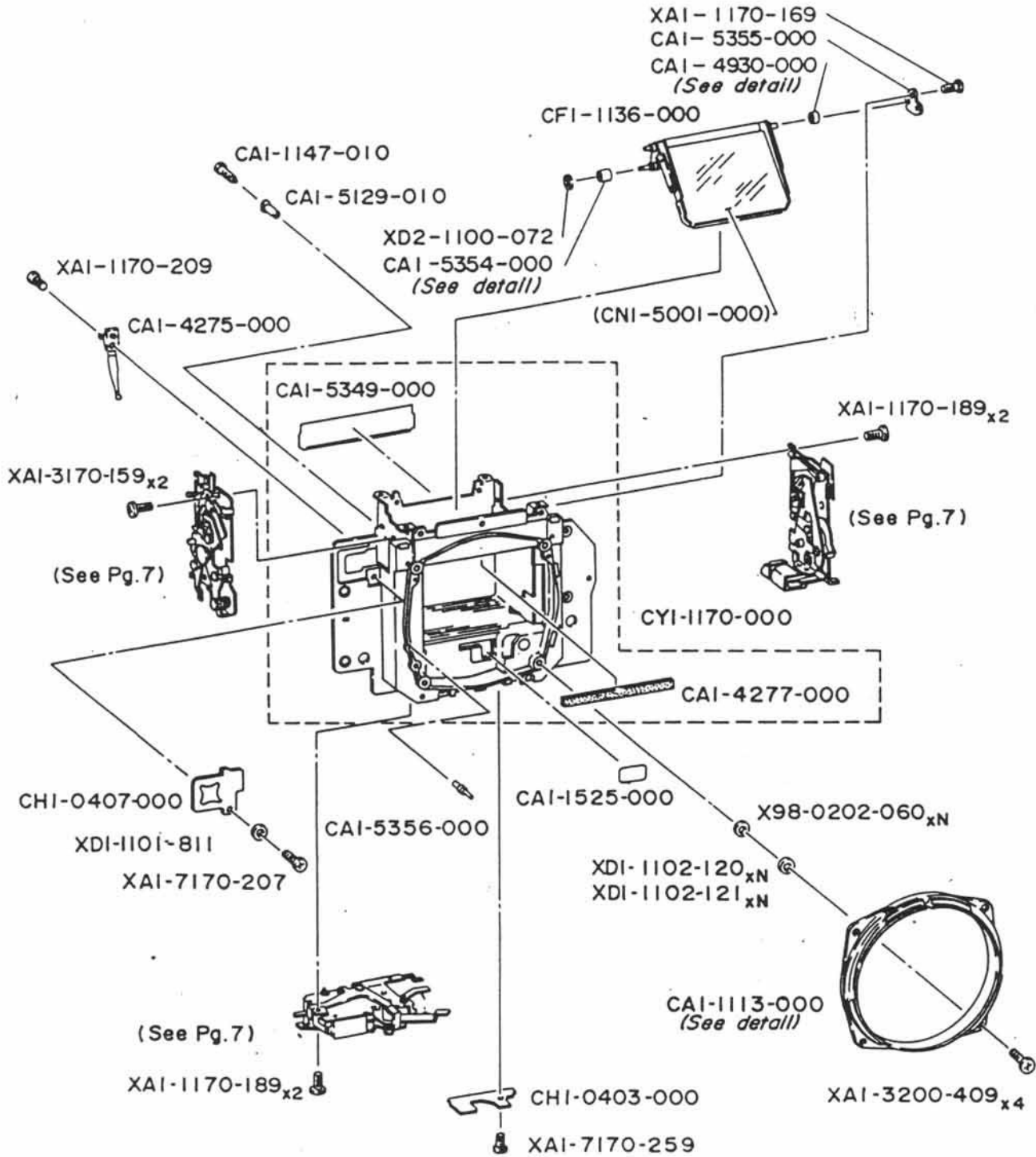

CAI-4930-000 detail

A	A	SIZE
	1.15mm	(115)
	1.25mm	(125)
	1.35mm	(135)

CAI-5354-000 detail

A	SIZE
	φ20 mm (050)H0
	φ21 mm (040)C30
	φ22 mm (030)C20
	φ24 mm (020)C10
	φ22 mm (010)

CAI-1113-000 detail

A	SIZE
	5.3mm (000): Standard
	5.1mm (001):
	Special service part (0.2mm under standard)

PARTS LIST

MIRROR BOX PARTS

MARK	PART NO.	CLASS	QTY	DESCRIPTION
	CA1-1113-000	D	1	BODY MOUNT
	CA1-1113-000(001)	E	1	BODY MOUNT (SERVICE ONLY)
	CA1-1147-010	D	1	SCREW, MAX. APERTURE CORRECT.
	CA1-1525-000	B	1	SHIELD, LIGHT
	CA1-4275-000	D	1	CONTACT, A.M
	CA1-4277-000	D	1	CUSHION
	CA1-4930-000	E	1	COLLAR
	(ENTER SIZE WHEN ORDERING, SEE DETAIL)			
	CA1-5129-010	D	1	PIN, MAX. APERTURE CORRECTION
	CA1-5349-000	E	1	SHIELD, LIGHT
	CA1-5354-000	E	1	COLLAR
	(ENTER SIZE WHEN ORDERING, SEE DETAIL)			
	CA1-5355-000	E	1	PLATE, ADJUSTING
	CA1-5356-000	E	1	PIN, A.M
	CF1-1136-000	C	1	MIRROR ASSY
	CH1-0403-000	E	1	BOARD, PRINTED CIRCUIT
	CH1-0407-000	E	1	BOARD, PRINTED CIRCUIT
	CN1-5001-000	A	1	MIRROR
	CY1-1170-000	E	1	PANEL, FRONT
	XA1-1170-169		1	SCREW, CROSS-RECESS, PH
	XA1-1170-189		4	SCREW, CROSS-RECESS, PH
	XA1-1170-209		1	SCREW, CROSS-RECESS, PH
	XA1-3170-159		2	SCREW, CROSS-RECESS, FCH
	XA1-3200-409		4	SCREW, CROSS-RECESS, FCH
	XA1-7170-207		1	SCREW, CROSS-RECESS, PH
	XA1-7170-259		1	SCREW, CROSS-RECESS, PH
	XD1-1101-811		1	WASHER
	XD1-1102-120		1	WASHER
	XD1-1102-121		1	WASHER
	XD2-1100-072		1	E RING
	X98-0202-060		1	WASHER

CANON T70

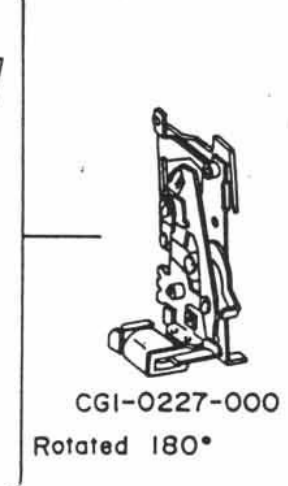
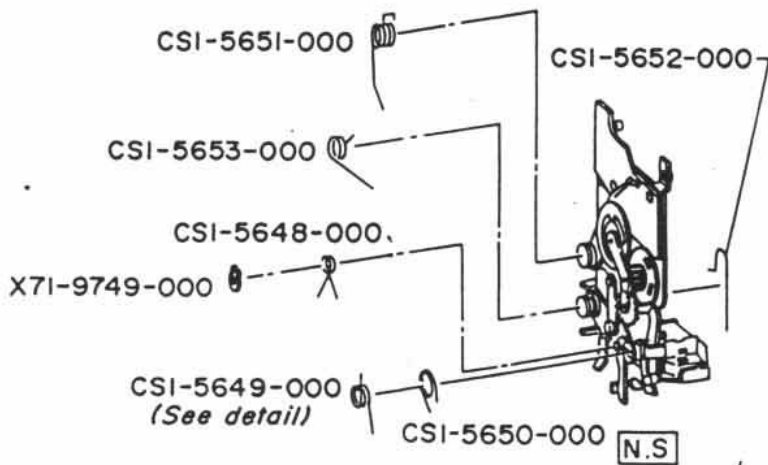
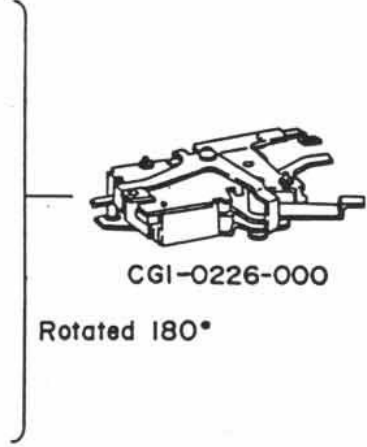
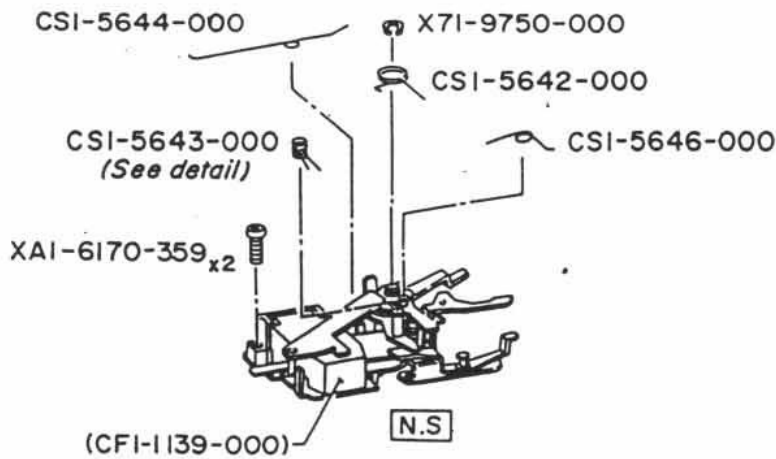
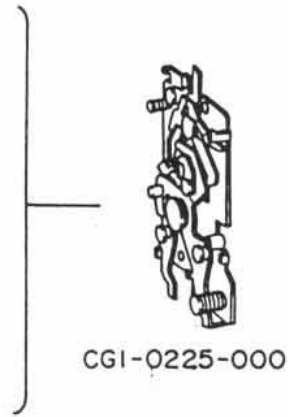
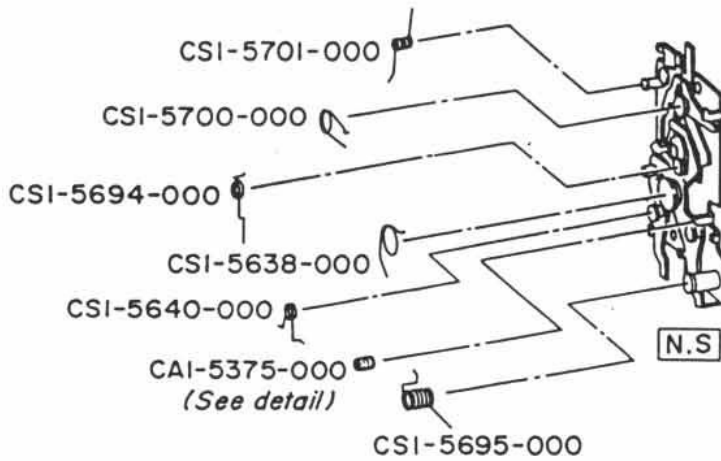

CAI-5375-000 detail

A	SIZE
	φ 2.1 (010)
	φ 2.4 (020)
	φ 2.7 (030)

CSI-5643-000 detail

A	SIZE
	180° (010)
	175° (020)
	170° (030)
	165° (040)

CSI-5649-000 detail

A	SIZE
	146° (010)
	151° (020)

PARTS LIST

MIRROR MECHANISM, AUTO DIAPHRAGM & AE UNIT

MARK	PART NO.	CLASS	QTY	DESCRIPTION
	CA1-5375-000	E	1	RUBBER, COLLAR
	(ENTER SIZE WHEN ORDERING, SEE DETAIL)			
	CF1-1139-000	E	1	MAGNET NO.2 ASSY
	CG1-0225-000	D	1	MIRROR MECHANISM UNIT
	CG1-0226-000	D	1	AUTO DIAPHRAGM UNIT
	CG1-0227-000	D	1	AE UNIT
	CS1-5638-000	E	1	SPRING
	CS1-5640-000	E	1	SPRING
	CS1-5642-000	E	1	SPRING
	CS1-5643-000	E	1	SPRING
	(ENTER SIZE WHEN ORDERING, SEE DETAIL)			
	CS1-5644-000	E	1	SPRING
	CS1-5646-000	E	1	SPRING
	CS1-5648-000	E	1	SPRING
	CS1-5649-000	E	1	SPRING
	(ENTER SIZE WHEN ORDERING, SEE DETAIL)			
	CS1-5650-000	E	1	SPRING
	CS1-5651-000	E	1	SPRING
	CS1-5652-000	E	1	SPRING
	CS1-5653-000	E	1	SPRING
	CS1-5694-000	E	1	SPRING
	CS1-5695-000	E	1	SPRING
	CS1-5700-000	E	1	SPRING
	CS1-5701-000	E	1	SPRING
	XA1-6170-359		2	SCREW, CROSS-RECESS, PH
	X71-9749-000		1	RETAINER
	X71-9750-000		1	RETAINER

CANON T70

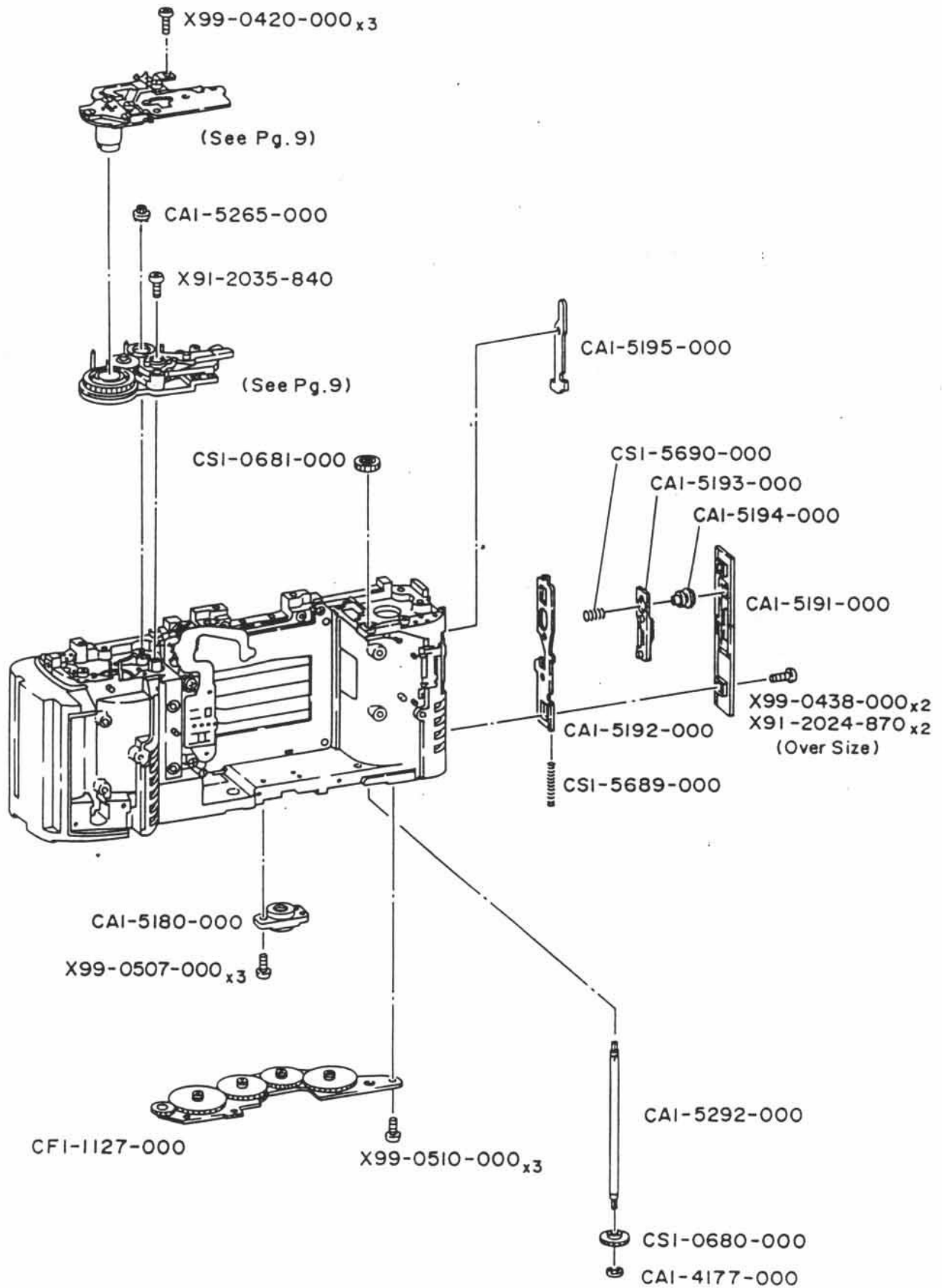

PARTS LIST

REWIND GEAR & LATCH MECHANISM

MARK	PART NO.	CLASS	QTY	DESCRIPTION
	CA1-4177-000	D	1	C RING
	CA1-5180-000	D	1	SCREW, TRIPOD
	CA1-5191-000	C	1	COVER, RIGHT FRONT
	CA1-5192-000	D	1	HOOK
	CA1-5193-000	C	1	KNOB, BACK COVER
	CA1-5194-000	D	1	BUTTON, LOCK
	CA1-5195-000	D	1	LEVER, LOCK
	CA1-5265-000	E	1	CLUTCH, SPOOL
	CA1-5292-000	E	1	SHAFT, REWIND
	CF1-1127-000	E	1	REWIND GEAR ASSY
	CS1-0680-000	E	1	GEAR
	CS1-0681-000	E	1	GEAR
	CS1-5689-000	D	1	SPRING, COIL
	CS1-5690-000	D	1	SPRING, COIL
	X91-2024-870		2	SCREW, CROSS-RECESS, PH
	X91-2035-840		1	SCREW, CROSS-RECESS, PH
	X99-0420-000		3	SCREW, CROSS-RECESS, PH
	X99-0438-000		2	SCREW, CROSS-RECESS, PH
	X99-0507-000		3	SCREW, CROSS-RECESS, PH
	X99-0510-000		3	SCREW, CROSS-RECESS, PH

9

CANON T70

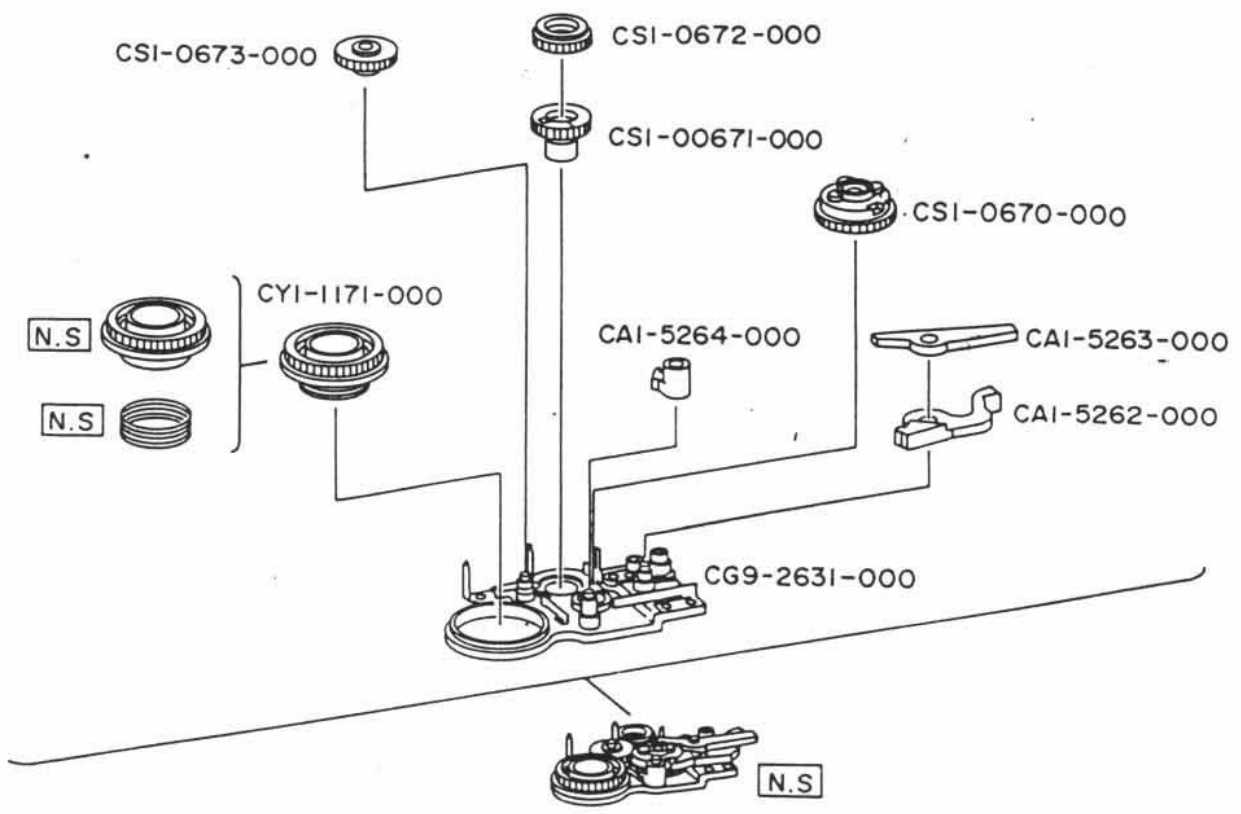
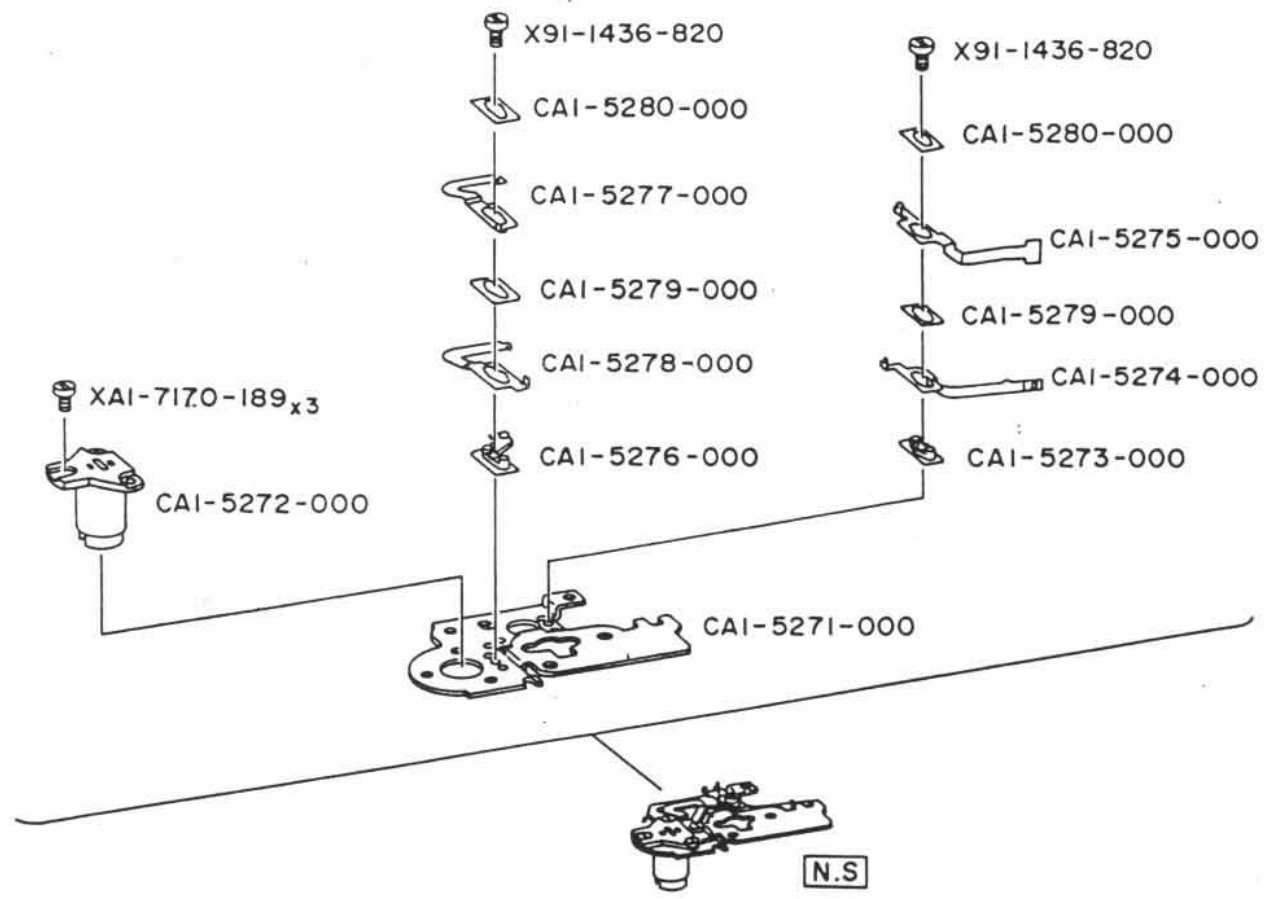

PARTS LIST

SWITCH & GEAR MECHANISM

MARK	PART NO.	CLASS	QTY	DESCRIPTION
	CA1-5262-000	E	1	LEVER, WINDING STOPPER
	CA1-5263-000	E	1	LEVER, MIRROR RETURNING
	CA1-5264-000	E	1	LEVER, RETURNING STOPPER
	CA1-5271-000	E	1	BASEPLATE, UPPER WINDING-2
	CA1-5272-000	E	1	HOLDER, MOTOR
	CA1-5273-000	D	1	BASE, CONTACT
	CA1-5274-000	D	1	CONTACT
	CA1-5275-000	D	1	CONTACT
	CA1-5276-000	D	1	BASE, CONTACT
	CA1-5277-000	D	1	CONTACT
	CA1-5278-000	D	1	CONTACT
	CA1-5279-000	E	2	INSULATOR
	CA1-5280-000	D	2	INSULATOR
	CG9-2631-000	E	1	BASEPLATE, UPPER WINDING-1
	CS1-0670-000	E	1	GEAR
	CS1-0671-000	E	1	GEAR
	CS1-0672-000	E	1	GEAR
	CS1-0673-000	E	1	GEAR
	CY1-1171-000	D	1	SPOOL GEAR ASSY
	XA1-7170-189		3	SCREW, CROSS-RECESS, PH
	X91-1436-820		2	SCREW, CROSS-RECESS, PH

CANON T70

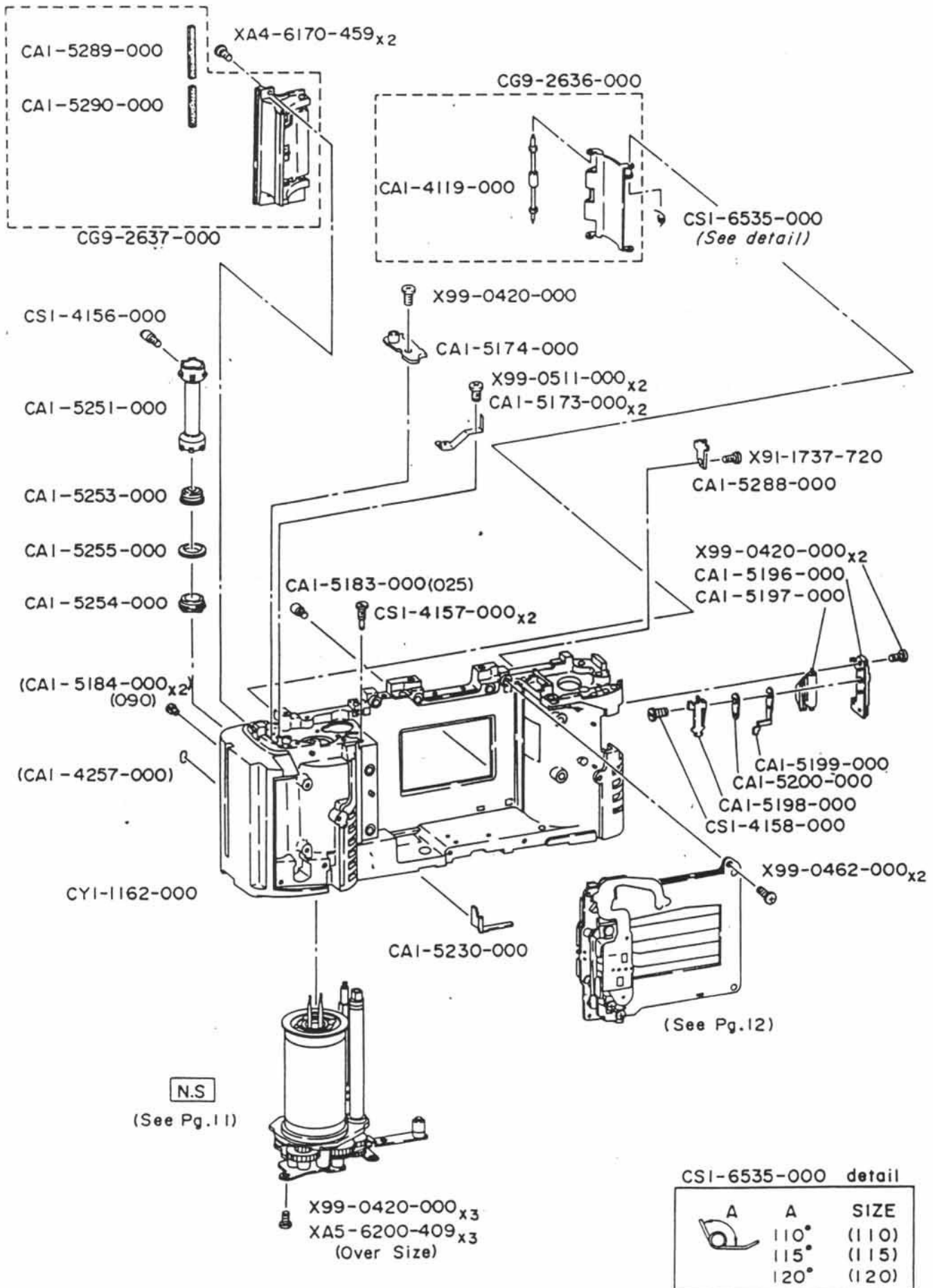

CSI-6535-000 detail

A	A	SIZE
	110°	(110)
	115°	(115)
	120°	(120)

PARTS LIST

SPROCKET PARTS & ROLLER HOLDER UNIT

MARK	PART NO.	CLASS	QTY	DESCRIPTION
	CA1-4119-000	E	1	ROLLER, AL
	CA1-4257-000	D	1	SEAL, FILM
	CA1-5173-000	C	2	CONTACT, BATTERY
	CA1-5174-000	E	1	COVER, BATTERY BOX
	CA1-5183-000(025)	E	1	SCREW
	CA1-5184-000(090)	E	2	CONTACT, DATA
	CA1-5196-000	E	1	BASE, CASSETTE SWITCH
	CA1-5197-000	E	1	LEVER, CASSETTE SWITCH
	CA1-5198-000	E	1	CONTACT
	CA1-5199-000	E	1	CONTACT
	CA1-5200-000	E	1	RETAINER
	CA1-5230-000	D	1	SHIELD, LIGHT
	CA1-5251-000	C	1	SPROCKET
	CA1-5253-000	E	1	COLOR, SPROCKET
	CA1-5254-000	E	1	RING, CAM
	CA1-5255-000	E	1	RING, RUBBER
	CA1-5288-000	E	1	HOLDER, CASSETTE
	CA1-5289-000	E	1	LIGHT, SHIELD
	CA1-5290-000	E	1	LIGHT, SHIELD
	CG9-2636-000	D	1	AL COVER UNIT
	CG9-2637-000	D	1	ROLLER HOLDER UNIT
	CS1-4156-000	D	1	SCREW
	CS1-4157-000	E	2	SCREW, SHAFT
	CS1-4158-000	E	1	SCREW
	CS1-6535-000	E	1	SPRING
	(ENTER SIZE WHEN ORDERING, SEE DETAIL)			
	CY1-1162-000	E	1	BODY
	XA4-6170-459		2	SCREW, CROSS-RECESS, PH
	XA5-6200-409		3	SCREW, CROSS-RECESS, PH
	X99-0420-000		6	SCREW, CROSS-RECESS, PH
	X99-0462-000		2	SCREW, CROSS-RECESS, PH
	X99-0511-000		2	SCREW, CROSS-RECESS, PH
	X91-1737-720		1	SCREW, CROSS-RECESS, PH

CANON T70

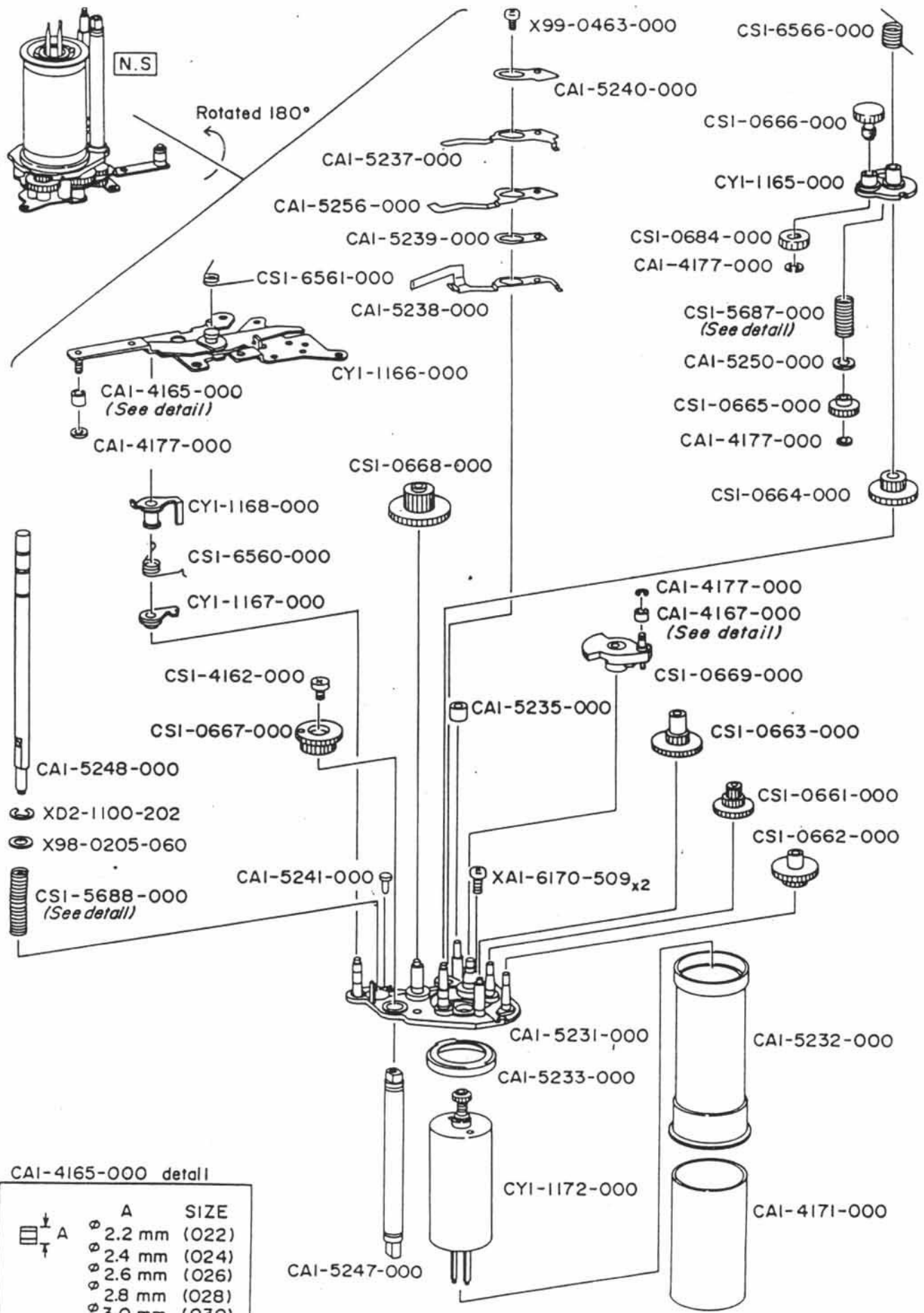

CAI-4165-000 detail

A	SIZE
∅ 2.2 mm (O22)	
∅ 2.4 mm (O24)	
∅ 2.6 mm (O26)	
∅ 2.8 mm (O28)	
∅ 3.0 mm (O30)	

PARTS LIST

MOTOR & GEAR MECHANISM

MARK	PART NO.	CLASS	QTY	DESCRIPTION
	CA1-4165-000 (ENTER SIZE WHEN ORDERING, SEE DETAIL)	E	1	COLLAR, CHARGE
	CA1-4167-000 (ENTER SIZE WHEN ORDERING, SEE DETAIL)	E	1	COLLAR, CHARGE
	CA1-4171-000	D	1	RUBBER, SPOOL
	CA1-4177-000	D	4	C RING
	CA1-5231-000	E	1	BASEPLATE, LOWER WINDING
	CA1-5232-000	E	1	SPOOL
	CA1-5233-000	E	1	SHAFT, SPOOL
	CA1-5235-000	E	1	RUBBER, STOPPER
	CA1-5237-000	E	1	CONTACT
	CA1-5238-000	E	1	CONTACT
	CA1-5239-000	E	1	INSULATOR
	CA1-5240-000	E	1	INSULATOR
	CA1-5241-000	E	1	PIN
	CA1-5247-000	E	1	SHAFT, WINDING
	CA1-5248-000	D	1	SHAFT, SPROCKET
	CA1-5250-000	E	1	WASHER
	CA1-5256-000	E	1	SPRING, PLATE
	CS1-0661-000	E	1	GEAR
	CS1-0662-000	E	1	GEAR
	CS1-0663-000	E	1	GEAR
	CS1-0664-000	E	1	GEAR
	CS1-0665-000	E	1	GEAR
	CS1-0666-000	E	1	GEAR
	CS1-0667-000	E	1	GEAR
	CS1-0668-000	E	1	GEAR
	CS1-0669-000	E	1	GEAR
	CS1-0684-000	E	1	GEAR
	CS1-4162-000	D	1	SCREW
	CS1-5687-000 (ENTER SIZE WHEN ORDERING, SEE DETAIL)	E	1	SPRING, COIL
	CS1-5688-000 (ENTER SIZE WHEN ORDERING, SEE DETAIL)	E	1	SPRING, COIL
	CS1-6560-000	E	1	SPRING
	CS1-6561-000	E	1	SPRING
	CS1-6566-000	E	1	SPRING
	CY1-1165-000	E	1	BASE, PLANETARY GEAR
	CY1-1166-000	E	1	BASEPLATE, LOWER WINDING-2
	CY1-1167-000	E	1	LEVER, LOCK
	CY1-1168-000	E	1	LEVER, CANCELLATION
	CY1-1172-000	D	1	MOTOR UNIT
	XA1-6170-509		2	SCREW, CROSS-RECESS, PH
	XD2-1100-202		1	E RING
	X98-0205-060		1	WASHER
	X99-0463-000		1	SCREW, CROSS-RECESS, PH

CA1-4167-000 detail

A	SIZE
 ϕ 2.8 mm (028)	
ϕ 3.0 mm (030)	
ϕ 3.1 mm (031)	
ϕ 3.2 mm (032)	
ϕ 3.3 mm (033)	
ϕ 3.4 mm (034)	
ϕ 3.5 mm (035)	
ϕ 3.6 mm (036)	
ϕ 3.7 mm (037)	

CS1-5687-000 detail

A	SIZE
 6.5 mm (150)	
7.7 mm (190)	

CS1-5688-000 detail

A	SIZE
 13.4 mm (200)	
14.9 mm (250)	
16.4 mm (300)	

CANON T70

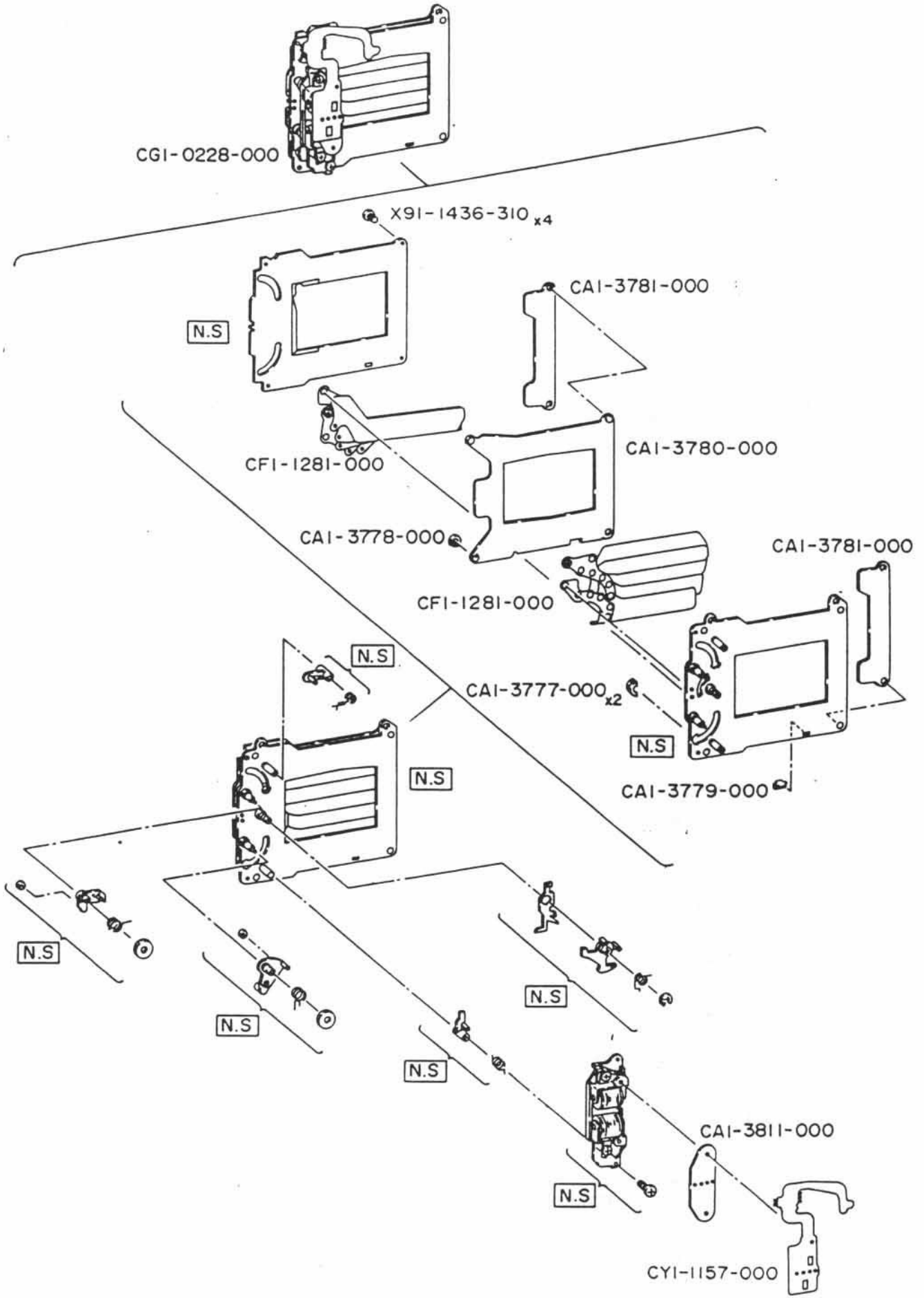

PARTS LIST

SHUTTER UNIT

MARK	PART NO.	CLASS	QTY	DESCRIPTION
	CA1-3777-000	E	1	RUBBER, STOPPER
	CA1-3778-000	E	1	RUBBER, STOPPER-A
	CA1-3779-000	E	1	RUBBER, STOPPER-B
	CA1-3780-000	E	1	PLATE, SEPARATOR
	CA1-3781-000	E	2	SPACE
	CA1-3811-000	E	1	PLATE, CONTACT POSITIONING
	CF1-1281-000	C	2	SHUTTER BLADE ASSY
	CG1-0228-000	C	1	SHUTTER UNIT
	CY1-1157-000	C	1	SHUTTER FLEX
	X91-1436-310		4	SCREW, CROSS-RECESS, PH

CANON T70

ELECTRIC PARTS UNIT
WIRING DIAGRAM

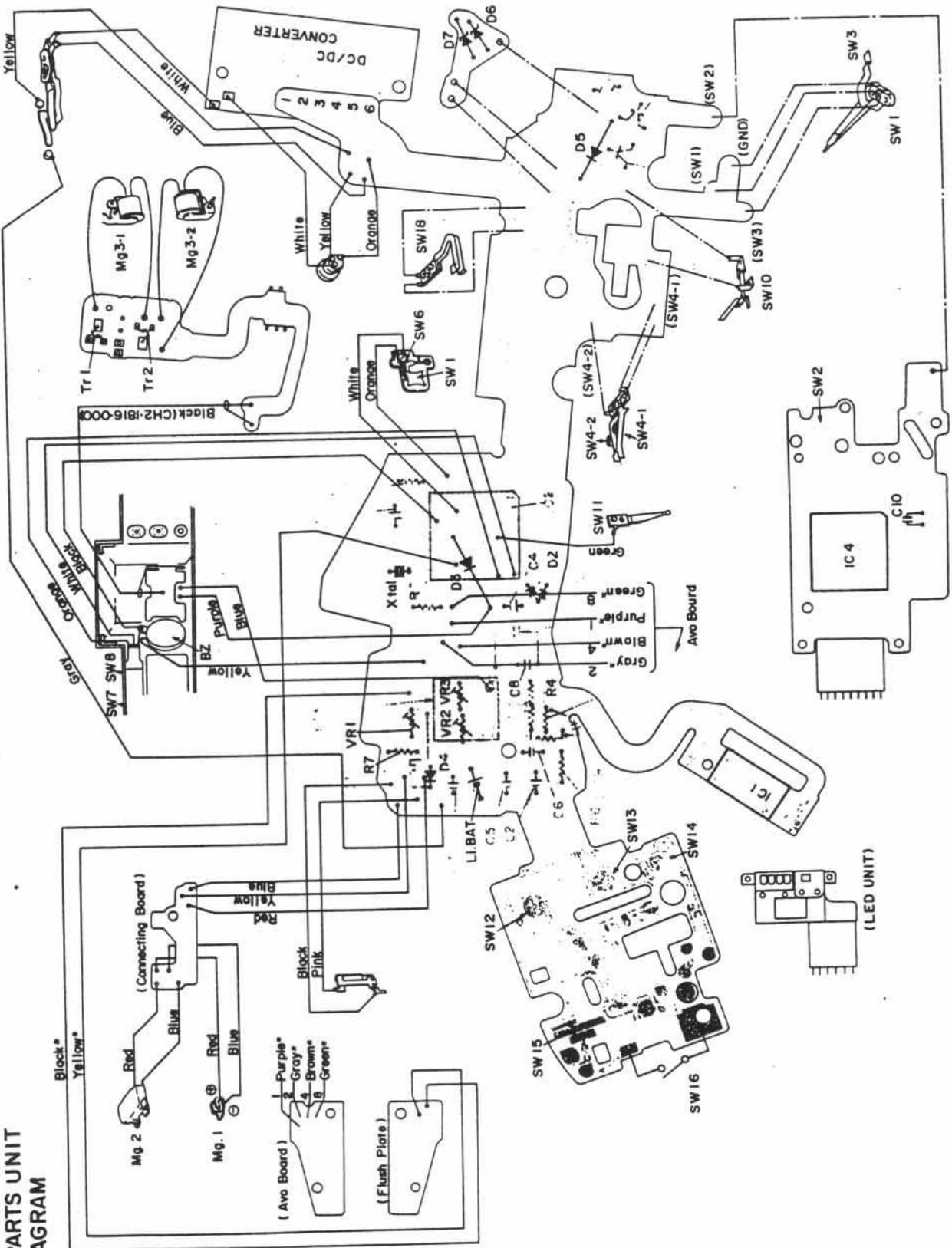

- Mg 2 (Connecting Board)
 - 1 Red
 - 2 Blue
 - 3 Yellow
 - 4 Blue
- Mg 1
 - 1 Red
 - 2 Blue
- (Avvo Board)
 - 1 Purple
 - 2 Gray
 - 3 Brown
 - 4 Green
- (Flush Plates)
 - 1 Black
 - 2 Pink

ELECTRIC PARTS SPECIFICATION LIST

SYMBOL	SPEC. OR MFG	SYMBOL	SPEC. OR MFG	
B.U BAT	CR1220	3V	SW1	LIGHT METER, SW
C1	4.7 uF	T	SW2	RELEASE, SW
C2	6.8 uF	T	SW3	RESET, SW
C3	0.22 uF	T	SW4-1	WINDING, SW
C4	0.1 uF	C	SW4-2	WINDING COMP, SW
C5	10 uF	T	SW5	EXPOSURE COMP, SW
C6	1 uF	T	SW6	TV LOCK, SW
C7	0.1 uF	C	SW7	SHIFT UP, SW
C8	0.1 uF	C	SW8	SHIFT DOWN, SW
C9	3300 PF	C	SW9	WINDING DISPLY, SW
C10	0.1 uF	C	SW10	REWINDING DISPLY, SW
C11	4.7 uF	T	SW11	A/M, SW
D1	1S2095A	VR1	SW12	MODE, SW
D2	MA151WA	VR2	SW13	ISO, SW
D3	1S2095A	VR3	SW14	BATTERY CHECK, SW
D4	1SS154		SW15	MODE SELECTOR, SW
D5	1S955		SW16	AL START, SW
D6	05Z6.8Z		SW17	CARTRING DISPLY, SW
			SW18	REWIND, SW
DC/DC				
IC-1	T2890			
IC-2	T6472			
IC-3	T1612			
IC-4	T6428			
R1	2 KOHM			
R2	2 KOHM			
R4	6.8 - 360 KOHM			
R5	3.32 - 3.92 KOHM			
R6	2 KOHM			
R7	12.1 - 40.2 KOHM			
R8	220 KOHM			
R9	4.3 - 470 KOHM			
Tr1	2SC2982			
Tr2	2SC2982			
Tr3	2SA1314			
Tr4	2SC2982			
VR1	10 KOHM			
VR2	12+40 KOHM			
VR3	20+145 KOHM			
XTa1	DT-261S			

CANON T-70

CONFIDENTIAL

REF. No. C12-1841

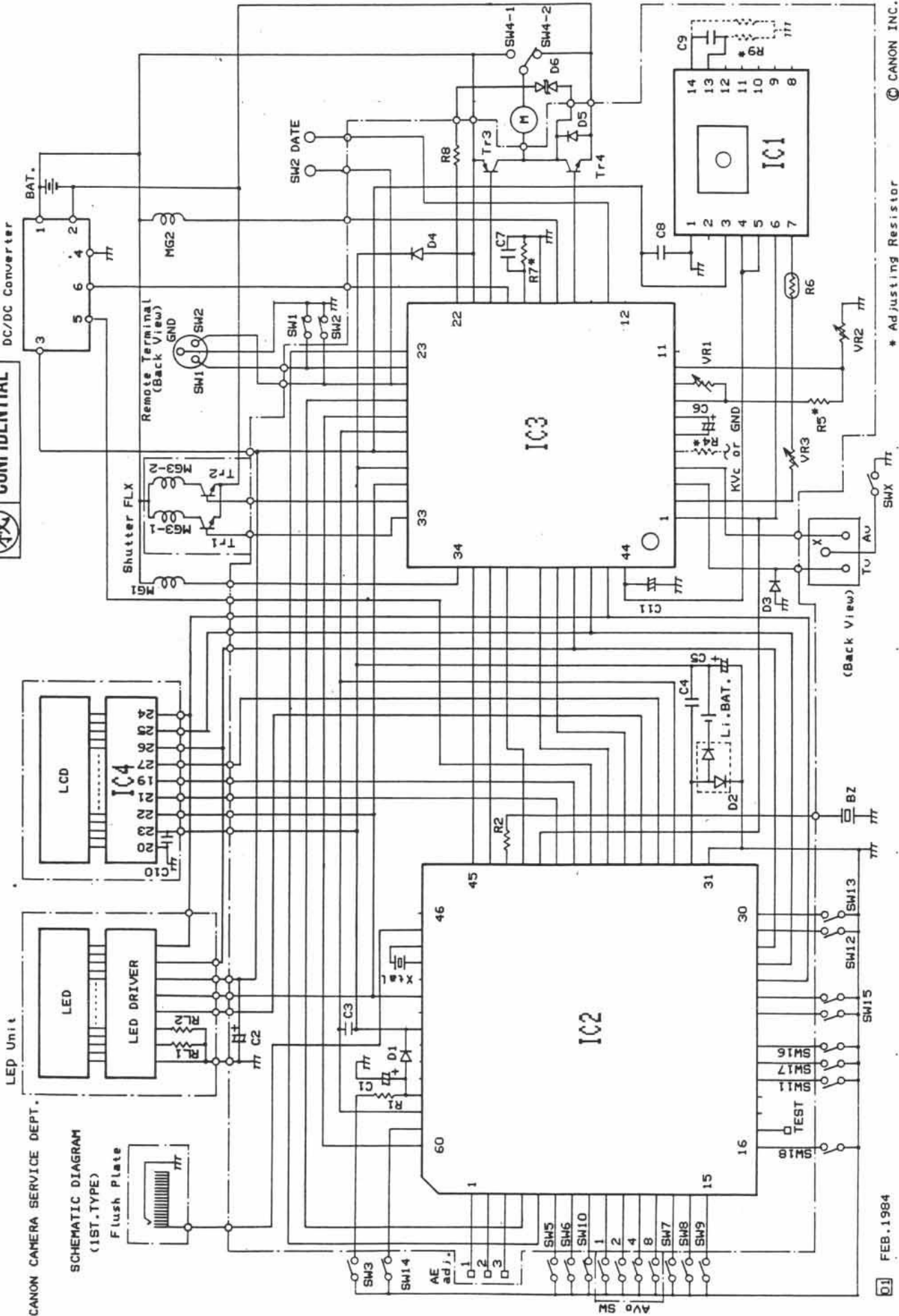

PARTS LIST

ELECTRIC PARTS & LEADS

SYMBOL	PART NO.	CLASS	DESCRIPTION	REMARKS
BU. BAT	WK1-9022-000	E	BATTERY, LITHIUM	CR1220
C1			CAPACITOR TANT	4.7uF 4.0V
C2			CAPACITOR TANT	6.8uF 6.3V
C3			CAPACITOR TANT	0.22uF 6.3V
C4			CAPACITOR CERA	0.1uF 2.5V
C5			CAPACITOR TANT	10uF 6.3V
C6			CAPACITOR TANT	1uF 16V
C7			CAPACITOR CERA	0.1uF 25V
C8			CAPACITOR CERA	0.1uF 25V
C9			CAPACITOR CERA	3300PF 25V
C10			CAPACITOR CERA	0.1uF 25V
C11			CAPACITOR TANT	4.7uF 3.15V
D1			DIODE	1S2095
D2			DIODE	MA151WA
D3			DIODE	1S2095
D4			DIODE	1SS154
D5			DIODE	1S955
D6			DIODE	05Z6.8Z
DC/DC	CH3-0016-000	D	CONVERTER, DC/DC	
IC-1	CH4-0112-000	C	IC	T2890
IC-2	CH4-0110-000	C	IC	T6472
IC-3	CH4-0111-000	C	IC	T1612
IC-4	CH4-0113-000	D	IC	T6428
R1			RESISTOR	2 KOHM 1/8W
R2			RESISTOR	2 KOHM 1/8W
R4	VR9-1087-000	E	RESISTOR	6.8 KOHM 1/8W
	VR9-1091-000	E	RESISTOR	10 KOHM 1/8W
	VR9-1664-000	E	RESISTOR	13 KOHM 1/8W
	VR9-1885-000	E	RESISTOR	16 KOHM 1/8W
	VR9-1886-000	E	RESISTOR	20 KOHM 1/8W
	VR9-1889-000	E	RESISTOR	30 KOHM 1/8W
	VR9-1892-000	E	RESISTOR	39 KOHM 1/8W
	VR9-1897-000	E	RESISTOR	68 KOHM 1/8W
	VR9-1412-000	E	RESISTOR	91 KOHM 1/8W
	VR9-2089-000	E	RESISTOR	130 KOHM 1/8W
	VR9-2099-000	E	RESISTOR	180 KOHM 1/8W
	VR9-2100-000	E	RESISTOR	270 KOHM 1/8W
	VR9-2101-000	E	RESISTOR	360 KOHM 1/8W
R5	VR9-1870-000	E	RESISTOR	3.32 KOHM 1/8W
	VR9-1871-000	E	RESISTOR	3.40 KOHM 1/8W
	VR9-1872-000	E	RESISTOR	3.48 KOHM 1/8W
	VR9-1873-000	E	RESISTOR	3.57 KOHM 1/8W
	VR9-1874-000	E	RESISTOR	3.65 KOHM 1/8W
	VR9-1875-000	E	RESISTOR	3.75 KOHM 1/8W
	VR9-1876-000	E	RESISTOR	3.83 KOHM 1/8W
	VR9-1877-000	E	RESISTOR	3.92 KOHM 1/8W
R6			RESISTOR	2 KOHM 1/8W
R7	VR9-2311-000	E	RESISTOR	12.1 KOHM 1/8W
	VR9-2312-000	E	RESISTOR	12.7 KOHM 1/8W
	VR9-2313-000	E	RESISTOR	13.1 KOHM 1/8W
	VR9-2314-000	E	RESISTOR	14.0 KOHM 1/8W
	VR9-2315-000	E	RESISTOR	14.7 KOHM 1/8W
	VR9-3047-000	E	RESISTOR	15.4 KOHM 1/8W
	VR9-3048-000	E	RESISTOR	16.2 KOHM 1/8W
	VR9-3051-000	E	RESISTOR	17.8 KOHM 1/8W
	VR9-3052-000	E	RESISTOR	20.5 KOHM 1/8W

PARTS LIST

ELECTRIC PARTS & LEADS

SYMBOL	PART NO.	CLASS	DESCRIPTION	REMARKS
	VR9-3053-000	E	RESISTOR	21.5 KOHM 1/8W
	VR9-3054-000	E	RESISTOR	22.6 KOHM 1/8W
	VR9-3055-000	E	RESISTOR	23.7 KOHM 1/8W
	VR9-3056-000	E	RESISTOR	27.4 KOHM 1/8W
	VR9-3057-000	E	RESISTOR	30.1 KOHM 1/8W
	VR9-3058-000	E	RESISTOR	33.2 KOHM 1/8W
	VR9-3059-000	E	RESISTOR	36.5 KOHM 1/8W
	VR9-3060-000	E	RESISTOR	38.3 KOHM 1/8W
	VR9-3061-000	E	RESISTOR	40.2 KOHM 1/8W
R8			RESISTOR	220. KOHM 1/8W
R9	VR9-1082-000	E	RESISTOR	4.3 KOHM 1/8W
	VR9-1083-000	E	RESISTOR	4.7 KOHM 1/8W
	VR9-1084-000	E	RESISTOR	5.1 KOHM 1/8W
	VR9-1085-000	E	RESISTOR	5.6 KOHM 1/8W
	VR9-1086-000	E	RESISTOR	6.2 KOHM 1/8W
	VR9-1087-000	E	RESISTOR	6.8 KOHM 1/8W
	VR9-1088-000	E	RESISTOR	7.5 KOHM 1/8W
	VR9-1089-000	E	RESISTOR	8.2 KOHM 1/8W
	VR9-1090-000	E	RESISTOR	9.1 KOHM 1/8W
	VR9-1091-000	E	RESISTOR	10 KOHM 1/8W
	VR9-1092-000	E	RESISTOR	11 KOHM 1/8W
	VR9-1093-000	E	RESISTOR	12 KOHM 1/8W
	VR9-1095-000	E	RESISTOR	15 KOHM 1/8W
	VR9-1097-000	E	RESISTOR	18 KOHM 1/8W
	VR9-1099-000	E	RESISTOR	22 KOHM 1/8W
	VR9-1103-000	E	RESISTOR	33 KOHM 1/8W
	VR9-1109-000	E	RESISTOR	56 KOHM 1/8W
	VR9-1115-000	E	RESISTOR	100 KOHM 1/8W
Tr1			TRANSISTOR	2SC 2982
Tr2				2SC 2982
Tr3	WA2-0411-000	E	TRANSISTOR	2SA 1314
Tr4	WA2-0216-000	E	TRANSISTOR	2SC 2982
VR1	CH9-0074-000	E	RESISTOR, VARIABLE	10 KOHM
VR2	CH9-0075-000	E	RESISTOR, VARIABLE	12+40 KOHM
VR3	CH9-0076-000	E	RESISTOR, VARIABLE	20+145 KOHM
X'TAL				DT-261S
	CH2-1816-000		LEAD, SHIELDID	(BLACK)
	Y11-3901-000			LEAD (WHITE)
	Y11-3902-000			LEAD (BLACK)
	Y11-3904-000			LEAD (PINK)
	Y11-3906-000			LEAD (ORANGE)
	Y11-3907-000			LEAD (YELLOW)
	Y11-3911-000			LEAD (BLUE)
	Y11-3912-000			LEAD (PURPLE)
	Y11-4502-000			LEAD (BLACK)
	Y11-4507-000			LEAD (YELLOW)
	Y11-4509-000			LEAD (GREEN)
	Y11-4512-000			LEAD (PURPLE)
	Y11-4513-000			LEAD (BLOWN)
	Y11-4514-000			LEAD (GRAY)

INDEX OF PARTS NUMBERS

NEW	PART NO.	PAGE	ADDRESS	NEW	PART NO	PAGE	ADDRESS
	10-0233-000	5	B-1,2	*	CA1-5218-000	3	A-11,12
	CA1-1113-000	6	B-3,4	*	CA1-5219-000	3	A-11,12
	CA1-1113-000(001)	6	B-3,4	*	CA1-5220-000	5	B-1,2
	CA1-1147-010	6	B-3,4	*	CA1-5221-000	4	A-13,14
	CA1-1374-000	2	A-9,10	*	CA1-5222-000	4	A-13,14
	CA1-1525-000	6	B-3,4	*	CA1-5223-000	4	A-13,14
	CA1-3385-000	2	A-9,10	*	CA1-5226-000	4	A-13,14
	CA1-3777-000	12	C-1,2	*	CA1-5227-000	4	A-13,14
	CA1-3778-000	12	C-1,2	*	CA1-5228-000	3	A-11,12
	CA1-3779-000	12	C-1,2	*	CA1-5230-000	10	B-11,12
	CA1-3780-000	12	C-1,2	*	CA1-5231-000	11	B-13,14
	CA1-3781-000	12	C-1,2	*	CA1-5232-000	11	B-13,14
	CA1-3811-000	12	C-1,2	*	CA1-5233-000	11	B-13,14
	CA1-4108-000	1	A-7,8	*	CA1-5235-000	11	B-13,14
	CA1-4119-000	10	B-11,12	*	CA1-5237-000	11	B-13,14
	CA1-4156-000	3	A-11,12	*	CA1-5238-000	11	B-13,14
	CA1-4158-000	3	A-11,12	*	CA1-5239-000	11	B-13,14
	CA1-4165-000	11	B-13,14	*	CA1-5240-000	11	B-13,14
*	CA1-4167-000	11	B-13,14	*	CA1-5241-000	11	B-13,14
	CA1-4171-000	11	B-13,14	*	CA1-5247-000	11	B-13,14
	CA1-4177-000	8	B-7,8	*	CA1-5248-000	11	B-13,14
		11	B-13,14	*	CA1-5250-000	11	B-13,14
	CA1-4238-000	2	A-9,10	*	CA1-5251-000	10	B-11,12
	CA1-4257-000	10	B-11,12	*	CA1-5253-000	10	B-11,12
	CA1-4275-000	6	B-3,4	*	CA1-5254-000	10	B-11,12
	CA1-4277-000	6	B-3,4	*	CA1-5255-000	10	B-11,12
	CA1-4848-000	5	B-1,2	*	CA1-5256-000	11	B-13,14
	CA1-4930-000	6	B-3,4	*	CA1-5262-000	9	B-9,10
	CA1-5074-000	3	A-11,12	*	CA1-5263-000	9	B-9,10
	CA1-5129-010	6	B-3,4	*	CA1-5264-000	9	B-9,10
	CA1-5133-000	5	B-1,2	*	CA1-5265-000	8	B-7,8
*	CA1-5171-000	1	A-7,8	*	CA1-5271-000	9	B-9,10
*	CA1-5172-000	4	A-13,14	*	CA1-5272-000	9	B-9,10
*	CA1-5173-000	10	B-11,12	*	CA1-5273-000	9	B-9,10
*	CA1-5174-000	10	B-11,12	*	CA1-5274-000	9	B-9,10
*	CA1-5175-000	4	A-13,14	*	CA1-5275-000	9	B-9,10
*	CA1-5176-000	3	A-11,12	*	CA1-5276-000	9	B-9,10
*	CA1-5177-000	3	A-11,12	*	CA1-5277-000	9	B-9,10
*	CA1-5178-000	5	B-1,2	*	CA1-5278-000	9	B-9,10
*	CA1-5179-000	5	B-1,2	*	CA1-5279-000	9	B-9,10
*	CA1-5182-000	3	A-11,12	*	CA1-5280-000	9	B-9,10
*	CA1-5183-000(025)	10	B-11,12	*	CA1-5283-000	3	A-11,12
*	CA1-5184-000(090)	10	B-11,12	*	CA1-5284-000	4	A-13,14
*	CA1-5189-000	4	A-13,14	*	CA1-5288-000	10	B-11,12
*	CA1-5180-000	8	B-7,8	*	CA1-5289-000	10	B-11,12
*	CA1-5191-000	8	B-7,8	*	CA1-5290-000	10	B-11,12
*	CA1-5192-000	8	B-7,8	*	CA1-5292-000	8	B-7,8
*	CA1-5193-000	8	B-7,8	*	CA1-5295-000	1	A-7,8
*	CA1-5194-000	8	B-7,8	*	CA1-5298-000	1	A-7,8
*	CA1-5195-000	8	B-7,8	*	CA1-5304-000	2	A-9,10
*	CA1-5196-000	10	B-11,12	*	CA1-5305-000	2	A-9,10
*	CA1-5197-000	10	B-11,12	*	CA1-5306-000	2	A-9,10
*	CA1-5198-000	10	B-11,12	*	CA1-5311-000	2	A-9,10
*	CA1-5199-000	10	B-11,12	*	CA1-5312-000	2	A-9,10
*	CA1-5200-000	10	B-11,12	*	CA1-5313-000	2	A-9,10
*	CA1-5201-000	3	A-11,12	*	CA1-5314-000	2	A-9,10
*	CA1-5202-000	3	A-11,12	*	CA1-5315-000	2	A-9,10
*	CA1-5203-000	3	A-11,12	*	CA1-5316-000	2	A-9,10
*	CA1-5204-000	3	A-11,12	*	CA1-5318-000	2	A-9,10
*	CA1-5205-000	3	A-11,12	*	CA1-5322-000	3	A-11,12
*	CA1-5206-000	3	A-11,12	*	CA1-5325-000	3	A-11,12
*	CA1-5209-000	3	A-11,12	*	CA1-5331-000	5	B-1,2
*	CA1-5210-000	3	A-11,12	*	CA1-5332-000	5	B-1,2
*	CA1-5212-000	4	A-13,14	*	CA1-5333-000	5	B-1,2
*	CA1-5214-000	1	A-7,8	*	CA1-5334-000	5	B-1,2
*	CA1-5215-000	1	A-7,8	*	CA1-5336-000	5	B-1,2
*	CA1-5216-000	4	A-13,14	*	CA1-5337-000	5	B-1,2
*	CA1-5217-000	4	A-13,14	*	CA1-5349-000	6	B-3,4
				*	CA1-5354-000	6	B-3,4

INDEX OF PARTS NUMBERS

NEW	PART NO.	PAGE	ADDRESS	NEW	PART NO	PAGE	ADDRESS
*	CA1-5355-000	6	B-3,4	*	CS1-0673-000	9	B-9,10
*	CA1-5356-000	6	B-3,4	*	CS1-0680-000	8	B-7,8
*	CA1-5375-000	7	B-5,6	*	CS1-0681-000	8	B-7,8
	CA4-1847-000	1	A-7,8	*	CS1-0682-000	4	A-13,14
	CF1-0423-000	3	A-11,12	*	CS1-0683-000	4	A-13,14
*	CF1-1127-000	8	B-7,8	*	CS1-0684-000	11	B-13,14
*	CF1-1136-000	6	B-3,4	*	CS1-4156-000	10	B-11,12
*	CF1-1139-000	7	B-5,6	*	CS1-4157-000	10	B-11,12
*	CF1-1146-000	1	A-7,8	*	CS1-4158-000	10	B-11,12
*	CF1-1148-000	5	B-1,2	*	CS1-4159-000	5	B-1,2
*	CF1-1278-000	2	A-9,10	*	CS1-4160-000	3	A-11,12
*	CF1-1279-000	4	A-13,14	*	CS1-4161-000	5	B-1,2
	CF1-1281-000	12	C-1,2	*	CS1-4162-000	11	B-13,14
*	CG1-0218-000	2	A-9,10		CS1-5638-000	7	B-5,6
*	CG1-0219-000	3	A-11,12		CS1-5640-000	7	B-5,6
*	CG1-0222-000	4	A-13,14		CS1-5642-000	7	B-5,6
*	CG1-0225-000	7	B-5,6		CS1-5643-000	7	B-5,6
*	CG1-0226-000	7	B-5,6		CS1-5644-000	7	B-5,6
*	CG1-0227-000	7	B-5,6	*	CS1-5646-000	7	B-5,6
*	CG1-0228-000	12	C-1,2	*	CS1-5648-000	7	B-5,6
*	CG9-2631-000	9	B-9,10	*	CS1-5649-000	7	B-5,6
*	CG9-2634-000	4	A-13,14		CS1-5650-000	7	B-5,6
*	CG9-2635-000	1	A-7,8		CS1-5651-000	7	B-5,6
*	CG9-2636-000	10	B-11,12		CS1-5652-000	7	B-5,6
*	CG9-2637-000	10	B-11,12		CS1-5653-000	7	B-5,6
*	CG9-2639-000	4	A-13,14	*	CS1-5687-000	11	B-13,14
*	CG9-2645-000	4	A-13,14	*	CS1-5688-000	11	B-13,14
*	CH1-0403-000	6	B-3,4	*	CS1-5689-000	8	B-7,8
*	CH1-0407-000	6	B-3,4	*	CS1-5690-000	8	B-7,8
*	CH2-1805-000	3	A-11,12	*	CS1-5691-000	4	A-13,14
*	CH2-1806-000	3	A-11,12	*	CS1-5692-000	5	B-1,2
	CH2-1816-000	15	C-6	*	CS1-5694-000	7	B-5,6
*	CH2-1823-000	5	B-1,2	*	CS1-5695-000	7	B-5,6
*	CH3-0016-000	4	A-13,14	*	CS1-5696-000	3	A-11,12
		14	C-5	*	CS1-5700-000	7	B-5,6
	CH4-0110-000	14	C-5	*	CS1-5701-000	7	B-5,6
	CH4-0111-000	14	C-5	*	CS1-6535-000	10	B-11,12
	CH4-0112-000	14	C-5	*	CS1-6560-000	11	B-13,14
	CH4-0113-000	14	C-5	*	CS1-6561-000	11	B-13,14
*	CH4-0114-000	5	B-1,2	*	CS1-6566-000	11	B-13,14
	CH9-0074-000	15	C-6		CS2-6109-000	5	B-1,2
	CH9-0075-000	15	C-6	*	CY1-1157-000	12	C-1,2
	CH9-0076-000	15	C-6	*	CY1-1161-000	3	A-11,12
	CN1-5001-000	6	B-3,4	*	CY1-1162-000	10	B-11,12
*	CN1-5261-000	5	B-1,2	*	CY1-1163-000	4	A-13,14
*	CN1-5262-000	5	B-1,2	*	CY1-1164-000	1	A-7,8
*	CS1-0661-000	11	B-13,14	*	CY1-1165-000	11	B-13,14
*	CS1-0662-000	11	B-13,14	*	CY1-1166-000	11	B-13,14
*	CS1-0663-000	11	B-13,14	*	CY1-1167-000	11	B-13,14
*	CS1-0664-000	11	B-13,14	*	CY1-1168-000	11	B-13,14
*	CS1-0665-000	11	B-13,14	*	CY1-1169-000	3	A-11,12
*	CS1-0666-000	11	B-13,14	*	CY1-1170-000	6	B-3,4
*	CS1-0667-000	11	B-13,14	*	CY1-1171-000	9	B-9,10
*	CS1-0668-000	11	B-13,14	*	CY1-1172-000	11	B-13,14
*	CS1-0669-000	11	B-13,14		VR9-1082-000	15	C-6
*	CS1-0670-000	9	B-9,10		VR9-1083-000	15	C-6
*	CS1-0671-000	9	B-9,10		VR9-1084-000	15	C-6
*	CS1-0672-000	9	B-9,10		VR9-1085-000	15	C-6
					VR9-1086-000	15	C-6
					VR9-1087-000	14	C-5
						15	C-6
					VR9-1088-000	15	C-6
					VR9-1089-000	15	C-6
					VR9-1090-000	15	C-6
					VR9-1091-000	14	C-5
					VR9-1091-000	15	C-6

INDEX OF PARTS NUMBERS

NEW	PART NO.	PAGE	ADDRESS	NEW	PART NO	PAGE	ADDRESS
	VR9-1092-000	15	C-6	*	XA4-6170-459	10	B-11,12
	VR9-1093-000	15	C-6	*	XA4-6170-507	4	A-13,14
	VR9-1095-000	15	C-6				
	VR9-1097-000	15	C-6		XA5-6200-409	10	B-11,12
	VR9-1099-000	15	C-6				
	VR9-1103-000	15	C-6		XD1-1101-811	6	B-3,4
	VR9-1109-000	15	C-6		XD1-1102-120	6	B-3,4
	VR9-1115-000	15	C-6		XD1-1102-121	6	B-3,4
	VR9-1412-000	14	C-5				
	VR9-1664-000	14	C-5		XD2-1100-072	6	B-3,4
	VR9-1870-000	14	C-5		XD2-1100-102	1	A-7,8
	VR9-1871-000	14	C-5		XD2-1100-102	2	A-9,10
	VR9-1872-000	14	C-5		XD2-1100-202	11	B-13,14
	VR9-1873-000	14	C-5		XD2-1200-152	2	A-9,10
	VR9-1874-000	14	C-5				
	VR9-1875-000	14	C-5		X71-9749-000	7	B-5,6
	VR9-1876-000	14	C-5		X71-9750-000	7	B-5,6
	VR9-1877-000	14	C-5				
*	VR9-1885-000	14	C-5		X91-1436-310	12	C-1,2
	VR9-1886-000	14	C-5	*	X91-1436-820	9	B-9,10
	VR9-1889-000	14	C-5		X91-1737-130	4	A-13,14
	VR9-1892-000	14	C-5		X91-1737-380	1	A-7,8
	VR9-1897-000	14	C-5		X91-1737-390	1	A-7,8
*	VR9-2089-000	14	C-5	*	X91-1737-450	1	A-7,8
	VR9-2099-000	14	C-5	*	X91-1737-720	10	B-11,12
	VR9-2100-000	14	C-5		X91-2024-870	8	B-7,8
	VR9-2101-000	14	C-5		X91-2035-840	8	B-7,8
*	VR9-2311-000	14	C-5				
*	VR9-2312-000	14	C-5		X98-0202-060	6	B-3,4
*	VR9-2313-000	14	C-5	*	X98-0205-060	11	B-13,14
*	VR9-2314-000	14	C-5				
*	VR9-2315-000	14	C-5		X99-0295-000	5	B-1,2
*	VR9-3047-000	14	C-5		X99-0420-000	3	A-11,12
*	VR9-3048-000	14	C-5			4	A-13,14
*	VR9-3051-000	14	C-5			8	B-7,8
*	VR9-3052-000	14	C-5			10	B-11,12
*	VR9-3053-000	15	C-6		X99-0422-000	3	A-11,12
*	VR9-3054-000	15	C-6		X99-0438-000	8	B-7,8
*	VR9-3055-000	15	C-6		X99-0454-000	5	B-1,2
*	VR9-3056-000	15	C-6		X99-0462-000	4	A-13,14
*	VR9-3057-000	15	C-6			10	B-11,12
*	VR9-3058-000	15	C-6	*	X99-0463-000	11	B-13,14
*	VR9-3059-000	15	C-6		X99-0465-000	5	B-1,2
*	VR9-3060-000	15	C-6	*	X99-0467-000	1	A-7,8
*	VR9-3061-000	15	C-6	*	X99-0481-000	3	A-11,12
				*	X99-0482-000	1	A-7,8
	WA2-0216-000	15	C-6	*	X99-0505-000	1	A-7,8
*	WA2-0411-000	15	C-6	*	X99-0506-000	4	A-13,14
				*	X99-0507-000	8	B-7,8
*	WG2-9083-000	3	A-11,12	*	X99-0510-000	8	B-7,8
				*	X99-0511-000	10	B-11,12
*	WK1-9022-000	14	C-5	*	X99-0512-000	4	A-13,14
				*	X99-0513-000	3	A-11,12
	XA1-1170-169	6	B-3,4				
	XA1-1170-189	6	B-3,4				
	XA1-1170-209	6	B-3,4		Y11-3901-000	15	C-6
	XA1-1200-809	5	B-1,2		Y11-3902-000	15	C-6
*	XA1-1200-909	5	B-1,2		Y11-3904-000	15	C-6
	XA1-3170-159	6	B-3,4		Y11-3906-000	15	C-6
	XA1-3170-509	2	A-9,10		Y11-3907-000	15	C-6
	XA1-3200-409	6	B-3,4		Y11-3911-000	15	C-6
	XA1-6170-359	7	B-5,6		Y11-3912-000	15	C-6
	XA1-6170-509	11	B-13,14		Y11-4502-000	15	C-6
*	XA1-7140-287	3	A-11,12		Y11-4507-000	15	C-6
	XA1-7170-189	9	B-9,10		Y11-4509-000	15	C-6
*	XA1-7170-207	6	B-3,4		Y11-4512-000	15	C-6
	XA1-7170-259	6	B-3,4		Y11-4513-000	15	C-6
	XA1-7170-359	5	B-1,2		Y11-4514-000	15	C-6

CANON CASE FOR T70

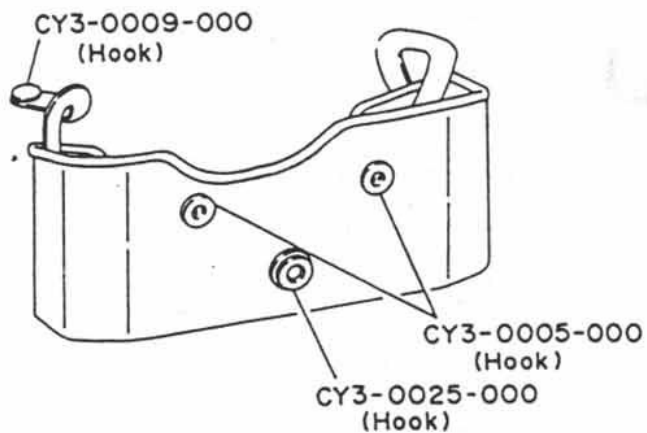
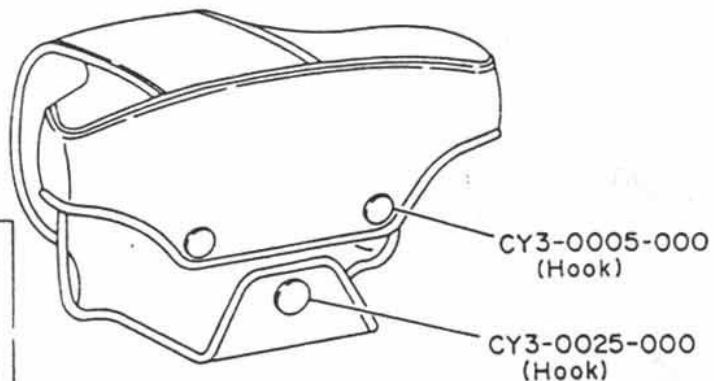
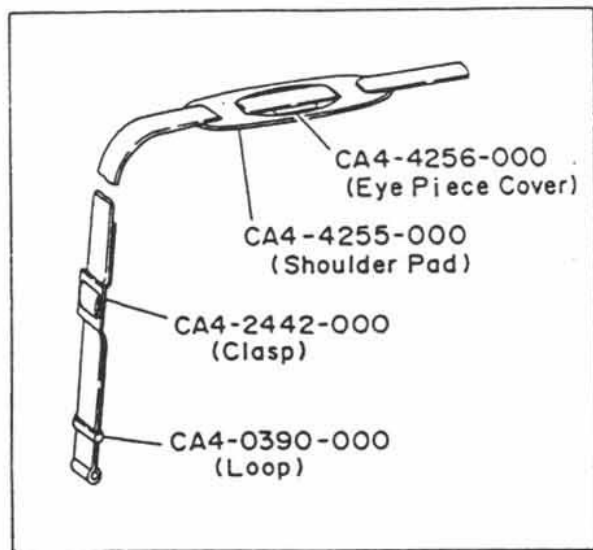

PARTS LIST

NEW	PART NO.	CLASS	QTY	DESCRIPTION
	CA4-0390-000	D	1	LOOP
	CA4-2442-000	E	1	CLASP
*	CA4-4255-000	E	1	PAD, SHOULDER
*	CA4-4256-000	D	1	COVER, EYEPIECE.
	CY3-0005-000	D	1	HOOK
	CY3-0009-000	E	1	HOOK
	CY3-0025-000	D	1	HOOK